

PORTABLE REFRIGERATED AIR CONDITIONER

# USER MANUAL

For

# POLOCOOL

KN 10C – 10,000 BTU (2.9kW)

KN 12C – 12,000 BTU (3.5kW)

KN 14C – 14,000 BTU (4.1kW)

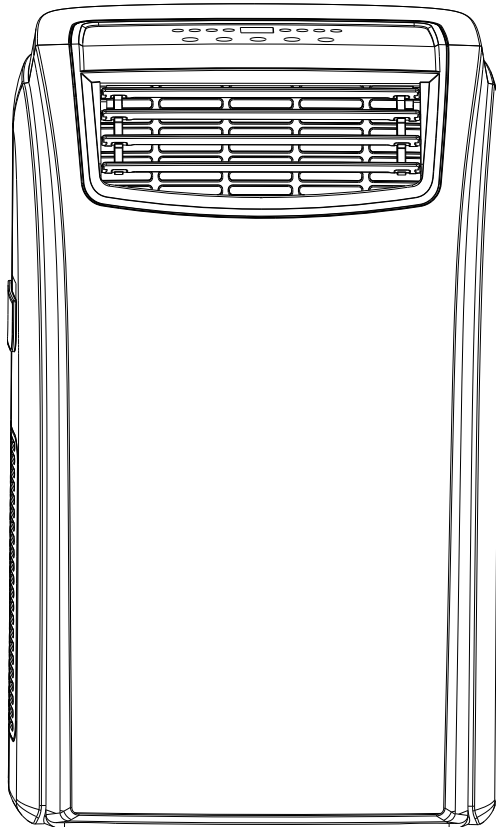

Thank you for selecting our quality air conditioner. Please be sure to read this user manual carefully before using. POLOCOOL portable refrigerated air conditioners are imported and distributed throughout Australasia by POLO Appliances.

Any enquiries should be directed to Polo on 1 800 087 840 in the first instance.

**POLO Appliances** ABN 80 749 103 558

17 Brett Drive, Carrum Downs, VIC 3201

[www.polocool.com.au](http://www.polocool.com.au)

[www.mypolo.com.au](http://www.mypolo.com.au)

# **Important Issues Regarding the Proper Use of this Air Conditioner**

**Please contact Polo on 1 800 087 840  
for advice before returning unit**

Use this air conditioner only as described in this instruction manual.

- This appliance is fitted with a special safety device. When the compressor switches off or when the appliance is first turned on, this device prevents the compressor from switching on again for at least three minutes.
- This air conditioner has been designed and manufactured to operate in a domestic situation only and should not be used for other purposes.
- The appliance is not intended for use by persons (including children) with reduced physical, sensory or mental capabilities, or lack of experience and knowledge, unless they have been given supervision or instruction concerning use of the appliance by a person responsible for their safety. Children should be supervised to ensure they don't play with the appliance.
- Never use the air conditioner in damp rooms (eg bathrooms and laundries).
- If the power cord is damaged, it must be replaced with a new cord installed by a suitably qualified person or POLO serviceman.
- This air conditioner is designed to be connected to a standard 10 amp power supply outlet.
- Do not pull on or place strain on the power cord when using the appliance.
- Do not operate or stop the appliance by inserting or pulling out the power plug. Use the on/off switch on the air conditioner control panel or the remote control.
- Do not connect to multiple power outlets on extension leads.
- Do not rest hot or heavy objects on the appliance.
- Always unplug the unit from the power outlet before cleaning or maintenance operations, for example filter cleaning.
- Do not place the air conditioner or plastic window slider in direct sunlight.
- For maximum cooling efficiency keep the exhaust hose as short and as free of bends as possible.
- Clean the filters at least once every two weeks.
- Do not splash the unit with water.
- Do not move the unit by pulling the exhaust hose attached to the back of the unit.
- Do not move air conditioner when it is operating.
- Do not use the unit with the air intake and outlet grills closed, covered or obstructed.
- Before transporting drain the water tray in accordance with the instructions on page 15. After transportation, wait at least one hour before switching the unit on.
- The unit should be transported in a vertical position. If this is not possible, secure the unit at an angle, do not lay it horizontally. After transporting, wait at least one hour before switching the unit on.
- Do not operate the air conditioner outdoors or in areas open to the outdoors.
- If the air conditioner is correctly set and runs without cool air coming out of the top air outlet after 10 minutes of correct operation, switch off the unit and contact POLO immediately.
- When cool air is coming out of the front air outlet, hot air should always be expelled from the bottom rear outlet. If it is not, switch off and contact POLO immediately.

**THIS PRODUCT IS FOR HOUSEHOLD USE ONLY  
RETAIN THIS MANUAL FOR FUTURE REFERENCE**

# CONTENTS

Introduction.....	3
Installation .....	5
Control panel .....	8
Operation.....	9
Description of remote control.....	10
Water drainage methods .....	14
Maintenance and service.....	15
Trouble shooting.....	16
Specifications .....	17

## **INTRODUCTION**

This portable air conditioner can alter the room temperature and humidity. It has multiple functions of cooling dehumidifying (drying) and fan ventilation, and can be moved from room to room and transported from building to building easily.

The air conditioner can maintain set room indoor air temperatures between 18°C and 32°C. The set room temperature is displayed on the remote control and in the control panel on the unit. This does not mean that the air conditioner will necessarily reduce the actual room temperature to the set room temperature.

The Polocool KN 10 C portable refrigerated air conditioner has a maximum cooling capacity of 10,000 BTU or 2.9kW. It is suitable to cool rooms up to 19 square metres of floor area in ideal conditions. The Polocool KN 12C has a maximum cooling capacity of 12,000 BTU or 3.5kW. It is suitable to cool rooms up to 23 square metres of floor area in ideal conditions. The Polocool KN 14C has a maximum cooling capacity of 14,000 BTU or 4.1kW. It is suitable to cool rooms up to 27 square metres of floor area in ideal conditions.

This air conditioner incorporates the latest mist motor technology which means the water tray will never need emptying, even in extremely humid conditions.

In dehumidifying mode the mist motor does not operate and the drain hose can be connected to drain excess water and ensure the water tray only needs occasional emptying.

## **GUIDELINES FOR OPTIMISING COOLING EFFECTIVENESS**

- Do not place the air conditioner or plastic window slider in direct sunlight. Close all curtains in the room being cooled.
- For maximum cooling press the POWERFUL button on the remote control (see page 10) – the appliance operates in cool mode at maximum fan speed. While this function is selected it is not possible to set the temperature or change fan speed.
- After approximately three minutes of operation the compressor will turn on and cooled air will come out of the front air outlet. Hot air will also come out of the exhaust hose
- In COOLING MODE the air conditioner will not cool unless the set temperature is below the existing room temperature
- In COOLING MODE once the existing room temperature reaches the set temperature , the fan continues operating and the compressor switches on and off to maintain the set temperature within the room.
- For maximum cooling output keep the exhaust hose as straight as possible. Minimise bends which can reduce the maximum cooling capacity of the air conditioner.
- Make sure the air intake and outlet grills are unobstructed.
- Clean the filters at least once every two weeks

## DESCRIPTION OF EACH PART AND FUNCTION

- 1 Air outlet grill – cooled air comes out of this outlet
- 2 Control panel – controls the functions of the air conditioner
- 3 Castors – enables the air conditioner to be easily moved
- 4 Air intake grills
- 5 Remote control receiver – receives commands for the cordless remote control
- 6 Handles
- 7 Evaporator Filter
- 8 Air exhaust hose housing
- 9 Condensate drain – remove cap to drain water from the water tray/tank
- 10 Power cable (cord and plug)
- 11 Air exhaust hose (approx 1.5m long fully extended)
- 12 Hose outlet (connects in window slider)
- 13 Hose inlet (connects to air exhaust hose housing)
- 14 Castor locks (put under castors which stops unit rolling)
- 15 Suckers (not applicable in Australia)
- 16 Window slider (fits in window and hose outlet is attached)
- 17 Drain pan (fits under unit and is used to catch water from the water tank/tray)
- 18 Drain hose (connects to condensate drain when in dehumidifying mode)
- 19 Remote control (also displays set room temperature)

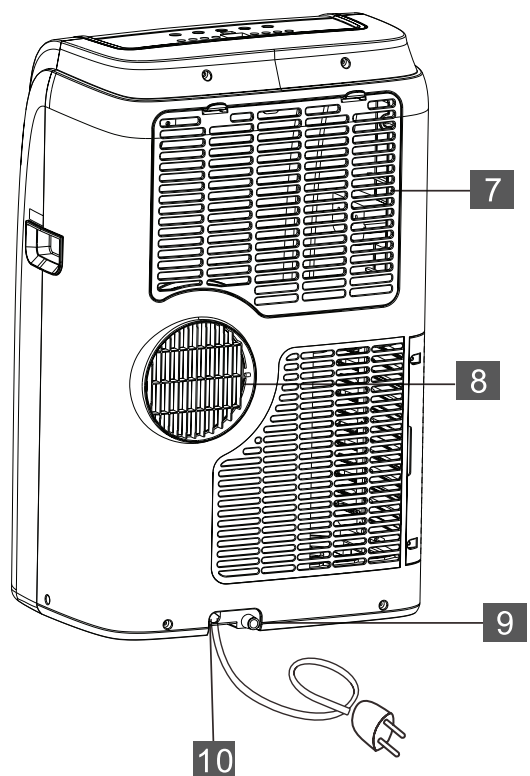
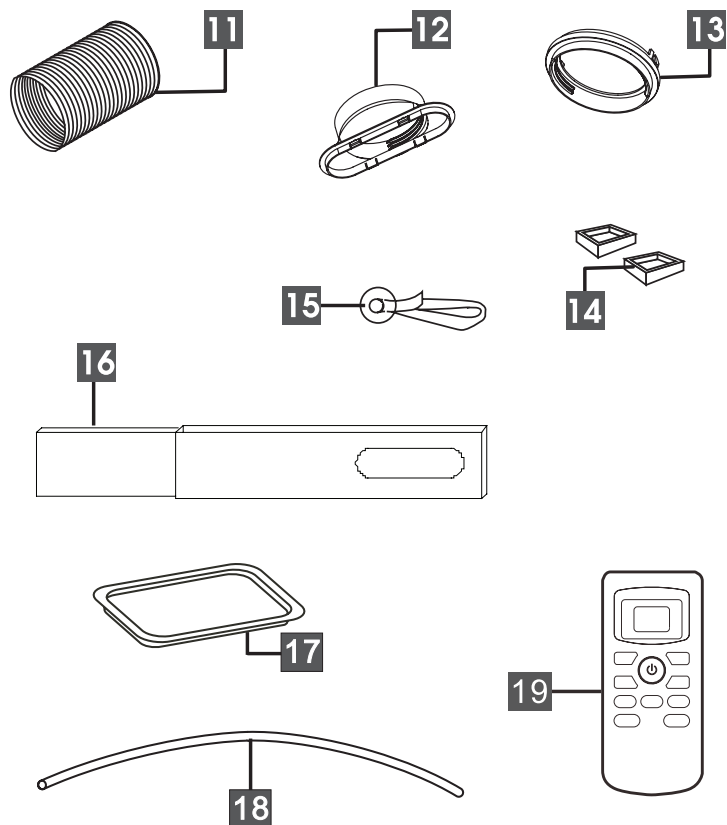
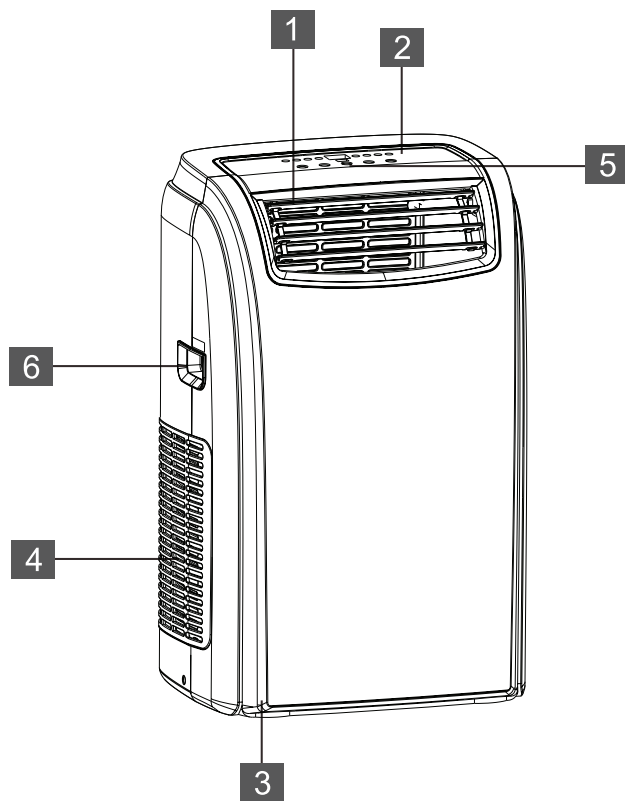

## INSTALLATION

### SELECTION OF INSTALLATION LOCATION

Place the portable air conditioner in a flat location where the air inlets and outlets cannot be covered up. Place the unit no less than 50cm away from a wall or other obstacle. In addition, a minimum 50cm clearance is required from all faces of the air conditioner including the rear face.

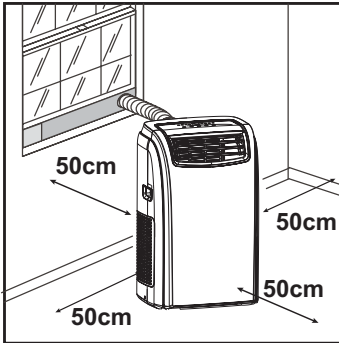

### ASSEMBLY OF EXHAUST HOSE, HOSE INLET, HOSE OUTLET AND WINDOW SLIDER

- Fully extend each end of the exhaust hose by about 10cm and attach the hose inlet and hose outlet to opposite ends by rotating the inlet/outlet in a counter clockwise direction approximately 3 to 4 turns, making sure that the hose wire is well threaded into the hose inlet and outlet. The hose inlet and outlet cannot be installed unless the hose ends have been fully extended.
- Clip the hose outlet into the window slider. Take care to not break the tabs on the hose outlet when disconnecting from the window slider.

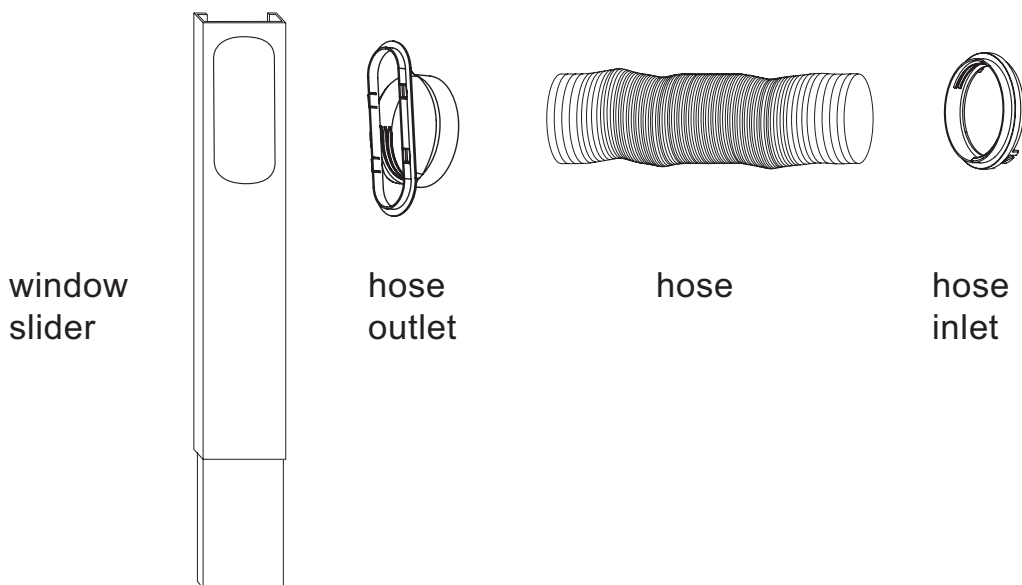

## MOUNTING OF ASSEMBLED AIR EXHAUST HOSE

- Make certain the air intake and outlet grills are unobstructed.
- Push the hose inlet into the air exhaust hose housing lining up the slots with the side lugs. Twist anti clockwise to secure. Twist clockwise to remove.
- Place the hose outlet to the nearest window. The length of the air exhaust hose is between 400mm and 1500mm – use the minimum length when working.
- When mounting try and keep the air exhaust hose horizontal and do not extend its length by attaching it to another hose as this reduces the cooling capacity of the appliance.

If the hose needs to be extended use as few bends as possible.

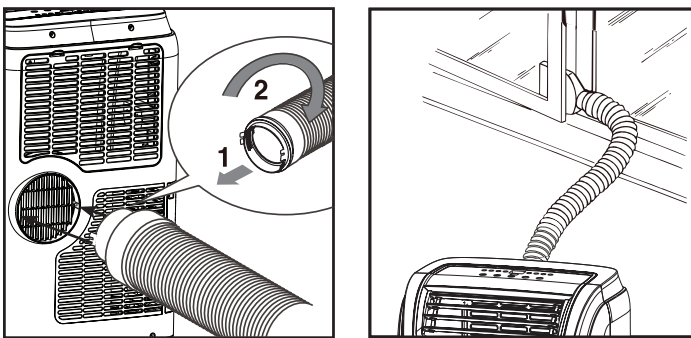

## NOTE

- The exhaust hose should not be longer than 1.5 metres
- Never bend the exhaust hose excessively when the appliance is working
- Always keep the exhaust hose at its shortest length and as straight as possible when the appliance is working
- Never move the appliance by pulling the air exhaust hose attached to the back of the unit
- Do not move the air conditioner when it is operating

# WINDOW SLIDER INSTALLATION

The window slider has been designed to fit most standard “vertical” and “horizontal” window applications. **It may be necessary for you to improvise/modify some aspects of the installation procedures for certain types of windows. Some window types may require the use of cardboard or plastic fillers and/or duct tape to install.** Additional complete window kits may be purchased from POLO to enable pre-installation in windows in other rooms.

Please refer to illustration for minimum and maximum window openings.

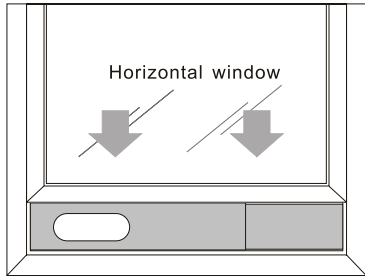

Horizontal window  
Window slider length  
Min. 50cm  
Max. 96.5cm

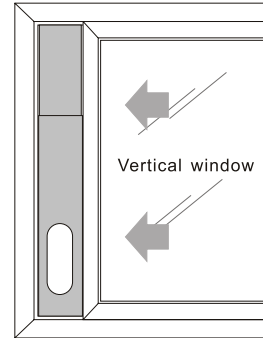

Vertical window  
Window slider length  
Min. 50cm  
Max. 96.5cm

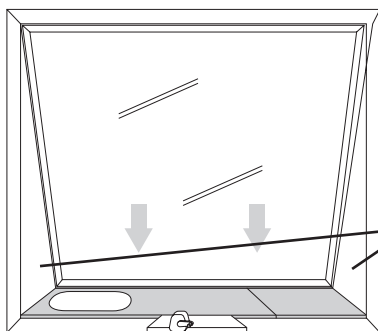
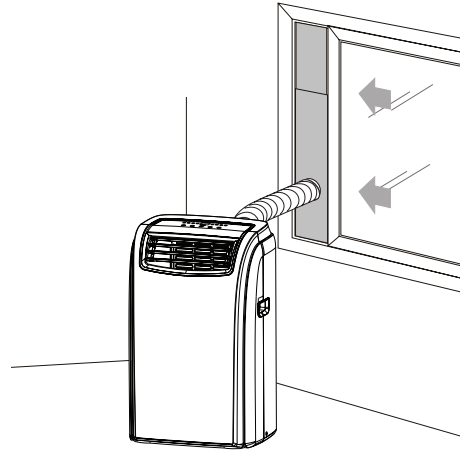
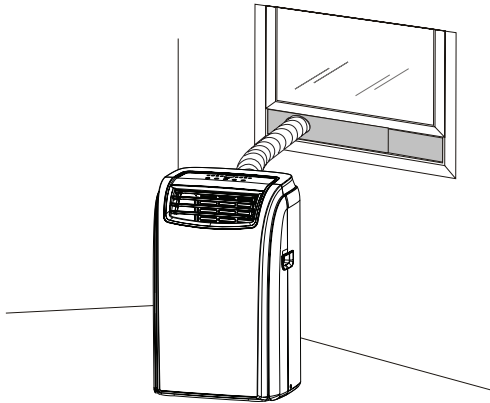

Window slider length  
Min. 50cm  
Max. 96.5cm

Standard door height 210cm.  
Gap can be sealed using  
cardboard and duct tape.  
Additional window sliders  
can also be purchased to fill  
this gap.

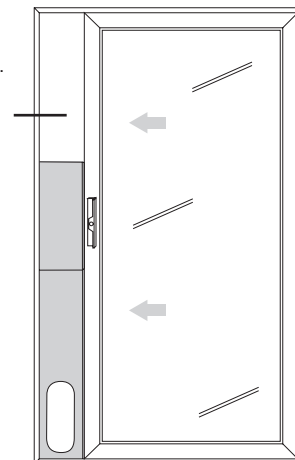

Window (Door) slider height  
Max. 96.5cm



## CONTROL PANEL

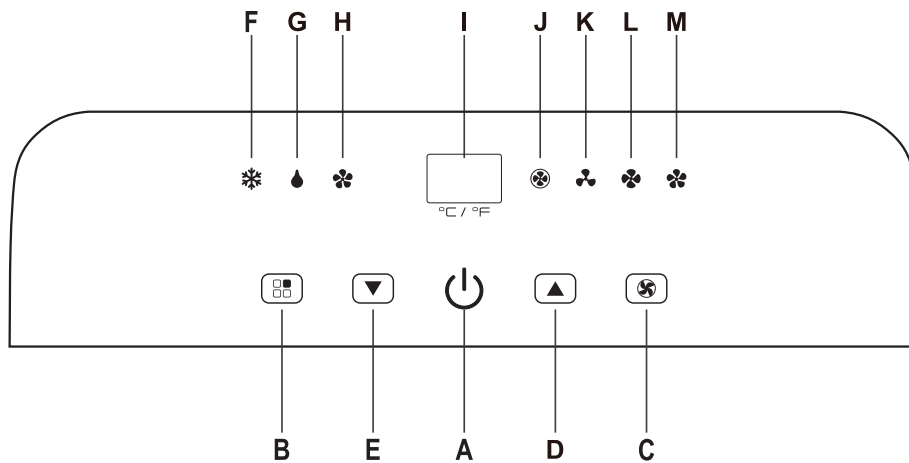

- A: ON/OFF button
- B: MODE selection button
- C: FAN speed selection button
- D: Programmed operation increase temperature
- E: Programmed operation decrease temperature
- F: COOL mode light
- G: DEHUMIDIFYING mode light
- H: FAN mode light
- I: Display area
- J: Auto-speed fan mode light
- K: Low-speed fan mode light
- L: Mid-speed fan mode light
- M: High-speed fan mode light

## OPERATING FROM THE CONTROL PANEL

The operating temperature ranges for cooling and dehumidifying are 18°C to 32°C.

A temperature within this range may be set, but the room may not necessarily reach this set temperature.

If the appliance is turned off during cooling or dry (dehumidifying) operation and turned on again immediately, the unit will wait at least 3 minutes before restarting the compressor.

The control panel enables you to manage all the main functions of the appliance, but to fully exploit its potential, you must use the remote control unit.

### TURNING THE APPLIANCE ON

- Plug into the mains socket.  
Two lines appear on the display indicating that the appliance is in standby.
- Press the  button until the appliance comes on. The last function active when it was turned off will appear.

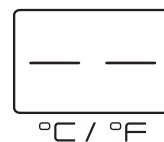

- ✓ Never turn the air conditioner off by unplugging from the mains. Always press the button , then wait for a few minutes before unplugging. This allows the appliance to perform a cycle of checks to verify operation.

## OPERATION

### TURNING THE APPLIANCE ON

Plug into mains socket – do not plug into power boards being used for other appliances.

Two lines appear on the display indicating that the appliance is in stand by.

Press the **ON/STAND-BY** button (**A**). When turned on, the air conditioner starts operating in the same mode as when it was turned off.

Press the **MODE** button (**B**) until the light corresponding to the required mode lights up.

Light (**F**) ☼ : cool mode

Light (**G**) 💧 : dehumidifying mode

Light (**H**) 🌀 : fan mode

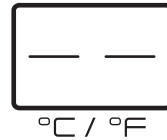

### COOL MODE

Ideal for hot muggy weather when you need to cool and dehumidify the room.

To set operation of the appliance correctly, press the ▲ (**D**) or ▼ (**E**) buttons until the desired temperature is displayed.

Then select the fan speed by pressing the 🌀 (**C**) button until the light corresponding to the required fan speed lights up:

**HIGH:** the cool operates at maximum to reach the required temperature as rapidly as possible

**MED:** reduces noise levels but still maintains a good level of comfort

**LOW:** for quieter operation

**AUTO:** the appliance automatically selects the most suitable fan speed in relation to the temperature set on the digital display.



### DEHUMIDIFYING (DRY) MODE

Ideal for reducing humidity in spring and autumn, during rainy spells or in damp rooms, etc.

In dehumidifying mode the appliance must have the exhaust hose fitted to allow air to be discharged externally.

When the dehumidifying mode is selected, the light (**G**) comes on and “dh” appears on the display.

At the same time, the **AUTO** fan light (**J**) comes on. In this mode, other speeds cannot be selected.



### FAN MODE

Adjust fan speed by pressing the 🌀 (**C**) button (**C**) as described for the cool mode.

The unit will not cool or dehumidify in this mode.

In this mode, **AUTO** cannot be selected

The fan speed selected will be displayed.



## DESCRIPTION OF THE REMOTE CONTROL

1. Mode indicator
2. Sleep indicator
3. Powerful indicator
4. Timer selection
5. Auto-speed indicator
6. Fan Speed indicator
7. (a) Increase (+) temperature button  
 . (b) Decrease (-) temperature button
8. FAN button  
 - Press this button to select fan speed of HIGH/MED/LOW/AUTO
9. POWERFUL button
10. ON/OFF button  
 - Press this button to switch on/off the appliance
11. TIMER button  
 -Press this button to set automatic startup/shutdown
12. SLEEP button  
 -Press this button to on/off sleep function
13. MODE button  
 -Press this button to select the modes of COOL / DRY (Dehumidify) / FAN
14. °C/°F button  
 -Press this button to select the "°C" or "°F" (set temperature in degrees centigrade or fahrenheit)
15. SWING button  
 - Press this button to switch on/off the automatic swing function of the vertical louvres inside the front air outlet grill
16. Swing indicator

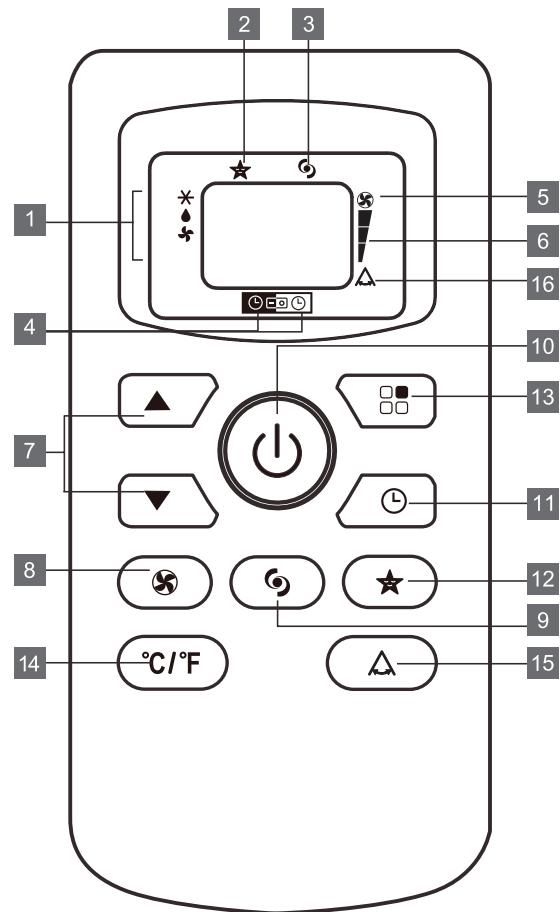

## CORRECT USE

- ✓ Point the remote control at the receiver on the appliance. The remote control must be no more than 7 metres away from the appliance (without obstacles between the remote control and the receiver).
- ✓ The remote control must be handled with extreme care . Do not drop it or expose it to direct sunlight or sources of heat.

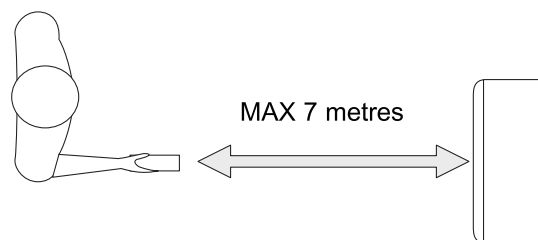

## INSERTING OR REPLACING THE BATTERIES

- Slide and remove the cover on the rear of the remote control;
- Insert two “AAA” 1.5V batteries in the correct position (see instructions inside the battery compartment);
- Replace the cover

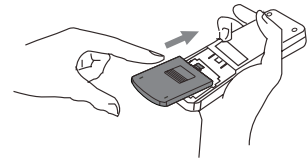

If the remote control is not used for long periods, remove the batteries.

## USING THE REMOTE CONTROL UNIT



The first part of the controls on the remote control are the same as those on the control panel of the appliance.

You should therefore refer to the instructions in the chapter **Operating from the control panel** to turn the appliance on and select the operating mode (**COOL, DRY, FAN**) and the fan speed.

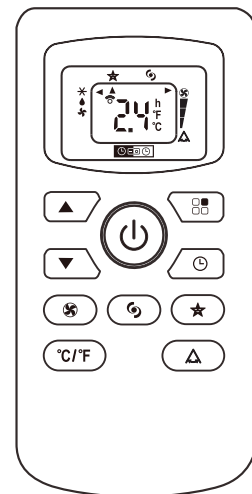
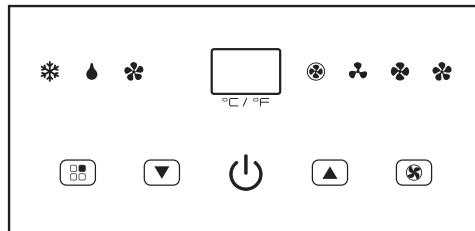
The following section describes the additional functions corresponding to the controls on the bottom part of the remote control.



### COOLING MODE

- Press the “ON/OFF” button to turn the appliance on.
  - Press the “ ” button to select COOL.
  - Set the temperature using the “ ” button.
  - To select fan speed, press the “ ” button repeatedly until the required speed is selected (HIGH/MED/LOW).
- NB: in COOLING mode, the appliance automatically removes excess moisture from the atmosphere.

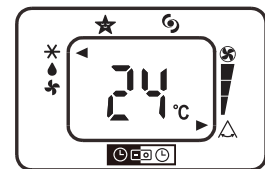

### DRY (Dehumidifying) MODE

- Keep the windows and doors closed for an effective dehumidification.
- When used as dehumidifier only, keep the air exhaust hose connected
- Press the “ON/OFF” button to turn the appliance on.
- Press the “ ” button to select DRY, the fan speed will always be at LOW and can not be adjusted in DRY mode.

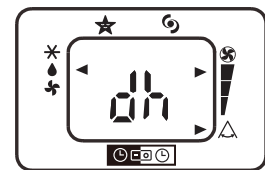

### FAN MODE

- Press the “ON/OFF” button to turn the appliance on.
- Press the “ ” button to select FAN.
- To select fan speed, press the “fan” button repeatedly until the required speed is selected (HIGH/MED/LOW) and fan speed AUTO can not be selected.

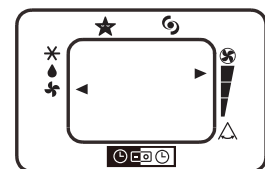

## POWERFUL FUNCTION



- Ideal for summer to cool rooms rapidly.
- Activate by simply pressing the POWERFUL button
- The appliance operates in cool mode at maximum fan speed.  
In this mode no set temperature is displayed and it is not possible to set the temperature or change the fan speed.

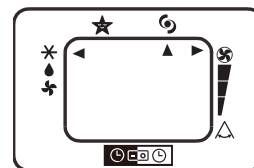

## SLEEP FUNCTION



- This function is useful at night as it reduces the fan speed to low and dims the display on the unit. To set this function correctly:
- Select the operating mode (cool/dry) as described above.
- Press the "★" button, the appliance operates in the previously selected mode.



## SWING FUNCTION



- This function is useful for select the left/right swing of air delivery
- To set this function correctly:
  - select the operating mode (cool/dry/fan/heat ) as described above.
  - Press the "▲" button, the appliance operates in the previously selected mode, the message "▶▲" appears on the remote control to indicate the swing is active.
  - Press the swing button again, the message "▶" disappears to indicate the swing is stopped.

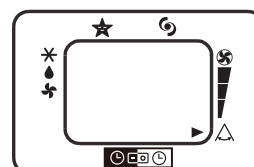

## SETTING THE TIMER

- This timer can be used to delay the appliance start up or shutdown, this avoids wasting electricity by optimising operating periods.

### PROGRAMMED SHUTDOWN

- With the appliance on, press the "TIMER" button, the "⌚" is displayed under the "📺".
- Set the time when you want the appliance to switch off using the "▲/▼" buttons (from 30 minutes to 24hours)
- During the first ten hours you can select half intervals. for times longer than ten hours, one hour intervals can be selected.
- Press the "⌚" button again to confirm the setting, the TIMER symbol light "📺" on the remote LCD lights up to indicate the timer is activated.
- At the end of the set time the appliance switches off automatically.
- To cancel the TIMER setting. press the "⌚" button again whenever during the set time.

#### PROGRAMMED START UP

- Turn on the appliance and set the working mode (COOL or DRY) you require when the appliance starts up from standby, for example, cooling mode, 25°C, fan speed high.
- Press "ON/OFF" button to switch into STANDBY.
- Press the "⌚" button twice, the time is displayed and "🕒" symbol.
- Set the time when you want the appliance to switch off using the "⏸" buttons (from 30 minutes to 24hours)
- During the first ten hours you can select half intervals. For times longer than ten hours, one hour intervals can be selected.
- Press the "⌚" button again to confirm the setting, the TIMER symbol light "🕒" on control panel light up to indicate the timer is activated.
- At the end of the set time the appliance switches on automatically and operates in the same working mode as prior to switching into STANDBY, for example cooling mode, 25°C, fan speed high.
- To cancel the TIMER setting. press the "⌚" button again whenever during the set time

## WATER DRAINAGE METHOD

This air conditioner is equipped with the very latest MIST technology which means that the water tank NEVER needs emptying even in high humidity areas. Water drainage will generally only be required at the end of the season (see End of Season Operations – page 15)

However, the mist technology does not operate when the unit is in dry (dehumidifying) mode. Thus, the tank may require emptying on occasions when operating for long periods in this mode.

### NOTE

As a safety measure, to positively prevent water spillage, the air conditioner is equipped with a fail safe device, if, the water tank fills. The unit will completely stop, the control panel displays “FL” (FULL TANK) as mentioned in SELF-DIAGNOSIS in page 17, the compressor and fan will not restart until the tank has been drained.

Before draining the water tank (tray) take care not to move the air conditioner as water may spill onto the floor.

Turn the air conditioner off using the on/off switch on the unit or remote control. Then drain the water tank by unplugging the drain outlet and allowing the water to flow onto the drain pan. The drain pan will not hold the full contents of the water tank. A number of fills of the drain pan are required. It may be easier (after 3 or 4 pans have been drained in order to avoid accidental spillage when shifting the air conditioner) to wheel the unit outside, remove the drain plug and drain the water onto the ground.

The water tank is considered sufficiently drained when no more water flows from the drain outlet.

Restart the air conditioner by pressing the on/off button. Ensure that the unit is in COOL or DRY mode. The compressor will start approximately 3 minutes after the unit is switched on.

### NOTE

To completely drain all water from the water tank, tilt the unit by lifting it slightly upwards from the front until no more water drains from the outlet.

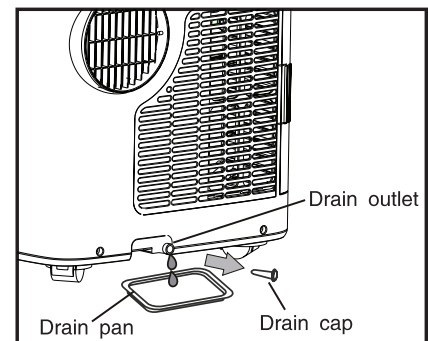

## CONTINUOUS DRAINAGE

When operating in dry (dehumidifying) mode continuous drainage can be used to avoid the trouble of emptying the water tank/tray.

To operate the continuous drain method:

- (1) Empty the water tank completely
- (2) Connect one end of the drain hose to the bottom drain outlet. Pick the hose end that has a tight fit on this outlet and lead the other end to the outdoors or to a place where it can drain freely
- (3) Turn on the appliance and select dry mode

Please be sure that there is slope on the drain hose to enable water to flow through the drain hose continuously.

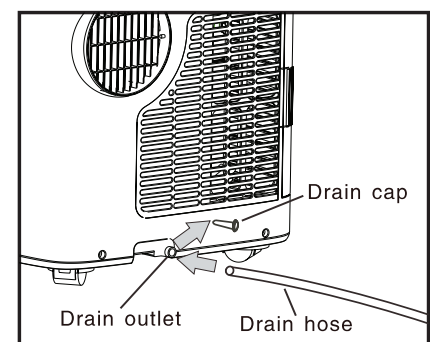

## MAINTENANCE AND SERVICE

### MAINTENANCE METHODS

- Before undertaking cleaning or maintenance, turn the appliance off by pressing the ON/OFF button, then always unplug the appliance from the power supply outlet.
- Do not use chemical solvent to clean the surface of the unit. Never spray insecticides or similar in the vicinity of the unit.
- Clean the surface of the unit with a damp cloth, then dry with a dry cloth.

### CLEANING THE AIR FILTER

Clean the evaporator filter every two weeks of operation. This will keep the air conditioner working efficiently.

#### (1) Evaporator Filter (**Fig 1**)

- (a) Push down on the tabs to remove the evaporator filter
- (b) Wash the filter by immersing it gently into warm water (about 40 degrees celsius with a dishwashing detergent)
- (c) Rinse the filter of detergent and dry it thoroughly in a shaded place
- (d) Insert the filter back to its original position and then attach the intake grill to the appliance

#### (2) Condenser Filters

The condenser filters are in two pieces.

- (a) Remove the two screws securing the plastic cover retaining the first filter. Remove filter from housing. (**Fig 2**)
- (b) Grasp plastic tab and remove second filter (**Fig 3 & 4**)
- (c) Clean as per instructions for evaporator filter
- (d) After cleaning reinsert filter part with plastic tab first. Then reinstall second filter part in plastic housing and secure with the two screws.

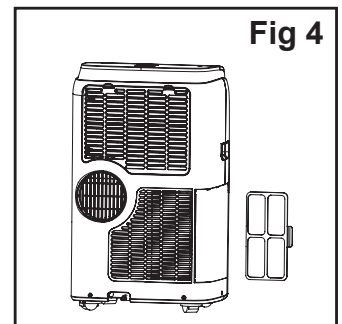
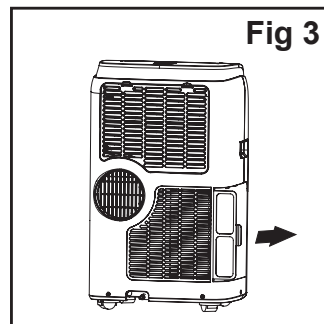
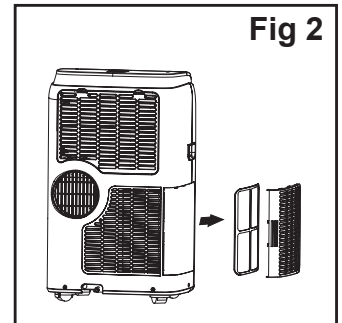
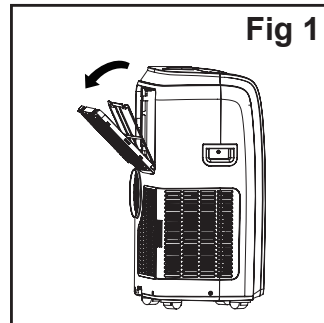

### END OF SEASON OPERATIONS

- Switch off the unit and disconnect the plug from the power supply outlet.
- Remove the plug from the bottom drain outlet to drain the water onto the drain pan and dispose of the water. Tilt the unit by lifting it at the front to ensure all water is removed from the water tank. Then operate the unit in fan mode for half a day until the pipe is dry.
- Wind the cable around the cable hooks on the back of the appliance.
- Wrap the appliance with the plastic bag and keep it in a dry place.





## TROUBLESHOOTING

Before seeking repair or service, please check the following:

PROBLEM	CHECK	ACTION
No power to Air Conditioner	<ul style="list-style-type: none"> <li>• Is A/C plugged into power supply outlet?</li> <li>• Has fuse blown (circuit breaker switched off) or A/C switched off?</li> </ul>	<ul style="list-style-type: none"> <li>• Insert power plug securely into power supply outlet and turn power on.</li> <li>• Turn A/C off, replace fuse wire (or turn on circuit breaker), turn A/C back on.</li> </ul>
Power to Air Conditioner, but unit does not operate.	<ul style="list-style-type: none"> <li>• Is timer on?</li> </ul>	<ul style="list-style-type: none"> <li>• Wait for timer to count down or cancel timer setting by pressing TIMER button.</li> </ul>
Air Conditioner does not cool after turning on.	<ul style="list-style-type: none"> <li>• Is air coming out of the exhaust hose?</li> </ul>	<ul style="list-style-type: none"> <li>• If not, wait three minutes from turning on, safety device prevents compressor (which provides cooling) being turned on for about three minutes</li> </ul>
The compressor and fan has stopped.	<ul style="list-style-type: none"> <li>• Is "Ft" displayed on LCD?</li> </ul>	<ul style="list-style-type: none"> <li>• Drain water.</li> </ul>
Air Conditioner not cooling satisfactorily.	<ul style="list-style-type: none"> <li>• Cooling power not enough for the conditions of area or room?</li> <li>• Air exhaust hose blocked?</li> <li>• Air exhaust hose bent over?</li> <li>• Standard air exhaust hose has been extended longer than 1.5m?</li> <li>• Air exhaust hose detached?</li> <li>• Window/door opened?</li> <li>• Air inlet/outlet blocked?</li> <li>• Air filter dirty?</li> <li>• Fan speed set at low?</li> <li>• Has the temperature been set low enough?</li> </ul>	<ul style="list-style-type: none"> <li>• Ensure A/C is suitable for conditions of area and room.</li> <li>• Clear blockage.</li> <li>• Always keep the hose at its shortest possible length and as straight as possible.</li> <li>• Remove extension, always keep standard hose length less than 1.5m.</li> <li>• Connect the hose.</li> <li>• Close the windows/doors to room being cooled.</li> <li>• Clear blockage.</li> <li>• Clean air filter.</li> <li>• Set suitable higher speed.</li> <li>• Reduce temperature setting.</li> </ul>
Air Conditioner vibrates.	<ul style="list-style-type: none"> <li>• Is it leaning or unbalanced?</li> </ul>	<ul style="list-style-type: none"> <li>• Place on level floor.</li> </ul>
Lt/PF/FT appears on the display.	<ul style="list-style-type: none"> <li>• See self-diagnosis section.</li> </ul>	

## SELF-DIAGNOSIS

The appliance has a self diagnosis system to identify a number of malfunctions. Error messages are displayed on the appliance display.

IF IS DISPLAYED,	WHAT SHOULD I DO?
 <b>LOW TEMPERATURE</b> (frost prevention)	The appliance is fitted with a frost protection device to avoid excessive formation of ice. The appliance starts up again automatically when the defrosting process is completed.
 <b>PROBE FAILURE</b> (sensor damaged)	If this is displayed, contact your local authorised service centre.
 <b>FULL TANK</b> (safety tank full)	Empty the internal safety tank, following the instructions in the "End of season operations" paragraph.

## SPECIFICATIONS

### TECHNICAL SPECIFICATIONS

Polocool - KN 10C

Rated voltage – 240 volts

Rated power input – 1130 watts

Refrigerant – R410a – 440gm

Cooling capacity – 2,900 watts (10,000 BTU)

Polocool – KN 12C

Rated Voltage – 240 volts

Rated power input 1200 watts

Refrigerant – R410a – 600gm

Cooling capacity – 3,500 watts (12,000 BTU)

Polocool – KN 14C

Rated Voltage – 240 volts

Rated power input 1600 watts

Refrigerant – R410a – 460gm

Cooling capacity – 4,100 watts (14,000 BTU)

### LIMIT CONDITIONS OF AIR CONDITIONING

Room ambience in air conditioning

Temperature 21C – 32C

Relative humidity 60% - 90% (COOLING)

### SIZE OF APPLIANCES

Width 435mm

Height 715mm

Depth 350mm

