

BLANCO

Instruction Manual for Induction Cooktops BIC63T

Dear Customer,

Thank you for buying a **BLANCO Induction Cooktop**.

Before we continue telling you about this cooktop, we cordially invite you to become part of the Blanco family by subscribing online. Please visit our website where you can easily register for product/cooking demonstrations, and request Blanco's gourmet recipes. Go to www.blanco-australia.com and fill in the subscription details in the contact us/showrooms section.

You will find that the clean lines and modern look of your **Blanco Induction cooktop** blends in perfectly with your kitchen décor. It is easy to use and performs to a high standard.

Blanco also makes a range of products that will enhance your kitchen such as ovens, rangehoods, dishwashers, microwaves, sinks and taps. There are models to complement your new **Blanco Induction cooktop**.

Of course, we make every effort to ensure that our products meet all your requirements, and our Customer Relations department is at your disposal, to answer all your questions and to listen to all your suggestions.

Please complete the warranty card and keep your receipt as proof of purchase. Retain all documents relating to the purchase of this product.

Blanco is committed to providing increasingly efficient products that are easy to use.

Read these instructions carefully before using your cooktop and keep them in a safe place.

If you follow the instructions, your cooktop will provide you with many years of good service.

TABLE OF CONTENTS

SECTION	PAGE NO.
Important Safety Instructions	1-2
Appliance Details	2
Operating Instructions	3-6
Cleaning	7
Electrical Connections	8
Installation	9-10
Trouble Shooting and Error Codes	11-12
Warranty	16

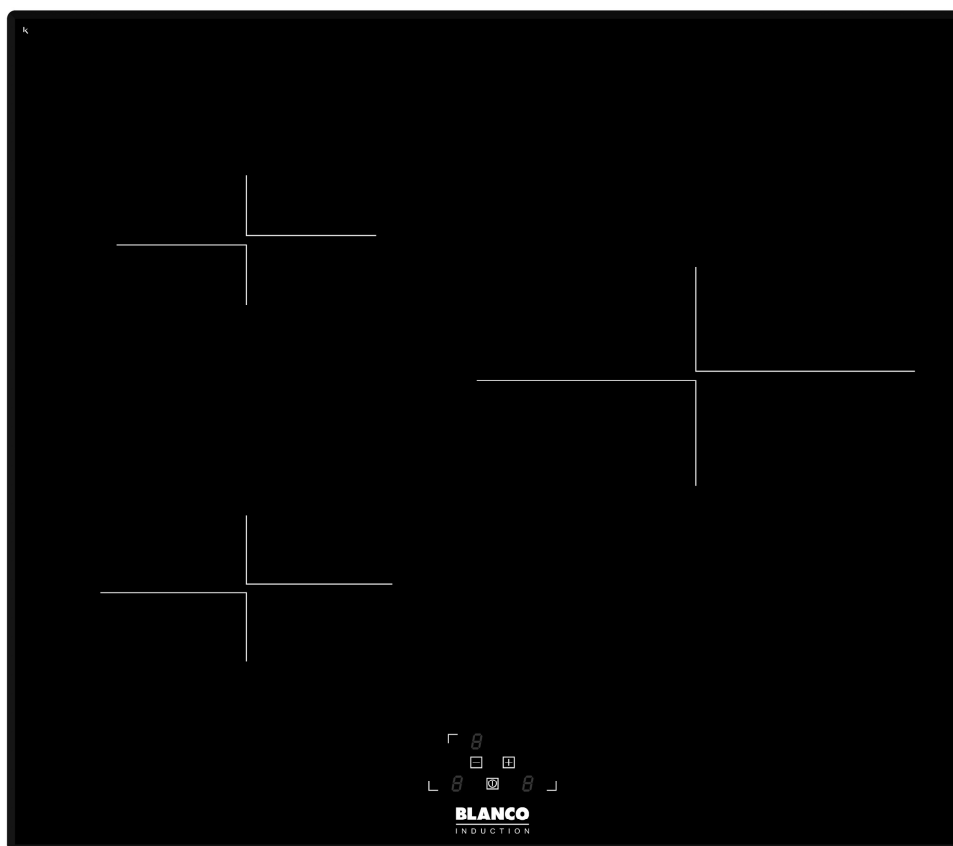

IMPORTANT SAFETY INSTRUCTIONS

IMPORTANT: **Read the assembly instruction section and safety precautions of this booklet carefully before removing the contents of this carton.**

1. This appliance is not intended for use by persons (including children) with reduced physical, sensory or mental capabilities, or lack of experience or knowledge, unless they have been given supervision or instruction concerning the use of the appliance by a person responsible for their safety. Children should be supervised to insure that they do not play with the appliance.
2. After removing the packaging, make sure to check if there is any damage to the appliance. If there is any damage, never attempt to use the appliance and immediately contact your Authorised Service Centre. As packaging materials can be dangerous to children, they need to be collected immediately and put out of reach.
3. In certain circumstances electrical appliances may be a danger hazard. Check the conformity of voltage and power settings, which are specified on the information plate attached to the appliance and/or packaging, with the usage conditions available.
4. Do not place heavy objects in or on these appliances, use for storage or as a cutting surface as sharp edges can damage the surface. This appliance is designed for cooking food only. Use flat based, stable, inductive cooking rated cooking vessels only.
5. This appliance is designed for domestic household use only and for the cooking of domestic food products. Use as a commercial appliance will void the warranty. It should not be used in a marine environment or outdoors and must be fully built in. Do not use the appliances until fully installed.
6. A means for disconnection must be incorporated in the fixed wiring in accordance with the wiring rules.
7. The electrical connection must be accessible after installation. The appliance must be electrically isolated before any maintenance can be performed.
8. The appliance is not intended to be operated by means of an external timer or separate remote control system.
9. Electrical connection must be made as per local wiring rules and regulations. Do not disconnect the appliance with wet hands or bare feet, and do not disconnect the power cord with extreme force.
10. Ensure that the kitchen is well ventilated or mechanical ventilation is in use while cooking on this appliance.
11. Do not store or use flammable materials or aerosols near the cooktop. Items made from aluminium, plastic, plastic film & sugar based foods should also be kept away from the appliance, as they may fuse to the surface.
12. Heat from the underside of the unit will be expelled by inbuilt fans – do not block. It is essential that the installation instructions relating to ventilation are followed, otherwise the appliance can fail.
13. **WARNING** - The cooktop will become hot during and directly after use. Do not touch the surface during this time, as it may be hot and can cause burns. To avoid burns, children should be kept away.
14. Cleaning may only be commenced on the appliance once it has cooled down and is turned off. Failure to clean properly can damage the unit. Do not use a steam jet or any other high pressure cleaning equipment to clean the appliance.
15. When the appliance is not being used, turn the appliance off. Do not cover with any type of protection sheet or cloth, as these may ignite and burn.
16. Where this appliance is installed in a caravan, it shall NOT be used as a space heater.
17. Do not modify this appliance. Remove all labels from the glass cooktop before operating.
18. Do not use harsh abrasive cleaners or sharp metal scrapers to clean the glass surface as they can scratch the surface, which may result in the glass shattering. Clean the glass using a warm damp cloth (e.g. dishcloth) and dry it with a soft dry tea towel.
19. Do not install this appliance above a dishwasher or clothes dryer, as the steam may damage the internal circuitry.
20. If any cracking or chipping is noticed on the cooktop, turn the appliance off immediately and call your Authorised Service Centre.

21. All cabinetry and materials used in the installation must be able to withstand a minimum temperature of 80°C whilst in use. Certain types of vinyl or laminate kitchen furniture are particularly prone to heat damage or discolouration at temperatures below the guidelines given above. Any damage caused by the appliance being installed without adhering to the temperature limits set out above will be the liability of the owner. To avoid any hazards, limit access to the under-bench section of the cooktop.
22. The appliance must be installed and put into operation by an authorised person under the conditions provided by the manufacturer in this manual. The manufacturer cannot be held responsible for any damage that might occur due to faulty installation.
23. Damage can occur to bench tops if pots and pans are allowed to overlap the bench top. This can result in heat being transferred to the bench top. Ensure that correct sized pots & pans are used. Pans should be lifted on and off the cooktop surface and not dragged. Cooking zones should not be switched on without cookware placed on it. Do not place empty cookware onto the cooking zones when in use.
24. Do not leave the cooktop unattended while cooking with solid or liquid oils. There may be flaming up in conditions of extreme heating. Never pour water onto the flames occurring from oil. Immediately turn the cooktop off and cover the pan with a lid or fire blanket in order to smother the flame.
25. Users with pacemakers should keep their upper body at least 30cm away from any operational inductive cooking zone. If in doubt, please consult your doctor before use.
26. Do not place metal objects such as spoons or pan lids onto the cooktop as they may become hot or cause damage to the surface.
27. A small amount of noise will sometimes be heard as elements turn on & off during operation. This is normal & not a fault. The sound of the fans will vary depending on cooking zone usage.



DO NOT

DO NOT

DO NOT

OPERATE THIS APPLIANCE BEFORE READING THE INSTRUCTION BOOKLET
 PLACE ARTICLES ON OR AGAINST THIS APPLIANCE
 STORE CHEMICALS OR FLAMMABLE MATERIALS OR
 SPRAY AEROSOLS NEAR THIS APPLIANCE

APPLIANCE DETAILS

ELECTRICAL DETAILS:

COOKTOPS:

Rated Voltage: Single phase 220-240Vac 50Hz, 2-phase 380-415Vac 50Hz: 6700W.

This information can be found on the rating plate (identification plate) affixed to the underside of the appliance.

Type	Total Power	Position of the heating zone	Nominal Power*	Booster Power*	Diameter	Minimum diameter detection
Induction	6700 W	Front left Rear left Right	2300 W 1100 W 2300 W	3000 W 1400 W 3000 W	220 mm 180 mm 270 mm	100 mm 90 mm 110 mm

* The given power may change according to the dimensions and material of the pan. Nominal power on cooking zones may adjust lower when the boost function is being used on other cooking zones, to keep the appliance from exceeding the rated total power.

COOKTOP – Directly wired to mains supply.

SIZES:

Relevant Sizes:	LENGTH (mm)	WIDTH (mm)	HEIGHT (mm)
Cooktop Size (BIC63T)	590	520	58
Cut-out Size (BIC63T)	560	490	-

OPERATING INSTRUCTIONS

The basic layout of the induction cooktop is shown in the diagrams below.

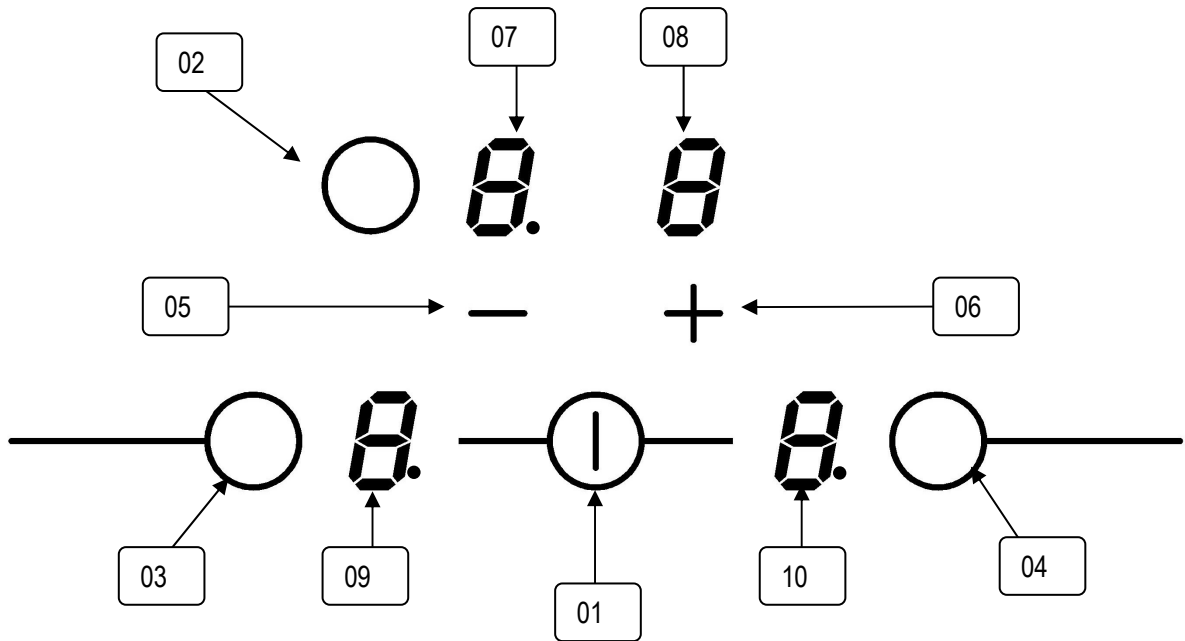

	DESCRIPTION		DESCRIPTION
01	On/off power touch control	07	Cooking Zone Power (LHR) and timer LED display
02	Timer/Zone Power (LHR) touch control	08	Timer LED display
03	Timer/Zone Power (LHF) touch control	09	Cooking Zone Power (LHF) LED display
04	Timer/Zone Power (RH) touch control	10	Cooking Zone Power (RH) LED display
05	Decrease Power/Time touch control		
06	Increase Power/Timer touch control		

The induction cooktop appliance is operated by touching the control buttons, with the functions confirmed by LED displays and acoustic signals. Clean glass surface with a damp cloth and dry before use.

Turning On and Turning Off the Cooktop Appliance

NOTE: Do not operate the cooktop without first placing a suitably sized cooking vessel on the appropriate cooking zone. If the correct sized cooking vessel is not placed on the cooking zone, the *Cooking Zone Power display* will indicate pan not detected. Settings can be changed, but the zone will not work until the pot is replaced.

If the appliance is in *Stand-By-Mode*, it is put into *Operating-Mode* by pressing the *On/Off touch control* for at least 1 second. A beep signal indicates the successful operation acoustically.

On all *Cooking Zone Power Displays* a '0' will appear. The decimal points on the *Cooking Zone Power Displays* will flash until a cooking zone is selected.

- If there is no operation within 20 seconds, all the *Cooking Zone Power Displays* will automatically turn off and the appliance will be re-set into *Stand-By-Mode*.
- If *On/Off* is pressed for more than 1 second (in *Operating-Mode*), the appliance is switched off and is set into the *Stand-By-Mode* again. The appliance can be turned off by pressing *On/Off* at any time.
- If there is any residual heat remaining in a cooking zone, this will be indicated in the corresponding *Cooking Zone Power Display* as a red "H".
- Note: All cooking zones have a pre-set limit on the length of time they will run without any setting changes (table further in the manual).

Selecting A Cooking Zone

1. Select a single cooking zone by pressing the corresponding *Cooking Zone Select touch Sensor* (02, 03 or 04), and the *LED display* (07, 09 or 10) of the chosen cooking zone stays bright while the others dim.
2. For the selected cooking zone, you can set or adjust the power level between 1-9 by touching the *Increase power/timer touch control* (06) or *Decrease power/time touch control* (05). All of the other cooking zone displays will have a visible 'O', value (if in use) or 'H' (if recently used).
 - If left idle for more than 10 seconds, the LED for the chosen cooking zone display will dim down (the cooking zone is no longer selected). Press the *Cooking Zone Select touch Control* again to select the cooking zone again. Other cooking zones can be selected without waiting for the previous one to become inactive.
 - The *Cooking Zone Power LED Display* (10) works on a thermostat system. This means that the cooking zone will switch on and off in order to remain at the chosen Power Level. NOTE the cooking zone will remain on for longer periods if a higher Power Level is chosen, alternatively the cooking zone will be on less regularly on lower Power Level Settings.

Turning Off Individual Cooking Zones

A particular cooking zone can be turned off in 2 different ways:

1. Select the cooking zone that needs to be turned off. Simultaneously press the *Decrease power/time touch control* (05) and the *Timer/Zone Power touch control*, for that cooking zone. A beep signal will sound and "0" appears in the *Cooking Zone Power LED Display* of the selected cooking zone.
2. Reduction of the power level to "0" by operating the *Decrease power/time touch control*. If there is residual heat from this hotplate remaining, a red 'H' will be shown in the *Cooking Zone Power LED Display*.

The Boost Function

The Boost function is available at each cooking zone. It is used to speed up the initial heat up time (say boil a pot of water) and only runs for a short time (5 minutes).

Select a cooking zone and keep pressing the *Increase power/timer touch control* (06) until the display changes from 9 to "P". The power boost function is now active. Once the 5 minutes has passed, the cooking zone power level will drop to 9 (the *Cooking zone power LED* will first flash for 2 seconds, and then change to 9).

- Note: The Boost function uses significantly more power than the nominal power (see appliance details), and it is recommended that the power boost function be used on only one zone at a time. If used in conjunction with other cooking zones, the max power available on the other cooking zones may be reduced to keep power usage within the total allowed.

To disable the Boost function, press the *Cooking Zone Select touch Control* for the cooking zone again (so the *LED Display* is bright) and adjust the power level with the *Decrease power/time touch control* (05). The *Cooking zone power LED* will no longer show "P".

Activating The Key Lock

The key lock is used to set the appliance up so that it cannot be operated without disabling the lock. This is a useful feature when cleaning down the glass, or to stop children playing with the controls.

1. Put into *Operating-Mode* by pressing the *On/Off touch control* for at least 1 second.
2. When the LED displays light up, simultaneously press the *Decrease power/time touch control* (05) and *Timer/Zone Power (RH) touch control* (04) within 10 seconds (a beep will sound, but no change will take place with the LED displays if successful). Note: if any other control button is pressed before this, the operation must be restarted.
3. Within 5 seconds, press the *Timer/Zone Power (RH) touch control* (04) again. The *LED display* (07, 09 and 10) will change to "L". The controls are now locked and no operation except turning the appliance from *Stand-By-Mode to Operating-Mode* and back is available.
4. To unlock the control panel, repeat the sequence above, but instead of pressing the *Timer/Zone Power (RH) touch control* at the end of the sequence, press the *Decrease power/time touch control*. When successful, all displays will turn off and a beep will sound. The appliance is now ready to put into *Operating-Mode*.
 - The Key Lock will stay active even if the power is disconnected for a short period of time.

Minute Minder Function

The Minute Minder function is a timer that does not affect any operation on the appliance, but can be used as a reminder to take action (add a spice, turn meat etc.).

1. The appliance must be in *Operating-Mode* (any cooking zone can be running).
 2. Press the *Increase power/timer touch control* (06) and *Decrease power/time touch control* (05) simultaneously. The LED displays (09 & 10) will turn off, and the LED displays at the top of the control panel (07 & 08) will be bright showing "00".
 3. Within 10 seconds, adjust the time setting by using the *Increase power/timer touch control* and *Decrease power/time touch control* (from 00 to 99 minutes) until the desired length of time is set. The timer starts as the last button is pressed. 10 seconds after the last button is pressed, the LED displays (07, 09 & 10) will return to normal (showing the cooking zone power levels).
 4. When the set time has passed, the appliance starts to beep, and the LED displays at the top of the control panel (07 & 08) will flash "00". Press any button to turn the sound off and return the appliance to display its operations as before.
- The Minute Minder time can be adjusted at any point by activating the function and adjusting as above. To disable the function, adjust the time to "00".

Timer Function

The timer function differs from the Minute Minder function in that it will turn off a cooking zone at the end of the time. It can be set for one or more cooking zones (each working independently).

1. First set up the appliance with cookware placed on cooking zones and set all power levels.
2. Activate a cooking zone with its *Timer/Zone Power touch control* and within 10 seconds press the *Increase power/timer touch control* (06) and *Decrease power/time touch control* (05) simultaneously. The LED displays (09 & 10) will turn off, and the LED displays at the top of the control panel (07 & 08) will be bright showing "00" (the difference to setting the Minute Minder function time is that the decimal point of the display for the selected cooking zone is also flashing).
3. Adjust the time setting by using the *Increase power/timer touch control* and *Decrease power/time touch control* (from 00 to 99 minutes) until the desired length of time is set. The timer starts as the last button is pressed. 10 seconds after the last button is pressed, the LED displays (07, 09 & 10) will return to normal (showing the cooking zone power levels). The cooking zone that has just had the timer set will now have its decimal point lit.
4. Another timer function can now be set on a different cooking zone, or power levels can be adjusted. If a change needs to be made to a timer, the above can be repeated. Changing the value to "00" will disable the timer on the selected cooking zone (but not the power level).
5. When a timer function finishes, the appliance will start to beep indicating the cooking zone has finished. The LED displays at the top of the control panel and the decimal point on the LED display of the cooking zone will flash "00" for 2 minutes (unless a button is pressed) and then the displays will return to normal. Any other timer functions that are running will continue (cooking zone decimal points on) until the next timer is finished. If all timer functions finish and there are no other cooking zones active, the appliance will return to the *Stand-By-Mode* after the alarm finishes.

TOUCH CONTROL SAFETY FUNCTIONS

The following safety functions are available to avoid unintended operations of the cooktop control:

Overflow Cut-off Function

The cooktop has a sensor that detects if liquids are spilled on the control panel. When this happens, an error function (Er03) will flash and the control panel will cease to operate. The easiest remedy is to clean/dry the control panel with a moistened cloth and leave for a minute to dry. Once dry, the control panel will be usable again.

Pan Detection Failure

If a cooking zone is activated and undersized cookware, incorrect material cookware or no cookware is detected, the symbol U will be displayed on the cooking zone LED display and the cooking zone will be disabled. Place or replace cookware on the cooking zone.

Residual Heat Functions

After all cooking processes there is some heat stored in the glass top called residual heat. The control can calculate roughly how hot the glass is in the worst case. If the calculated temperature is higher than + 60 ° C, then this will be indicated in the corresponding *Cooking zone power LED display* with a red "H" after the cooktop has turned off. The residual heat display is shown as long as the calculated cooking zone temperature is > + 60 ° C.

EXAMPLES OF COOKING ZONE POWER SETTINGS

(The values below are indicative)

1 to 2	Melting Reheating	Sauces, butter, chocolate, gelatine. Dishes prepared beforehand.
2 to 3	Simmering Defrosting	Rice, pudding, sugar syrup. Dried vegetables, fish, frozen products.
3 to 4	Steam	Vegetables, fish, meat.
4 to 5	Water	Steamed potatoes, soups, pasta, fresh vegetables.
6 to 7	Medium cooking Simmering	Meat, eggs, sausages. Goulash, roulade, tripe.
7 to 8	Cooking	Potatoes, fritters, wafers.
9	Frying, roasting Boiling water	Steaks, omelettes, fried dishes. Water.
P	Frying, roasting Boiling water	Scallops, steaks. Boiling large quantities of water.

COOKING ZONE TIME LIMITS (BY POWER LEVEL)

POWER LEVEL	OPERATING TIME (HRS:MIN)
1	8:36
2	6:42
3	5:18
4	4:18
5	3:30
6	2:18
7	2:18
8	1:48
9	1:30

CLEANING



NOTE: Cleaning and maintenance operations must only be carried out when the cooktop is cool (all residual heat indicators are off).

The appliance should be disconnected from the power outlet or turned off at your isolation switch before commencing any cleaning process.

Do not use plastic, plastic coated or aluminium cooking equipment on this appliance.

CLEANING THE COOKTOP

All cookware used on this appliance should be rated for induction cooking by the manufacturer. Cookware with rough bases should not be used as they can scratch the glass ceramic surface. The base of the good cookware should be as thick and flat as possible. Before use, make sure that cookware bases are clean and dry.

Always place the cookware on the cooking zone before it is switched on. If possible, always place the lids on the cookware. The base of any cookware used must not be smaller or larger than the cooking zones; they should be the proper size as indicated below, so as not to waste energy.

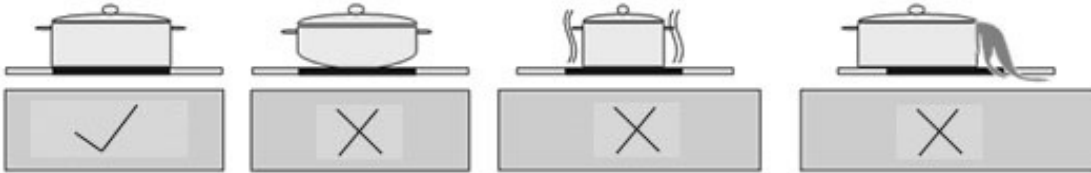

Before cleaning the cooktop, first isolate the cooktop from the power. Once done, ensure that there is no residual heat stored in the appliance. The glass is very resistant to high temperature and overheating. If there is residual heat stored in the appliance, the related residual heat indicator lamp will be on. In order to avoid burns, let the appliance cool down.

Remove all spilt food and fat with a clean damp, warm, slightly soapy, dishcloth. Rinse cloth and wipe cooktop again until clean, then wipe the cooktop dry with a clean tea towel or dry soft cloth.

If aluminium foil or plastic items are accidentally melted on the glass surface, they should be immediately removed from the hot cooking area with a scraper specifically for glass. This will avoid any possible damage to the surface. This also applies to sugar or food containing sugar that may be spilled on the cooktop. Enamelled steel, aluminium & copper will leave a residue on the surface that should be removed immediately or permanent damage may occur.

In the event of other food melted on the cooktop surface, remove the dirt when the appliance has cooled down. Use cleaner for glass ceramic or stainless steel when cleaning the surface.

Do not use abrasive sponges to clean the glass surface. These materials may damage the surface.

Do not use chemical detergents, sprays or spot removers on the glass surface. These materials may cause fire or the glass colour to fade. Clean with a damp, warm, slightly soapy, dishcloth.

WARNING: Using cookware that is too large can cause discolouration or damage to the cooktop surface around the cooking zones, which is **NOT** covered under warranty.

ELECTRICAL CONNECTIONS



LOCAL AUTHORITY REQUIREMENTS

Installation is only permitted by a licensed electrician, and carried out according to instructions provided by the manufacturer. Incorrect installation might cause harm and damage, for which the manufacturer accepts no responsibility.

ELECTRICAL INSTALLATION

Before carrying out the connection to the power supply, the voltage rating of the appliance (stamped on the appliance identification plate) must be checked for correspondence to the available mains supply voltage, and the mains electric wiring should be capable of handling the oven's power rating (also indicated on the identification plate). If you have any doubts, call in a qualified technician.

NOTE: For connections to the mains power supply, never use adapters, reductions or multiple power points as these may overheat and catch fire. Do not install separate timers.

After having installed the appliance, the switched outlet must always be in an accessible position.

The electrical safety of this appliance can only be guaranteed if the cooktop is correctly and efficiently earthed, always ensure that the earthing is efficient; if you have any doubts call in a licensed electrician to check the system. The manufacturer declines all responsibility for damage resulting from an installation which has not been correctly earthed.

WARNING: If any damage occurs to the power cable during or after installation, it must be replaced immediately by a licensed electrician with a replacement cable from your Service Centre.

The cooktops can be connected to either a single phase 220-240Vac 50 Hz supply, or 2 phase 380-415Vac 50Hz.

SINGLE PHASE CONNECTION

First, a bridge connection must be made between terminals 1 and 2 (live) and between 3 and 4 (neutral). Connect the pairs to the live and neutral power supply cables. Connect the ground terminal to the ground supply cable.

TWO PHASE CONNECTION

First remove any bridge connection between terminals 1 and 2 (live). Place a bridge connection between 3 and 4 (neutral). Connect terminals 1 and 2 to the live power supply cables. Connect either terminal 3 or 4 to the neutral power supply cable. Connect the ground terminal to the ground supply cable.

The mains terminal block is located on the underside of the cooktop and the terminals are accessible by removing the terminal block cover using a small flat screwdriver.

The appliance is designed for fixed connection to the mains. During installation, an all pole disconnecter should be included inside the supply circuit with a contact opening of at least 3mm (rated 32A, delay functioning type). The power supply cord must not touch against any hot surfaces and must be placed so that its temperature does not exceed 75 °C at any point along its length.

IMPORTANT: The appliance must NOT be connected to the mains supply by means of a 10A, 15A or 20A plug and socket.

The maximum current drawn in a single phase installation is 32A, and 2x16A for a two phase installation. Only use cables Tmax 90C types H05RN-F, H07RN-F, H05RR-F, H07RR-F etc.

INSTALLATION



The adjacent furniture must be able to withstand a minimum temperature rise of 100°C above the ambient temperature of the room it is located in, during periods of use. The power supply to the appliance must be cut off before any adjustments or maintenance work is done on it. The appliance must be well ventilated (as per this manual) otherwise the appliance will overheat.

PREPARATION FOR INSTALLATION AND USE

Manufactured with best quality parts and materials, this modern, functional and practical cooktop will meet your needs in all respects. Make sure to read the manual to obtain successful results so as not to experience any problems in the future. The information given below contains rules that are necessary for correct positioning and service operations. They should be read without fail, especially by the technician who will position the appliance.

CHOOSING A LOCATION FOR THE APPLIANCE

There are several points to pay attention to when choosing a location for your cooktop. Make sure to take into account our recommendations below in order to prevent any problems and dangerous situations, which might occur later!

When choosing a location for the cooktop, attention should be paid that there are no flammable or combustible materials in the close vicinity, such as curtains, oil, cloth etc. which quickly catch fire.

Ensure a distance between the cooktop edge and rear or side walls of at least 50mm.

Furniture surrounding the cooktop must be made of materials resistant to temperatures above 100°C.

Required changes to wall cabinets and exhaust fans above a built-in cooktop as well as minimum heights from the oven board are shown in Figure 1. Accordingly, the exhaust fan should be at a minimum height of 65 cm from the cooktop. If there is no exhaust fan the height should not be less than 70 cm.

□

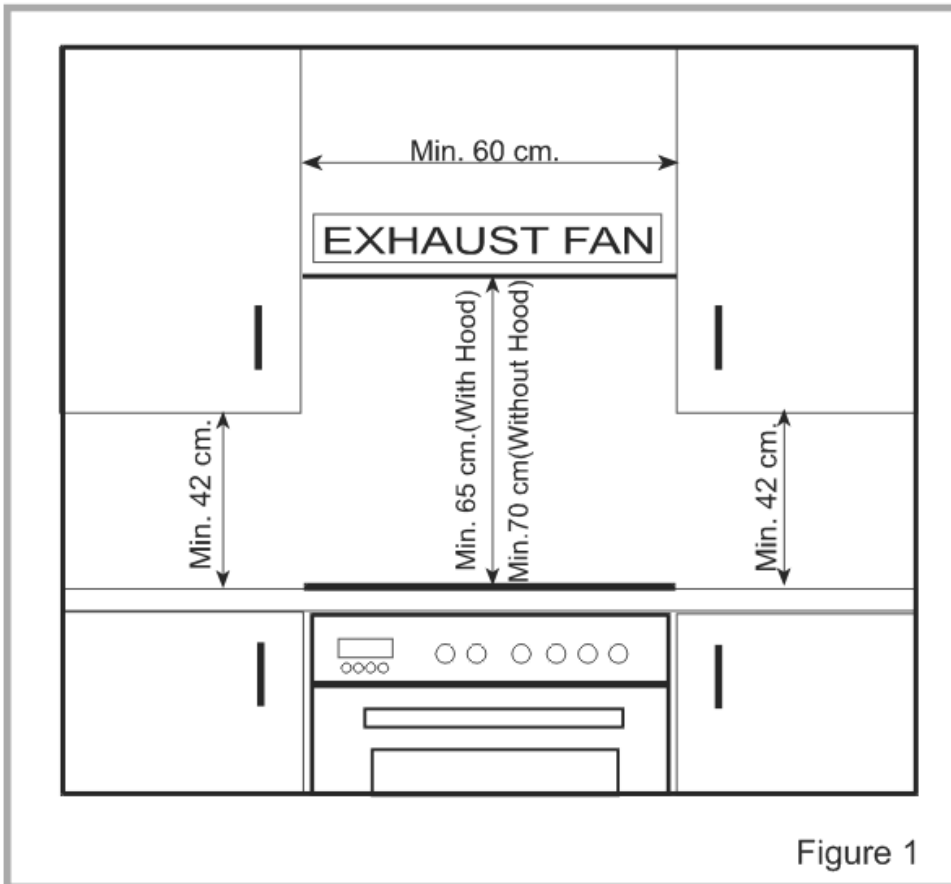
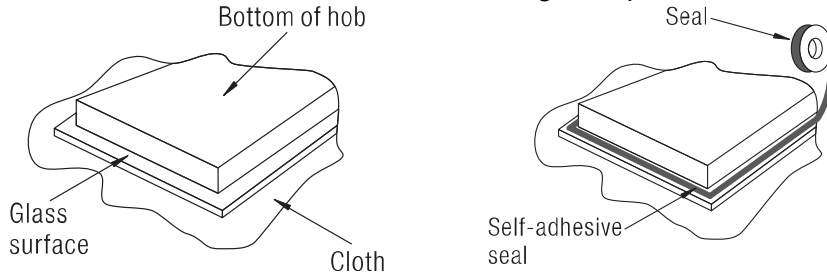

Figure 1

INSTALLATION OF BUILT IN COOKTOP

In order to prevent leakage of any liquids on the work bench and fix the appliance to the bench, a special sealing tape is supplied together with your oven. Place the cooktop glass down on a clean cloth on a stable flat surface & apply this seal around the bottom edge of the cooktop (see below). Remove the backing from the sealing tape and then place the appliance in position. If the sealing tape is not enough to fully seal the appliance to the bench, use a small bead of clear high temperature resistant silicone sealant.



This appliance can be installed into a workbench 30-40mm thick. When cutting the hole in the work bench, keep in mind the correct space and ventilation which are shown in the diagrams below.

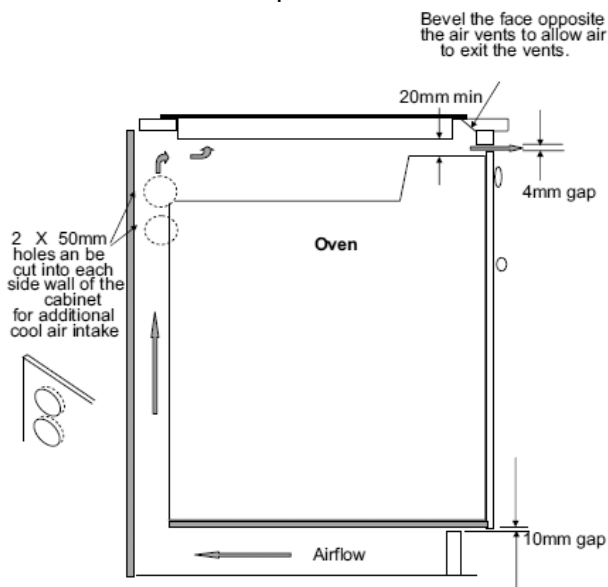

Minimum clearances and ventilation requirements for cooktops installed above an oven

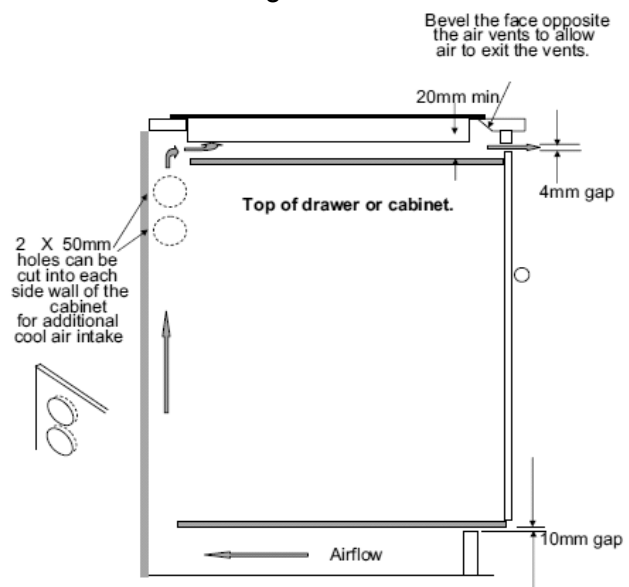

Minimum clearances and ventilation requirements for cooktops installed above a cabinet or drawers

A board must be placed a minimum of 20mm below the cooktop that prevents anyone from touching the underside of the cooktop. Take care that there is adequate ventilation for air exchange to the inductive elements (at least 20mm).

NOTE: INDUCTIVE COOKTOPS GENERATE A LOT OF HEAT INTERNALLY WHEN IN OPERATION. THE BOTTOM OF THE APPLIANCE MUST HAVE A CLEAR PATHWAY TO VENT THIS HEAT OUT VIA THE BOTTOM FANS TO THE OPEN AIR IN ORDER TO KEEP ITSELF COOL. FAILING TO PROVIDE ADEQUATE VENTILLATION WILL DAMAGE THE APPLIANCE AND VOID YOUR WARRANTY. THE ABOVE DIMENSIONS SHOULD BE CONSIDERED THE MINIMUM VENTILLATION REQUIRED.

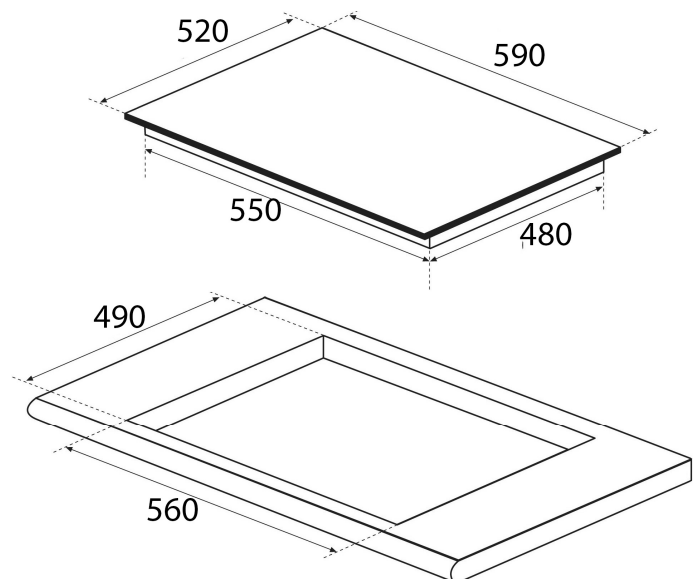

TROUBLESHOOTING AND ERROR CODES

The appliance or a cooking zone doesn't start:

- The electrical connection to the power is faulty – Call an electrician.
- A fuse has blown – Check fuse box.
- The Key Lock function is active – reset as per the manual.
- The control panel buttons are coated in grease or water – clean as per the manual.
- An object is covering a control button – in general only one button can be pressed at a time, so remove object to free-up buttons.

The control panel displays a “U” in one of the Cooking Zone Power LED displays:

- There is no cookware on the cooking zone – replace cookware on cooking zone.
- Cookware cannot be used with induction cooktops - replace cookware.
- The size of the base of the cookware is too small - replace cookware.

The appliance or a cooking zone cuts out:

- A fuse has blown – Check fuse box.
- A cooking zone has run unattended for a long period of time so has turned off – reset.
- A control panel button has been pressed or covered – remove object and reset.
- Cookware is empty and base has overheated – turn off appliance, let cool then restart with cookware refilled.

The control panel LED displays show “A” or “Er03”:

- An object or liquid is covering some or all of the buttons – remove object or carefully clean the liquid away from the control panel.

The control panel LED displays show “E2” or “EH”:

- The appliance has overheated – remove cookware from top and allow to cool.

The control panel LED displays show “E3”:

- The cookware has been detected, but is not suitable – remove cookware and replace.

The control panel LED displays show “E6”:

- The appliance has detected that the electrical input is not suitable – check power supply.

The control panel LED displays show “E8”:

- The appliance has detected that the ventilation at the bottom of the appliance has become blocked – check vents are clear & clean, and that fans can be heard starting up periodically.

The control panel LED displays show “EC” or “E4”:

- There is a problem with the internal software – reset software (see next page).

If the problem persists, please contact Blanco using the contact details at the end of the manual.

RESETTING THE INTERNAL SOFTWARE SYSTEM

If the error codes EC or E4 appear, please do the following:

- a) Remove all cookware from the cooktop. Have an inductive pot or pan with a bottom diameter of at least 16cm close by for use during the procedure.
- b) Remove the appliance from the power supply for a few minutes, by turning the circuit breaker off or removing the fuse.
- c) Reconnect the appliance to the power supply. There is now 2 minutes to start the next step, otherwise repeat the above.
- d) STEP 1: Without pressing the On/off power touch control, press the Decrease Power/Time touch control and keep touching with one finger. While still touching the Decrease Power/Time touch control, quickly press each Timer/Zone Power touch control (less than 2 seconds) in succession, starting from RH, to LHR and ending at LHF. If a double beep is heard, a mistake has been made & the process needs to start from the beginning. If not, remove all fingers from the control panel and press Decrease Power/Time touch control and Increase Power/Time touch control simultaneously for a few seconds until flashing "E" symbols appear. Wait until the symbols stop flashing and change to "C" on each LED display. This means the old software has been purged from the appliance.
- e) STEP 2: Select a cooking zone by pressing the Timer/Zone Power touch control. Place the pot or pan centrally in the cooking zone. Wait for the LED display to change from "C" to a "-". Repeat for every cooking zone. Do not use multiple pots or pans, or change during the process. Once all the cooking zone LED displays are showing "-", the process is finished.
- f) The appliance should now turn off and on again correctly. If the error codes persist, please contact the Blanco Service Department.

**We appreciate your feedback.
Please review our products on [www. blanco-australia.com](http://www.blanco-australia.com)**

AUSTRALIAN & NEW ZEALAND PRODUCT WARRANTY STATEMENT OF STANDARD WARRANTY CONDITIONS

AUSTRALIAN CUSTOMERS

Our goods come with guarantees that cannot be excluded under the Australian Consumer Law. You are entitled to a replacement or refund for a major failure and for compensation for any other reasonably foreseeable loss or damage. You are also entitled to have the goods repaired or replaced if the goods fail to be of acceptable quality and the failure does not amount to a major failure.

NEW ZEALAND CUSTOMERS

Nothing herein contained shall be construed in any way as excluding or limiting your rights under the Consumer Guarantee Act 1993.

OUR WARRANTY

This product is also covered by the manufacturer's warranty set out in this document (**Our Warranty**).

Our Warranty is for a period of **twenty four (24) months** from the date of purchase and for dishwasher & refrigeration appliances will have an additional **thirty six (36) months** after the first **twenty four (24) months** on the wash motor for dishwashers & on the Sealed System (**PARTS only** Compressor & condenser etc) for refrigeration appliances. The labour cost to replace these parts is the responsibility of the customer.

This is in addition to (and does not exclude, restrict or modify) any rights or remedies to which you may already be entitled under the Australian consumer Law or the New Zealand Consumer Guarantee Act 1993 relating to this product.

Our Warranty (which is subject to the conditions below) covers rectification free of charge of any fault arising from defective materials or components, or faulty workmanship. The product will be repaired or replaced at the option of Blanco, and all costs of installation, removal, cartage, freight travelling expenses and insurance are to be paid by the customer.

Our Warranty is subject to the following conditions:

1. That the purchaser contact Blanco prior to any product repair.
2. That the purchaser carefully follows all instructions provided with the product and complies with all relevant electrical & plumbing regulations in their State when installing the product.
3. That the purchaser carefully follows the instructions provided in the owner's handbook relating to the proper use and care of the product and does not use the product for any purpose other than the DOMESTIC use for which it has been designed. If the appliance is used in commercial applications or for rental purposes, **Our Warranty** is limited to a warranty of **Twelve (12) months** covering all parts with **Three (3) months** on any labour cost of service or repair.

SERVICE AREA

The provision of service under **Our Warranty** is limited by the boundary / territory area of the nearest service centre. Travelling cost incurred for service outside this area is not covered by Our Warranty and service will incur commercial cost to be paid by the customer regulated by the number of kilometres travelled beyond the service area. These costs will be disclosed to you for acceptance by you prior to your claim being processed.

Microwave ovens must be returned to your nearest Authorised Service Centre for repair as they are a carry in serviceable appliance.

WHAT IS COVERED: By Our Warranty

During the warranty period, Blanco or its authorised Service Centre will at no extra charge, if your appliance is readily accessible without the need of special equipment and subject to the terms and conditions of this warranty, repair or replace any parts which it considers defective.

WHAT IS NOT COVERED: By Our Warranty

1. Products installed damaged or incomplete or not in compliance with the relevant electrical & plumbing regulations in their State.
2. Normal wear and tear e.g. cleaning, light globes, filters etc.
3. Failure resulting from power surges and electrical storms.
4. Insect or vermin infestation.
5. Unauthorised repairs or use of non genuine Blanco parts.
6. Any failure caused by the product not being used in accordance with the instruction and the installation manual provided with the product.
7. Misuse or abuse, including failure to properly maintain or service.
8. The clearing of blockages in pumps and hoses.
9. Damage which occurs during delivery or installation.
10. Claims to product surface coating due to liquid or solid spill-overs, accidental damage or damage caused from cleaning products not recommended by Blanco.

HOW TO CLAIM OUR WARRANTY

You will need to contact Blanco in Australia or New Zealand by using the contact details below.

IN AUSTRALIA

Blanco is distributed by Shriro Australia Pty Ltd

Locked Bag 5002, Kingsgrove, NSW, 2208

Phone: 1300 795 572 Fax: 1800 686 413

Email: customer@shriro.com.au

Web: <http://www.blanco-australia.com/>

IN NEW ZEALAND

Blanco is distributed by Monaco Corporation
(Member of Shriro Australia Pty Ltd)

PO Box 4399, Shortland St, Auckland, 1140

Phone: 09 415 6000 Fax: 09 415 7060

Email: service@shriro.com.au

Web: <http://www.blanco-australia.com/>

Note: Please complete the following details when you have unpacked the product and staple this card with the purchase invoice or sales docket.

Model No.....

Serial No.....

Date of Purchase.....

Retailer.....