

USER MANUAL

PSP632, DSP635, GSP625, GSP627



600mm SLOT-IN FREESTANDING COOKER



Westinghouse

CONTENTS

CONGRATULATIONS

Congratulations and thank you for choosing our Product. We are sure you will find your new appliance a pleasure to use and a great asset to your cooking. Before you use the appliance, we recommend that you read through the whole user manual which provides a description of the product and its functions.

To avoid the risks that are always present when you use a gas appliance, it is important that the appliance is installed correctly and that you read the safety instructions carefully to avoid misuse and hazards. For future reference, please store this booklet in a safe place.

RECORD MODEL AND SERIAL NUMBER HERE:

Model:

Serial number:

Please read the user manual carefully and store in a handy place for later reference. The symbols you will see in this booklet have these meanings:



WARNING

This symbol indicates information concerning your personal safety



CAUTION

This symbol indicates information on how to avoid damaging the appliance



TIPS & INFORMATION

This symbol indicates tips and information about use of the appliance



ENVIRONMENTAL TIPS

This symbol indicates tips and information about economical and ecological use of the appliance

Meanings of symbols used in this manual are shown below:



This symbol indicates never to do this



This symbol indicates always do this

CONTENTS

Important safety instructions	3
Description of your appliance	4
Before operating your appliance for the first time.	5
Installing your oven accessories	5
Using the hotplate.	7
Using the grill	8
Guide to better grilling	9
Using the timer	10
Using the oven	12
Dealing with cooking problems	15
Electronic burner control (models 625 and 627 only)	16
Cleaning your appliance.	17
Cleaning your oven accessories.	18
Solving problems	19
Installing the appliance	20
Wiring requirements.	22
Connecting to services and commissioning.	22
Testing the operation of the gas cooker.	25
Warranty.	27



TIPS & INFORMATION

IMPORTANT – CHECK FOR ANY DAMAGE OR MARKS.

If you find the appliance is damaged or marked, you must report it within 7 days if you wish to claim for damage/ marks under the manufacturer's warranty. This does not affect your statutory rights.



ENVIRONMENTAL TIPS

Information on disposal for users

- Most of the packing materials are recyclable. Please dispose of those materials through your local recycling depot or by placing them in appropriate collection containers.
- If you wish to discard this product, please contact your local authorities and ask for the correct method of disposal.

IMPORTANT SAFETY INSTRUCTIONS

GENERAL WARNINGS

- This appliance is not intended for use by persons (including children) with reduced physical, sensory or mental capabilities, or lack of experience and knowledge, unless they have been given supervision or instruction concerning use of the appliance by a person responsible for their safety. Children should be supervised to ensure that they do not play with the appliance.
- During use, this appliance becomes hot. Care should be taken to avoid touching hot surfaces, e.g. oven door, heating elements or internal surfaces of the oven.
- This appliance must not be used as a space heater.
- In order to avoid a fire, the appliance must be kept clean and vents kept unobstructed.
- Do not spray aerosols in the vicinity of the appliance during operation.
- Do not store flammable materials in or under the appliance, e.g. Aerosols.
- Accessible parts will become hot when in use. To avoid burns and scalds children should be kept away.
- Do not line the bottom of the oven or grill with foil or cookware.
- Always use gloves when handling hot items inside grill or oven.
- Where this appliance is installed in marine craft or in caravans, it shall not be used as a space heater.
- Do not use harsh abrasive cleaners or sharp metal scrapers to clean the oven door glass since they can scratch the surface, which may result in shattering of the glass.

GRILL

- Always turn the grill off immediately after use as fat left there may catch fire.
- Always keep the grill dish clean as any fat left may catch fire.
- Do not leave the grill on unattended.
- To avoid a fire, ensure that grill trays and fittings are always inserted into the appliance in accordance with the instructions.
- Do not place thick portions of food under the grill. Foods may curl, catch and ignite.
- Accessible parts may become hot when grill is in use. Children should be kept away.

OVEN

- During use the appliance becomes hot. Care should be taken to avoid touching the hot surfaces inside the oven.
- Switch the appliance off before removing the oven light glass for globe replacement.
- To avoid an accident, ensure that oven shelves and fittings are always inserted into the appliance in accordance with the instructions.
- Do not use the door as a shelf.
- Do not push down on the open oven door.

INSTALLATION, CLEANING AND SERVICING

- An authorised person must install this appliance. (Certificate of Compliance to be retained)
- Before using the appliance, ensure that all packing materials are removed from the appliance.
- In order to avoid any potential hazard, the enclosed installation instructions must be followed.
- Ensure that all specified appliance vents, openings and airspaces are not blocked.
- Where the appliance is built into a cabinet, the cabinet material must be capable of withstanding 85°C
- Only authorised personnel should carry out servicing. (Certificate of Compliance to be retained)
- Always ensure the appliance is switched off before cleaning or replacing parts.
- Do not use steam cleaners, as this may cause moisture build up.
- Always clean the appliance immediately after any food spillage.
- To maintain safe operation, it is recommended that the product be inspected every five years by an authorised serviceperson.
- If rigid gas pipe is used for installation it should include sufficient loops to allow the appliance to be removed from installed position without the need to disconnect the piping.

THIS APPLIANCE MUST BE EARTHED.

- For appliances supplied with a supply cord, if the supply cord is damaged, it must be replaced by the Manufacturer or its service agent or similarly qualified person in order to avoid a hazard.

DESCRIPTION

DESCRIPTION OF YOUR APPLIANCE

MODEL PSP632

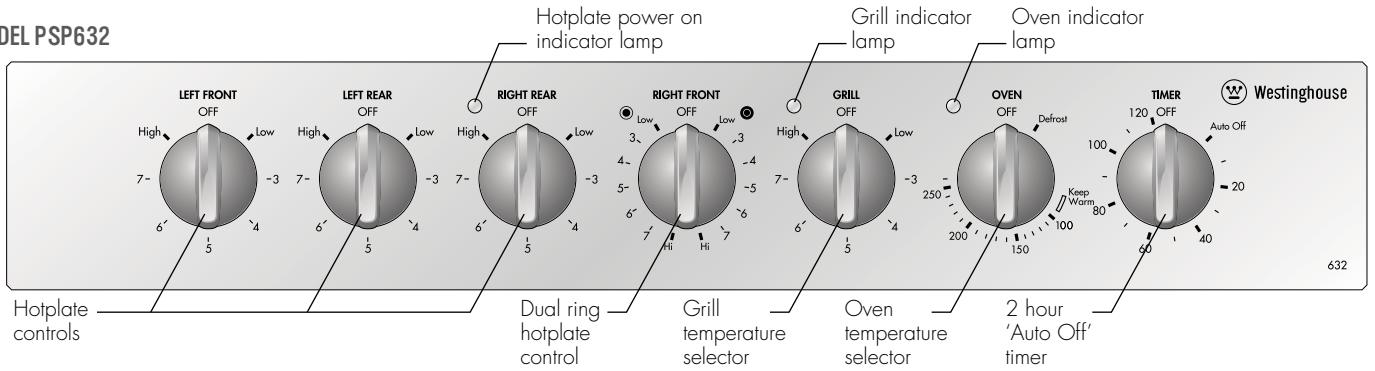

MODEL PSP632

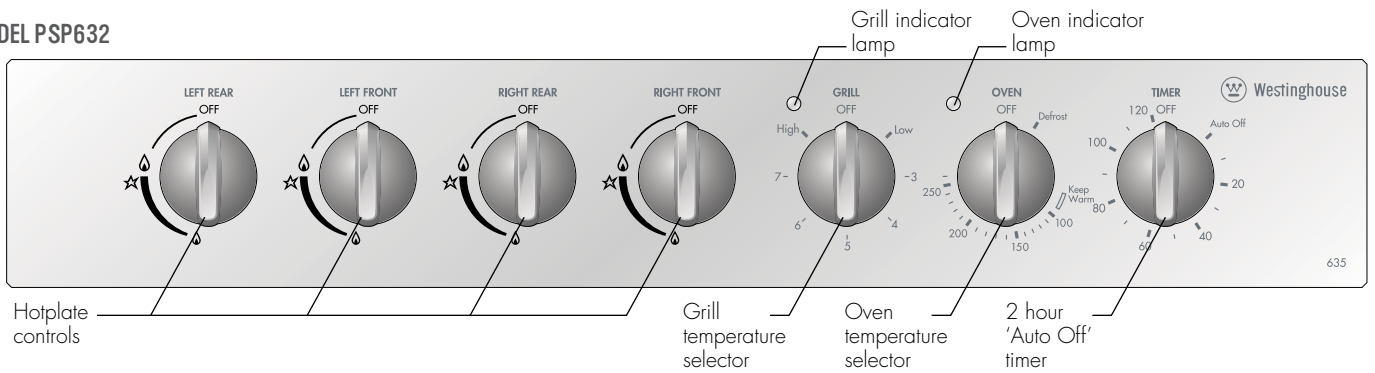

MODEL GSP625

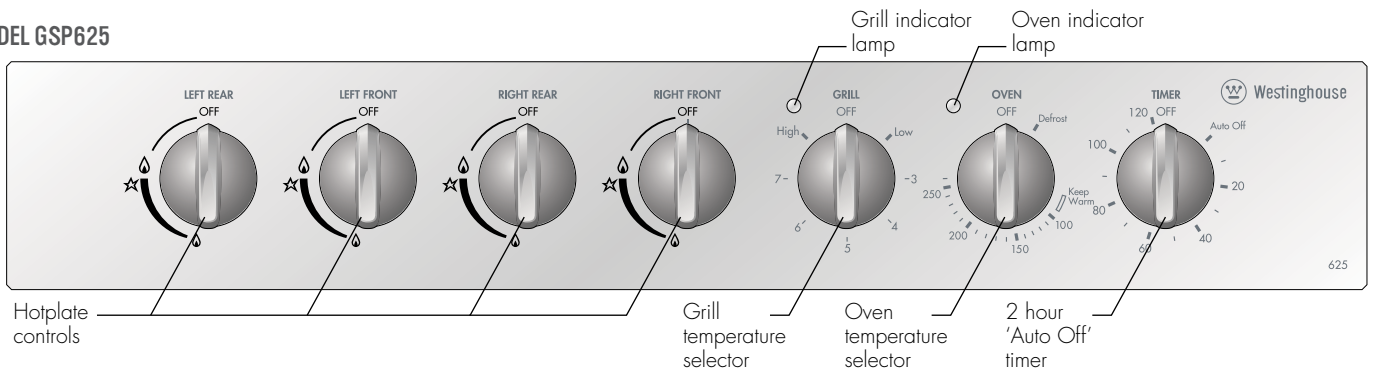

MODEL GSP627

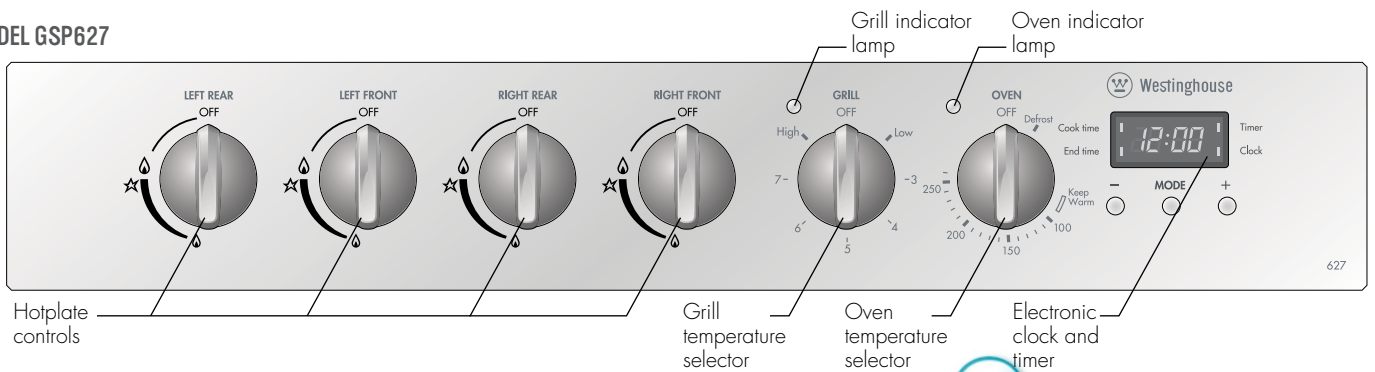

BEFORE OPERATING YOUR APPLIANCE FOR THE FIRST TIME

SETTING THE TIME

If you have purchased a model fitted with an electronic timer, you **must** set the time of day before you can operate your appliance.

3 Button Electronic Clock

- After the appliance has been electrically connected "12:00" will be displayed and the "clock" indicator will flash.



- To set the time of day, press the - or + buttons. 5 seconds after the last change, the "clock" indicator will disappear, confirming the time has been set.

NOTE: The clock has a 24-hour display.

PREPARING YOUR APPLIANCE FOR THE FIRST TIME

- Please remove all internal boxes and bags from the oven before operation.
- Please wipe out the oven interior prior to operation with warm soapy water and polish dry with a soft clean cloth. Do not close the oven door until the oven is completely dry.
- New appliances can have an odour during first operation. It is recommended to 'run in' your oven before you cook for the first time. Run the oven at 180°C for 2-4 hours and ensure the room is well ventilated.
- DO NOT line the oven with foil. It will damage the enamel.
- If your appliance is fitted with a 2-hour "Auto Off" timer, make sure it is set to the "Off" marker for manual operation. See image.

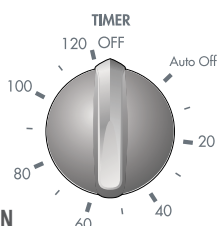

COOLING/VENTING FAN

Your appliance is fitted with a cooling fan. This prevents your kitchen cabinet from overheating and reduces the condensation inside the oven. It will operate whenever you are using your oven or grill and will blow warm air across the top of the oven door. The cooling fan may continue to operate after the appliance is turned off. It will switch off by itself once the oven is cool.

INSTALLING YOUR OVEN ACCESSORIES

SIDE RACKS

The side racks that come with your oven are all fitted the same way and can be attached to either side of your oven.

- Insert the largest peg into rear access hole provided.
- Then locate the front peg into the front access hole and push in firmly.

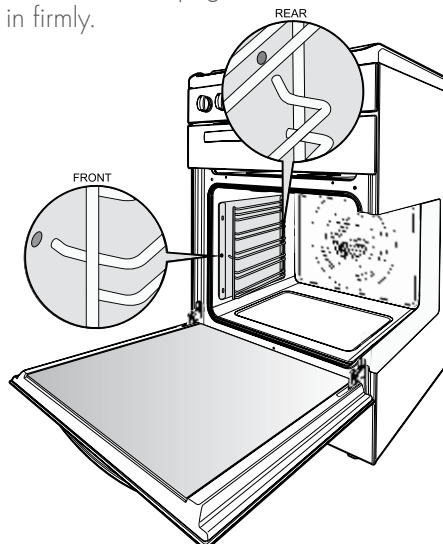

SHELVES AND TRAYS

The shelves are designed so that they have maximum travel but cannot be accidentally pulled right out. The trays are designed the same way and fit straight into the side racks.

- Locate the rear edge of the shelf/tray in between 2 guide rails of the side rack – see diagram. Ensure the same rail positions on both sides of the oven are being engaged.
- With the front edge raised, begin to slide the shelf into the oven.
- Once the detents have passed the front edge of the side rack, the shelf can be pushed completely in.
- When fully inserted the shelf/tray should not interfere with the closed oven door.
- Remove extra trays and dishes before roasting or baking.

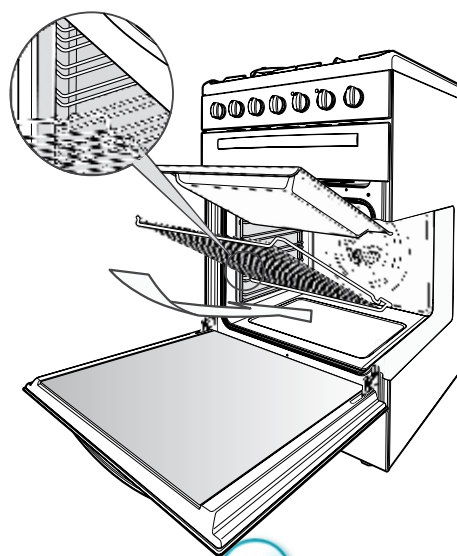

INSTALLATION

GRILL TRAY

To insert the grill tray, fully open the drawer and position the tray so that the slots on the outer edges fit over the tabs on the slides.

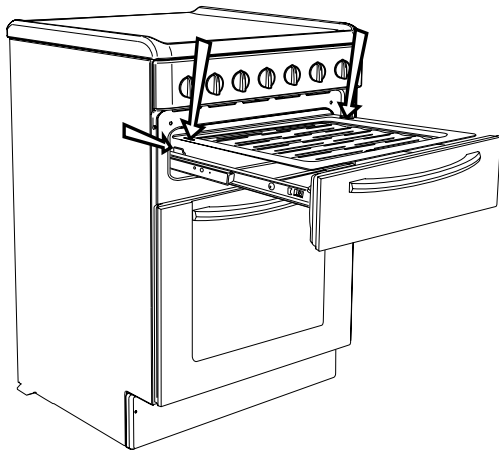

Place the grill tray insert into the grill tray.

BURNER CROWNS AND CAPS

- The burner crown must be fitted correctly into the burner cup or damage will occur during operation.
- To do this, ensure that the 2 ribs on either side of the spark plug hole are positioned into the 2 slots on the burner cup (see diagram).
- The burner cap is simply positioned over the top of the burner crown.

NOTE: When the burner is correctly fitted it will sit level on the hob.

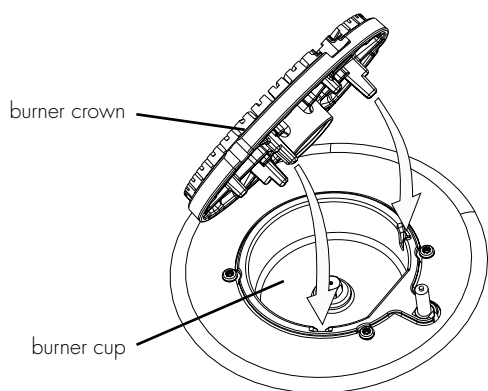

TRIVETS

- The rubber feet on the trivets locate into the recesses on the hob.
- Take care when placing the trivets as dropping them may damage the hob or trivet.
- The wok trivet sits on top of the base trivet above the wok burner.

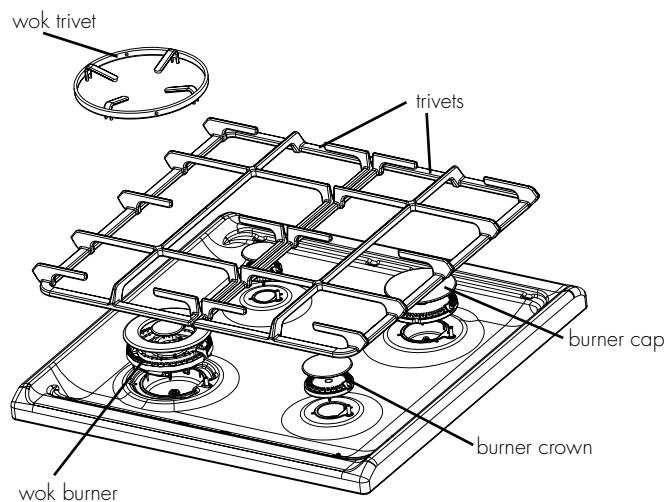

USING THE HOTPLATE

USING THE HOTPLATE

HOTPLATE DOS AND DON'TS

- ⊘ Do not place heat resistant mats, wire mats or aluminium foil under pots and pans.
- ⊘ Do not allow pots and pans to boil dry, as damage to both pan and hotplate may result.
- ⊘ Do not use the hotplate as extra bench space or as a cutting board.
- ⊘ Do not allow children on or near the cooktop at any time.
- ⊘ Do not allow large cookware to overhang the hotplate onto the adjacent benchtop. This will cause scorching to the benchtop surface.
- ⊘ Do not use round bottom woks or similar utensils which could lead to overheating of the hotplates and possible damage to the cooking surface.
- ⊙ Use the stored heat in the hotplate by turning the control to off before the final few minutes of cooking.
- ⊘ Do not slide pans across the surface of the ceramic glass as it could result in scratching of the surface.

CERAMIC HOTPLATES

The cooktop is made from ceramic glass, a tough, durable material that withstands heating and cooling without breaking. It is strong enough to hold the heaviest utensils. However, it must be remembered that as it is GLASS, it may break. Treat it accordingly!

Should you have any questions about the glass in your new appliance, please contact the service centre by dialling 13 13 49.

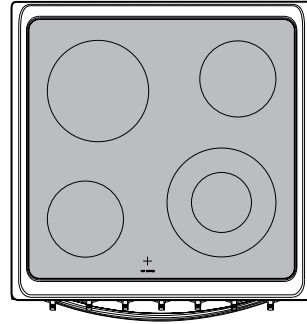

The heating elements are concealed under the smooth glass surface which has a pattern to show the location of the elements. When cooking, turn the control to the required setting.

The ceramic cooktop glass will retain heat for a period of time after the control is turned off. This will be indicated by the hot surface warning light which will continue to glow until the temperature drops below 60°C.

NOTE: If the ceramic glass is cracked switch off the appliance to avoid the possibility of electric shock.

- Use pans with smooth, clean and dry bottoms to avoid scratching or burning residue into the glass.
- Ensure the pan bottom is the same size as the working element.
- We do not recommend ceramic glass pans because they do not conduct heat well.
- Stainless steel or enamelled saucepans are best.
- Do not use pans with copper or aluminium bottoms because they can leave traces which are difficult to remove from the glass.
- If buying new utensils select enamelled steel pans with 2-3mm thick bottoms or stainless steel pans with sandwich bottoms 4-6mm thick. The pan bottom should be flat, or preferably, slightly concave at room temperature so that it lies flat on the glass surface when hot.

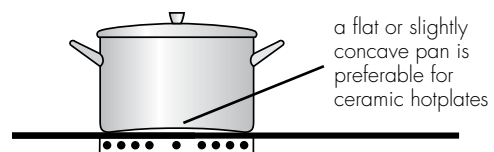

USING THE GRILL

GAS HOTPLATES

Operation

- To ignite, push knob in and turn anti-clockwise to the ignition symbol ★.
- Sparks are sent to all burners.
- Release knob once burner has ignited and adjust the flame.

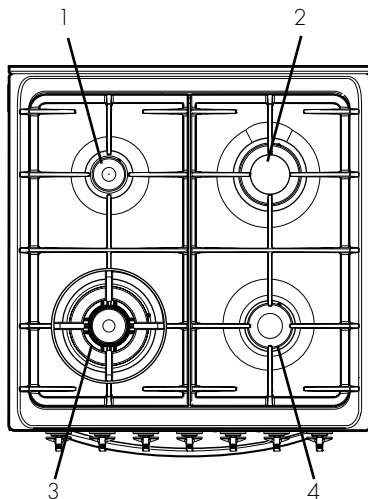

1 Low heat burner (5.1 MJ/h)

Used for simmering and for use with small cookware items.

2 High heat burner (12.7 MJ/h)

Used for fast heating with large size cookware items.

3 Intense heat wok burner (14.4 MJ/h)

Used for very fast heating with woks and other large size cookware items. Use wok support provided when cooking with a wok.

4 Medium heat burner (9.0 MJ/h)

Used for normal cooking and simmering with mid size cookware items.

To conserve gas, place the pan centrally over the burner and adjust the flame so that it does not go past the edge of the cookware.

NOTE: In the absence of electrical power, carry out the ignition directly to the burner with a hand held ignition source.

USING THE GRILL

WHAT IS GRILLING?

- The grill directs heat from the electric element in the grill compartment onto the food.

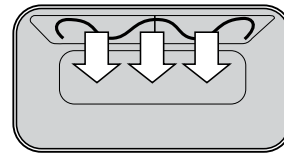

- This way of cooking traps the juices inside the food and increases the flavour.
- Grilling is suitable for tender cuts of meat, steak, chops, sausages, fish and other foods which cook quickly.

i TIPS & INFORMATION

ALWAYS CLEAN THE GRILL TRAY AND GRILL TRAY INSERT AFTER EVERY USE. EXCESSIVE FAT BUILD UP MAY CAUSE A FIRE.

IT IS BEST FOR YOUR APPLIANCE WHEN GRILLING IF THE GRILL DRAWER IS APPROXIMATELY TWO FINGER WIDTHS AJAR.

As a method of cooking, grilling can be used to:

- Enhance the flavours of vegetables, fish, poultry and meat.
- Seal the surface of the food and retain the natural juices.

This table shows how to grill different types of meat:

Beef	You can use tenderloin, rump, sirloin. Brush with oil or melted butter, especially if the meat is very lean.
Lamb	You can use loin chops, shortloin chops, chump chops, and forequarter chops. Remove skin or cut at intervals to stop curling. Brush with oil or melted butter.
Sausages	Prick sausages to stop skin from bursting.
Poultry	Divide into serving pieces. Brush with oil.
Fish	Brush with oil or melted butter and lemon juice.
Bacon	Remove rind. Grill flat.

GUIDE TO BETTER GRILLING

No definite times can be given for grilling because this depends on your own taste and the size of the food. These times should only be used as a guide and remember to turn the food over half way through the cooking process.

Steak	15 - 20 minutes
Chops	20 - 30 minutes
Fish	8 - 10 minutes
Bacon	4 - 5 minutes

For better grilling results, follow these easy instructions:

1. Preheat the grill for at least 3 minutes to obtain best results. This will help to seal the natural juices.
2. Choose only prime cuts of meat or fish. If the cut is less than 5mm thick it will dry out. If the cut is more than 40mm thick, the outside may burn whilst the inside remains raw.
3. Do not place aluminium foil under the food as this prevents fats and oils from draining away, which could result in a fire.
4. Baste the food during cooking with butter, olive oil or marinade. Grilled food is better if marinated before cooking.
5. Use tongs to turn food as a fork pierces the surface and will let juices escape.
6. Set the height of the grill tray insert to the most suitable height.
 - The grill insert can be used on both sides to provide two different grill heights
 - Thinner pieces of food should be nearer the element and thicker pieces should be 10mm away.

WARNING

SAFETY WARNINGS ABOUT THE GRILL

- ⊘ Do not cook food on the bottom of the grill compartment. Always use the grill dish and grill dish insert.
- ⊘ Do not place foil under the food on the grill dish insert, as this prevents fats and oils running away and may cause a fire.
- ✔ Always use the grill parts according to instructions.
- ⊘ Do not put thick pieces of food too near the element. They may curl and catch fire.
- ✔ Always turn the grill off immediately after cooking. Left-over fat may cause a fire.
- ✔ Always clean the grill dish and insert after use. Fat build up may cause a fire.
- ⊘ Do not let children play with the grill.
- ⊘ Do not let children use the grill without adult supervision.
- ⊘ Do not leave the grill unattended when on.
- ✔ Be careful not to touch hot surfaces.
- ⊘ Do not spray aerosols near the grill, when it is turned on.
- ⊘ Do not keep flammable materials in or near the grill, eg chemicals, aerosols, etc.

USING THE TIMER

USING THE TIMER

USING THE 2-HOUR TIMER

Manual operation

The timer needs to be set at the "OFF" marker for the oven to be used manually.

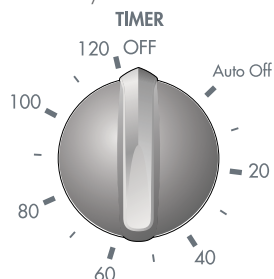

Automatic operation

The 2-hour timer features an automatic oven "cut-off". This means that a cooking period of up to 120 minutes can be set.

1. Set the Oven Temperature Control Knob to the required temperature.
2. Turn the cut-off timer to the required number of minutes.
NOTE: For timer settings of less than 20 minutes, turn the knob past 20 minutes, and then go back to the required number of minutes. This is to ensure that the timer's bell ringer is correctly set.
3. When the timer returns to the "Auto Off" position, it will give a short ring and the oven element will be switched off. Although the oven element is off, the oven light, the cooling/venting fan and the oven fan will remain on whilst the Timer is in "Auto Off" mode. They will stay on until both the Timer and the Oven knobs are moved to the "Off" position.

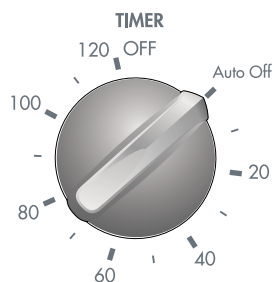

4. The oven will not operate again until you turn the timer back to the "OFF" marker. This will set the timer to manual mode.

NOTE: It is not recommended to use this timer for short durations, e.g. boiling eggs.

3 BUTTON PROGRAMMABLE TIMER

General features

Your 3 button programmable timer has the following features:



- Timer – your 3 button programmable timer allows you to set a countdown time that will beep when the set time has elapsed.
- Cooking duration – You can set a cooking duration. A timer will count down the preset cooking time, beep when the time has elapsed and turn the oven off.
- End cooking time – you can set a cooking finish time. A timer will count down the preset cooking time, beep when the finish time has been reached and turn the oven off.
- Delayed start cooking time – You can combine the cooking time and stop cooking time to switch the oven on and off at a specific time during the day.

NOTE: Your 3 button programmable timer only operates with your main oven.

Setting the time of day

You must set the time of day before you can operate your appliance. When power is supplied to your oven "12.00" will be displayed and the "clock" indicator will flash.

1. To set the time of day in hours and minutes, press the – or + buttons. 5 seconds after the last change, the "clock" indicator will disappear, confirming the time has been set.

NOTE: The clock has a 24-hour display.

Setting the timer

1. Press the "mode" button until the "timer" indicator begins flashing.
2. Set the countdown time you want by using the – and + buttons. 5 seconds after the last change the "timer" indicator will stop flashing, confirming the timer has been set.
3. To stop the beeper, press any button.

Setting the cooking duration

1. Check the clock displays the correct time of day.
2. Select the desired oven function and temperature. The oven indicator light will glow and the heating source will come on.
3. Press the "mode" button until the "cook time" indicator begins flashing.
4. Set the cooking duration you want by using the – or + buttons. 5 seconds after the last change, the "cook time" indicator will stop flashing, and the time of day will be displayed.

NOTE: Do not forget to add preheating time if necessary.

Setting the cooking end time

1. Check the clock displays the correct time of day.
2. Select the desired oven function and temperature. The oven indicator light will glow and the heating source will come on.
3. Press the "mode" button until the "end time" indicator begins flashing.
4. Enter the time of day you want to finish cooking by pressing the – or + buttons. 5 seconds after the last change, the "end time" indicator will stop flashing and the current time of day will be displayed.

Setting the delayed start cooking time

1. Program the "cook time" and "end time" as described in the relevant sections. Once both the "cook time" and "end time" have been set, the "cook time" and "end time" indicators will stop flashing and the current time of day will be displayed.

To check or cancel settings

1. To check your settings, press the "mode" button until the setting you want is displayed. A red indicator light will flash next to the mode (cook time, end time etc) that is currently on display.
2. To cancel "delayed start" press the "mode" button until the indicator next to "end time" flashes. Press and hold the – button until the clock no longer reverses (you will hear a beep). If you have left the temperature and function knobs at a setting the oven will start once the "end time" indicator stops flashing.
3. To cancel "auto shut off" press the mode button until the indicator next to "cook time" flashes. Press and hold the – button until the clock no longer reverses at ("0:00" and you will hear a beep). This automatically cancels "delayed start". If you have left the temperature and function knobs at a setting, the oven will start once the "cook time" indicator stops flashing. Because you have cancelled "auto off" the oven will continue to heat until you manually turn it off.

On completion of cooking

The oven will turn off, the timer will beep and the "end time" and/or "cook time" indicators will flash.

1. Turn the function and temperature controls to the off position.
2. Press any button to stop the timer from beeping.

Switching the clock display ON and OFF

1. Press any two buttons together for 2 seconds to switch 'off' the display.
2. Press any button to switch the clock display 'on' again.

NOTE: If a timer mode is set, then it is not possible to switch the display off.

USING THE OVEN

USING THE OVEN

FAN BAKING

The temperature in the oven is controlled by a thermostat. The fan distributes the heat throughout the oven compartment. This allows:

- Baking on all shelves at the same time with little variation in browning or cooking.
- Cooking at slightly lower temperatures.
- Cooking from a cold start so there is no need to preheat the oven – this is good for casseroles and fruit cakes.
- Good cooking results for cream mixtures, rich pastries and bread but with these foods, preheating the oven for 10 to 15 minutes is required.

DEFROSTING

- Defrosting uses air that is circulated by the fan.
- You should defrost food before cooking it.
- You can also use the defrost function to raise yeast dough and dry fruit, vegetables and herbs.

CONDENSATION

Condensation fogs the oven door and happens when you are cooking large quantities of food from a cold start. You can minimise condensation by:

- keeping the amount of water used in cooking to a minimum;
- making sure that the oven door is firmly closed;
- cooking casseroles with a lid.

NOTE: If you are using water in cooking, this will turn to steam and may condense outside the oven. This is not a problem or a fault.

COOKING GUIDE

- Select the correct shelf location for food being cooked.
- The grill tray can be used in the oven as a baking dish.
- Make sure dishes will fit into the oven and remove unnecessary trays or dishes before you switch it on.
- Keep edges of baking dishes at least 40mm from the side of the oven. This allows free circulation of heat and ensures even cooking.
- Do not open the oven door more than necessary.
- Do not place foods with a lot of liquid into the oven with other foods. This will cause food to steam and not brown.
- After the oven is turned off it retains the heat for some time. Use this heat to finish custards or to dry bread.
- Do not use a lot of cooking oil when roasting. This will prevent splattering oil on the sides of the oven and the oven door. Polyunsaturated fats can leave residue which is very difficult to remove.
- When cooking things which require a high heat from below (e.g. tarts), place the cooking dish on a scone tray in the desired shelf position.
- For sponges and cakes use aluminium, bright finished or non-stick utensils.

OVEN SHELF LOCATION

Your oven has seven positions for shelves. These are numbered from 1 (the lowest shelf position) to 7 (the highest shelf position). See diagram.

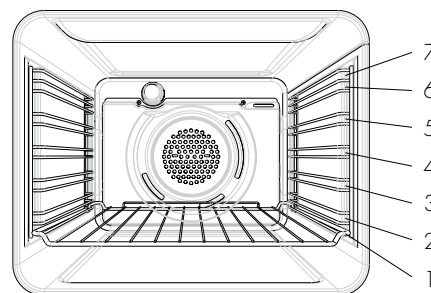

To give maximum space above and below the shelves, load them in this way:

- When cooking with 1 shelf, use position 3 or 4.
- When cooking with 2 shelves, use position 3 and 5.

Use the oven efficiently, by cooking many trays of food at the same time. For example:

- Cook 2 trays of scones, small cakes or sausage rolls.

CHOOSING THE BEST OVEN SETTINGS

The following tables are intended as a guide and experience may show some variation in cooking times necessary to meet individual requirements.

For best results when baking you must preheat your oven for 30 minutes.

Electric Oven

FOOD		TEMPERATURE IN °C	OVEN SHELF POSITION	TIME IN MINUTES
Scones	Plain or fruit	210	Any	10 - 15
Biscuits	Rolled	150	Any	10 - 15
	Spooned	180	Any	12 - 15
	Shortbread biscuits	150	Any	30 - 35
Meringues	Hard - individual	100	Any	90
	Soft - individual	165	Any	15 - 20
	Pavlova - 6 egg	100	Any	75
Cakes	Patty cakes	180	Any	15 - 20
	Sponge - 4 egg	170	Any	20 - 30
	Shallow butter cake	170	Any	30 - 40
	Rich fruit cake	130	Any	180
Pastry - shortcrust	Cornish pasties	180	Any	40 - 45
	Custard tart	190 / 170	Any	20 - 30
Pastry - choux	Cream puffs	200	Any	25 - 30
Yeast goods	Bread	200	Any	25 - 30

Gas Oven

FOOD		TEMPERATURE IN °C	OVEN SHELF POSITION*	TIME IN MINUTES
Scones	Plain or fruit	210	Any	10 - 15
Biscuits	Rolled	170	3 & 5	10 - 15
	Spooned	180	3 & 5	12 - 15
	Shortbread biscuits	150	3 & 5	30 - 35
Meringues	Hard - individual	100	Any	90
	Soft - individual	165	Any	15 - 20
	Pavlova - 6 egg	100	Any	75
Cakes	Patty cakes	180	3 & 5	15 - 20
	Sponge - 4 egg	170	3	20 - 30
	Shallow butter cake	170	3 & 5	30 - 40
	Rich fruit cake	130	3	180
Pastry - shortcrust	Cornish pasties	180 / 160	3	40 - 45
	Custard tart	190 / 170	3	20 - 30
Pastry - choux	Cream puffs	200	3 & 5	25 - 30
Yeast goods	Bread	200	Any	25 - 30

* Counting from the bottom shelf up. Refer to "oven shelf location" section for more detailed information.

ROASTING MEAT

- You can use the grill tray and grill tray insert for roasting meat in the oven.
- Place the meat in the oven and set the temperature between 180°C and 200°C. (It is recommended to wrap your meats in an oven roasting bag or foil to prevent fats and oils from splattering, making it easier to clean your oven.)
- Do not pierce the meat, as this will allow juices to escape.
- When the meat is cooked, take the roast out of the oven, wrap in aluminum foil and leave to stand for about 10 minutes. This will help retain the juices when the meat is carved.

The table shows temperatures and cooking times for different kinds of meat. These may vary depending on the thickness or bone content of the meat.

MEAT	RECOMMENDED TEMPERATURE	MINUTES PER KG
Beef	200°C Rare	35 - 40
	Medium	45 - 50
	Well done	55 - 60
Lamb	200°C Medium	40
	Well done	60
Veal	180°C Well done	60
Pork	200°C Well done	60

ROASTING POULTRY AND FISH

- Place the poultry or fish in an oven set at a moderate temperature of 180°C.
- Place a layer of foil over the fish for about three quarters of the cooking time.

The table shows temperatures and cooking times for different kinds of fish and poultry. These may vary depending on the thickness or bone content of the meat.

POULTRY & FISH	RECOMMENDED TEMPERATURE	MINUTES PER KG
Chicken	180°C	45 - 50
Duck	180 - 200°C	60 - 70
Turkey	180°C	40 - 45 (<10kg)
		35 - 40 (>10kg)
Fish	180°C	20

DEALING WITH COOKING PROBLEMS

PROBLEM	CAUSES	WHAT TO DO
Uneven cooking	Incorrect shelf position	Select shelf that puts food in centre of oven
	Oven tray too large	Try other trays or dishes
	Trays not in centre	Put trays in centre
	Air flow in oven uneven	Rotate food during cooking
	Grill tray affecting thermostat	Remove grill tray from oven on bake modes
Baked products too brown on top	Oven not preheated	Preheat the oven
	Baking tins too large for recipe	Use correct size tins
	Baking tins not evenly spaced	Stagger baking tins at least 3cm between tins and the oven walls
	Products not evenly sized or spaced on trays	Make into same size and shape and spread evenly over trays
Baked products too brown on bottom	Baking tins too large	Use correct size tins
	Baking tins are dark metal or glass	Change to shiny, light tins or lower the temperature by 10°C
	Food too low in oven	Cook one shelf higher
	Oven door opened too frequently during baking	Don't open the oven door until at least half the cooking time has passed
	Baking temperature too high	Lower the temperature
	Grill tray affecting thermostat	Remove grill tray from oven on bake modes
Cakes have a cracked thick crust	Baking temperature too high	Lower the temperature
	Food too low in oven	Cook one shelf higher
	Cake batter over mixed	Mix just long enough to combine the ingredients
	Baking tin too deep	Check size of tin and use recommended size
	Baking tins dark	Change to shiny light tins
Baked products are pale, flat and undercooked	Baking temperature too low	Raise the temperature
	Food too low in oven	Cook one shelf higher
	Baking time too short	Increase cooking time
	Incorrect baking tin size	Use correct size tin
Cakes fallen in centre	Baking temperature too low	Raise the temperature
	Baking time too short	Increase cooking time
	Proportions of ingredients incorrect for recipe	Check recipe
	Opening door too early during baking	Do not open door until the last quarter of cooking time
Roast meat and potatoes not brown in fan oven	Poor hot air circulation	Elevate food onto a rack to allow air circulation
	Grill tray affecting thermostat	Remove grill tray from oven on bake modes
Juices running out of meat		Do not pierce meat with fork, turn with tongs
Grilled meats overcooked on outside & raw in the centre		Grill at lower insert position
Grilled chops & steaks curling		Cut into fat every 2cm (¾")

ELECTRONIC BURNER CONTROL (models 625 and 627 only)

Your gas oven is fitted with an electronic controller which manages the operation of the burner and monitors the flame. This controller includes features which ensure the safe operation of your appliance and will prevent the build up of unburnt gas, should a fault occur.

It is normal for the flame to turn on and off during cooking, to maintain a stable temperature in the oven. The Thermostat Indicator Light indicates when the flame is on or igniting (indicator glows), or when the flame is off (indicator off). The burner flame can be seen by viewing through the 2 holes in the front of the burner cover.

IGNITION AND RESPONSE TO IGNITION FAILURE

The controller will attempt to ignite the flame when an oven function is selected and the Thermostat turns on (indicator light changes from off to on). The controller will make up to 2 attempts to ignite the flame, stopping if a flame is detected by the controller. If by the end of the 2 attempts a flame is not detected then the burner and ignition will be turned off and a delay of 90 seconds will be observed. During this delay the controller will not respond to the Function and Thermostat controls.

At the end of this delay, switch the Thermostat or Function Selector off and leave off for at least 5 seconds. Then switch the Thermostat and Function Selector on again to re-attempt ignition.

If the oven controls are left on when the delay ends then ignition will not be attempted until the Thermostat or Function Selector is first turned off for 5 seconds.

RESPONSE TO FLAME FAILURE

If the controller cannot detect flame due to a fault, then the controller will respond

- firstly by attempting to re-light the burner with a sequence of up to 3 attempts and
- If the re-lighting sequence is not successful the burner will be shut off.

The re-lighting sequence will include up to 3 attempts to re-light the burner, stopping if a flame is detected by the controller. If by the end of the re-lighting sequence a flame is not detected then the burner and ignition will be turned off and a delay of 90 seconds will be observed. During this delay the controller will not respond to the Function and Thermostat controls.

At the end of this delay, switch the Thermostat or Function Selector off and leave it off for at least 5 seconds. Then switch the thermostat and Function Selector on again to re-attempt ignition.

If the oven controls are left on when the delay ends then ignition will not be attempted until the Thermostat or Function Selector is first turned off for 5 seconds.

RECOGNISING A SAFETY SHUT-DOWN CONDITION

During normal cooking the Thermostat indicator light is on when the burner flame is igniting or on, and the Thermostat indicator light is off when the flame is off.

If an oven function is selected and the Thermostat light is on, but the flame is not on or attempting to ignite then the controller has invoked a safety shutdown of the burner. A 90 second delay is observed from the time the shut-down occurred before the controller will respond to the oven controls.

Once the delay period has ended the Thermostat or Function Selector must be turned off for at least 5 seconds before oven functions can resume.

POWER FAILURE

In the event of an interruption to mains power, the restoration of power will not cause the burner to ignite if the controls were left on. However the grill element will resume heating on models which do not have an electronic clock.

To resume operation of the appliance after a power interruption:

- First turn the Function Selector or Thermostat controls to the off position. The controls must remain in this position for at least 5 seconds
- If the appliance has an electronic clock then set the time of day on the electronic clock. Normal operation of the appliance may now resume.

CLEANING YOUR APPLIANCE

CAUTION

- Always make sure that the oven is electrically isolated before cleaning. This can be done via the functional switch located nearby. Do not use steam cleaners.
- Do not line the bottom of the oven or grill with foil or cookware.

ENAMEL

- Wash with warm soapy water and rinse with clean water.
 - Rub persistent stains vigorously with a nylon scourer or creamed powder cleansers.
- NOTE:** You can also use household oven enamel cleaners – follow the manufacturer's instructions carefully.
- Do not use harsh abrasive cleaners, powder cleaners, steel wool or wax polishes.

STAINLESS STEEL

All grades of stainless steel can stain, discolour or become greasy. You must clean these areas regularly by following the procedures below, if you want your appliance to look its best, perform well and have a long life.

WARNING

CARE MUST BE TAKEN WHEN WIPING EXPOSED STAINLESS STEEL EDGES... THEY CAN BE SHARP!

Your stainless steel appliance is manufactured from a mark resistant stainless steel. This special stainless steel resists marks such as fingerprints and water spots. To keep your stainless steel appliance looking it's best, you should clean it regularly. Wash with warm soapy water and rinse with clean water. Wipe with clean water and a soft cloth to remove soap residue.

NOTE: Make sure you follow the polish or brushing lines in the steel.

CAUTION

DO NOT use stainless steel cleaners, abrasive pads or other cleaners as they are likely to scratch the surface. Damage due to poor cleaning technique is not covered by your warranty.

GLASS

- Glass surfaces on doors and control panels are best cleaned immediately after soiling.
- A damp cloth may help remove baked on food deposits.
- Oven cleaners can be used to remove stubborn marks and stains.

CERAMIC HOTPLATE

- Remove all spilt food and fat with the supplied razor blade scraper, while the ceramic glass is still warm but not hot. Wipe clean with dishwashing detergent on a damp cloth.
 - If aluminium foil, plastic items or high sugar content foods are allowed to melt on the ceramic glass, clean immediately with the supplied razor blade scraper before the surface has cooled down, otherwise pitting of the surface can occur.
- NOTE:** Items with high sugar content not only include jam and fruit, but also vegetables such as peas, tomatoes and carrots.
- When the ceramic glass is cool, apply a suitable cleaner (supplied with the appliance).
 - It is important to follow the cleaner manufacturer's instructions. Remove any cleaning residue from the surface as staining of the cooktop may occur.
 - Do not use abrasive sponges or scourers, as they may scratch the surface.
 - Any pitting, staining, scratches or other surface deterioration is excluded from the warranty.
 - All stains/water marks can be removed by vigorous cleaning, using the supplied ceramic cleaner.

GAS HOTPLATE

- The trivets can be removed for cleaning by carefully lifting them from the hob.
- Clean by washing with warm soapy water.
- The burner caps and crowns are also removable for cleaning.
- If the caps, crowns and cups are heavily soiled, use a non-abrasive cleaning compound.
- Flame port blockages should be removed by using a matchstick or brush.
- Do not clean them with abrasive or caustic type cleaners, or clean them in a dishwasher.

OVEN

- Always keep your appliance clean. Ensure that fats and oils do not accumulate around elements, burners or fans.
- Always keep oven dishes, baking trays, grill trays and grill tray insert clean, as any fat deposits may catch fire.
- Always wrap your meats in foil or an oven roasting bag to minimise cleaning. Any polyunsaturated fats can leave a varnish-like residue which is very difficult to remove.

GRILL

- Always keep the grill tray and grill tray insert clean, as any fat deposits may catch fire.

CLEANING YOUR OVEN ACCESSORIES

REMOVING THE SHELVES AND GRILL TRAY FROM THE OVEN

- Slide the shelves/grill tray towards you until they reach the front stop.
- Tilt them up at the front, taking care not to spill any contents.
- Lift them clear.
- Wash the shelves, grill tray and grill tray insert in hot soapy water.
- Reverse the above steps to put the grill dish and shelves back again.
- See page 5 for more details.

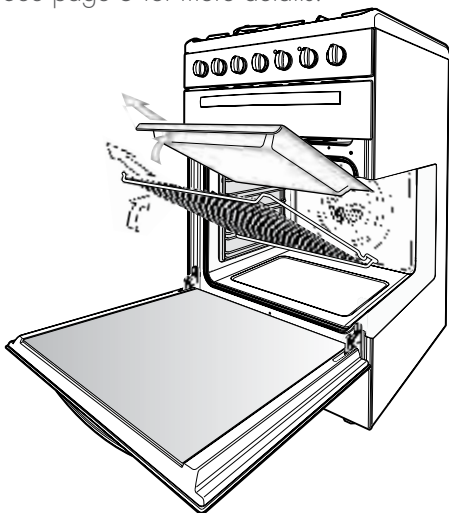

REMOVING THE SIDE RACKS

- Grasp the side rack at the front.
- While pushing the side rack to the rear of the oven, pull it firmly inwards.
- To install the side racks, see page 5.

REMOVING AND REPLACING THE OVEN LIGHT

- Turn oven light glass anticlockwise to remove it for globe replacement. A special high temperature resistant globe should be used that can be purchased from the Electrolux Customer Care Centre.

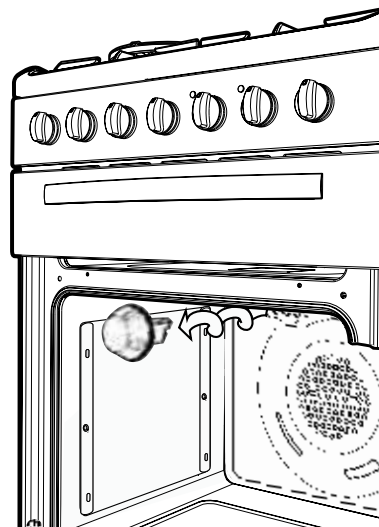

WARNING

IMPORTANT: Make sure the appliance is turned off before you remove or replace parts, to avoid the possibility of electric shock.

SOLVING PROBLEMS

SOLVING PROBLEMS

FAULTS

If there is a problem with the oven and/or grill, please:

- Check the points listed below before calling for service. It may be possible to avoid a call by fixing the problem yourself – and so continue cooking.
- For cooking problems, see page 15.

NOTE: We may charge for service even in the guarantee period if your problem is due to the causes listed below.

FURTHER INFORMATION

If you need more information, service, replacement parts or have a warranty enquiry, please contact the Customer Care Centre:

- Australia – 1300 363 640, 8.00am - 5.00pm EST Monday - Friday
- New Zealand – 09 573 2384, 8.00am - 5.00pm EST Monday - Friday

Please have the following information ready: Model, Model Number and Serial Number. This is shown on the data plate which is visible when the oven door is open.

PROBLEM	POSSIBLE CAUSES	WHAT TO DO
Oven or grill not working	Power not turned on	Switch on electricity
	Household fuse blown	Check fuses
	Controls incorrectly set	Reset controls
	Circuit breaker tripped	Check circuit breaker
	Clock not set	Set time of day on timer
NOTE: If the household fuse continues to blow, call the Electrolux Customer Care Centre.		
Oven not heating enough	Foil or trays on bottom of oven	Remove foil or trays
Light and fans on continuously	Timer not in manual mode	Set timer to manual mode
Oven not working	Timer not in manual mode	Set timer to manual mode
	Household fuse blown	Check fuses
NOTE: If the household fuse continues to blow, call the Electrolux Customer Care Centre.		
Oven light not working	Household fuse blown	Check fuses
	Circuit breaker tripped	Check circuit breaker
	Lamp blown or loose in socket	Replace or tighten lamp
NOTE: If the household fuse continues to blow, call the Electrolux Customer Care Centre.		
Cooker smoking when first used	Protective oils being removed	Turn grill on high for 30 mins and then the oven on 220°C for 1 hour
Too much condensation building up when baking	Too much water used when cooking	Reduce amount of water
		Leave oven door open after cooking
Smells when first using oven		This is normal
60 minute or 2 hour timer ring not audible	Timer not wound sufficiently	Turn timer knob past 20 minutes then turn back to required number of minutes
Gas hotplates not working	Power not turned on at appliance	Switch on electricity
	Household fuse has blown or power supply is turned off	Check fuses
	Gas is off	Check gas is supplied to the cooker
	Burner parts or spark plugs are wet or dirty	Clean and dry burners or spark plugs
Timer flashing	Power failure or interruption	Reset time of day

NOTE: In the event of a power failure the gas burners may still be lit with a handheld igniter and used. Take care to avoid letting unburnt gas flow for more than 5 seconds when attempting to light the burner.

INSTALLATION

INSTALLING THE APPLIANCE

CABINET REQUIREMENTS

This appliance has been designed to 'slot-in' to a 600mm wide gap built-in standard kitchen cabinets. As such the appliance can be installed matching the height and depth of benches and behind the kick rail of the cabinets. This allows the cooker to integrate well into contemporary kitchens. The cooker may also be installed at the end of a line of benches or with a free space on either side.

- This appliance is not supplied with a splashback.
- Ensure that all vertical surfaces (rear and sides) are non-combustible surfaces (eg ceramic tiles, sheet metal or toughened glass).
- Refer to section 5.12.1.1 of AS5601 in Australia or section 14.1.2 of NZS5261 in New Zealand for overhead clearances.

WARNING

This appliance has been tested and approved to the relevant Australian Standards. It is designed to cook food, it will get hot. Cabinet materials must be capable of withstanding 85°C. Installation into lower temperature tolerant cabinetry (eg vinyl coated) may result in deterioration of the low temperature coating by discolour or bubbling.

Electrolux Home Products cannot accept responsibility for damage caused by installation into low temperature tolerant cabinets.

RECOMMENDED CABINET DESIGN

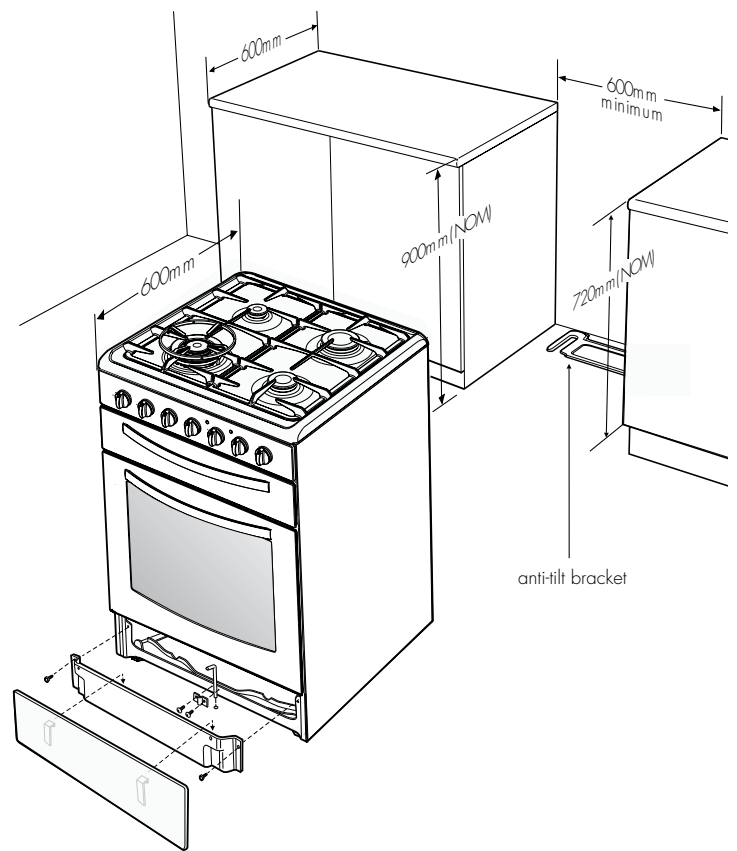

INSTALLATION SEQUENCE

1. Check that the required services are correctly positioned (see electrical and gas services requirements section and cabinet requirements section).
2. Ensure that cabinetry has correct details (see cabinet requirements section).
3. Unpack the cooker.
4. Remove the foam pack containing accessories.
5. Remove the internal pack from the oven and position shelf supports and grill trays (see page 5).
6. On gas cookers position gas burners and trivets (see page 6).

FITTING THE ANTI-TILT PLATE & STABILISING BOLT

Cooker Stability

NOTE: To ensure cooker stability, both the anti-tilt plate and stability bolt **MUST** be installed on all cookers (electric and gas).

INSTALLATION SEQUENCE

1. The cooker is delivered with the anti-tilt plate. Locate the anti-tilt plate against the rear wall. If locating between 2 cupboards, then fit the plate in the centre of the space. If locating the cooker at the end of a cupboard, then position the side of the plate 48mm from the cupboard.
NOTE: If cooker cannot be located against rear wall, move anti-tilt plate forward to suit.
2. Securely fix the anti-tilt plate to the floor with appropriate fasteners.
3. Slide the cooker back into the anti-tilt plate so that rear cover rests against the rear wall. Then check the height and level of the cooker. If required, pull the cooker back out and adjust the levelling feet as required.
4. Fasten the stability bolt bracket to the front frame with the 2 screws supplied.
5. Reposition the cooker back into the anti-tilt plate and then mark the position of the stability bolt hole.
6. Pull the cooker back out and drill the bolt location hole. Use a 6.5mm masonry or wood drill. When drilling into concrete ensure a minimum hole depth of 30mm.
7. Reposition the cooker back into the anti-tilt plate, aligning the stability bolt bracket with the 6.5mm drilled hole. Then slide the bolt through the bracket and into the hole.
8. Connect gas and electricity supply (refer to pages following).
9. Fit the kick panel bracket and kick panel onto the cooker.

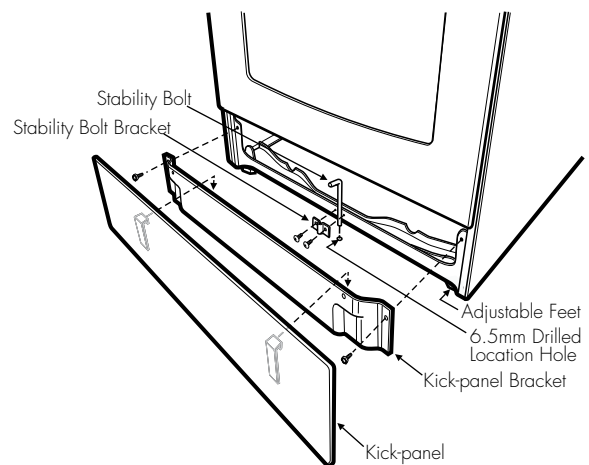
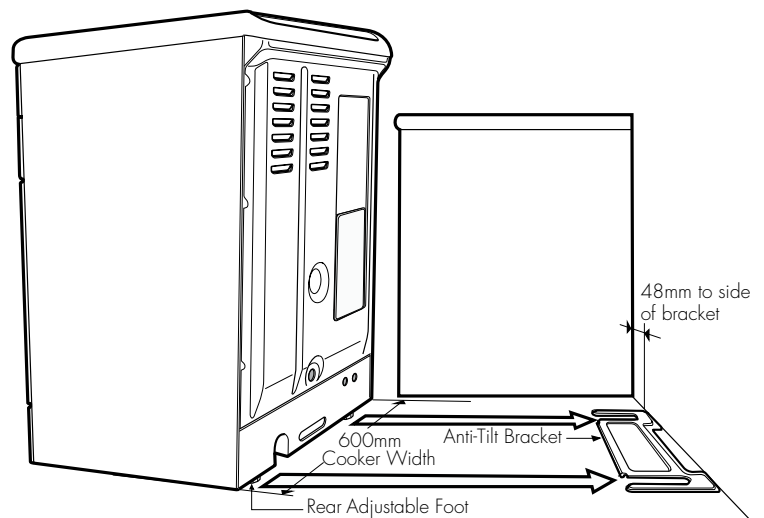

WIRING REQUIREMENTS

The cooker MUST be installed in compliance with:

- wiring connections in AS/NZS 3000 Wiring Rules
- local regulations, municipal building codes and other statutory regulations
- For New Zealand Only:

The cooking range must be connected to the supply by a supply cord fitted with the appropriately rated plug that is compatible with the socket-outlet fitted to the final sub-circuit in the fixed wiring that is intended to supply this cooking range.

Data plate	gives information about rating is located behind the bottom of the oven door
Circuit diagram	is located on the back panel of the appliance

- A functional switch MUST be provided near the appliance in an accessible position (AS/NZS 3000 - Clause 4.3.11).
- Wiring MUST be protected against mechanical failure (AS/NZS 3000 - Clause 3.9).
- The cooker requires a means of all pole disconnection incorporated into the fixed wiring. This MUST have a disconnection gap of 3mm.
- The cooker MUST be properly earthed.

NOTE: When connections are made to a multi-phase 230/240V supply, the bridge piece MUST be removed from between the active connections.

i TIPS & INFORMATION

IMPORTANT: Before you cook in your new oven it is important that the protective oils used in the manufacture of the product be removed.

- Make sure that the room is well ventilated (to allow smoke to escape).
- Run the grill on high for 30 minutes without grill dish.
- Then run the oven on 220°C for 1 hour.

CONNECTING TO SERVICES AND COMMISSIONING

This appliance must be installed by an authorised person, according to all codes and regulations of:

- Electrical supply authorities.
- Building regulations
- Local government and council authorities.
- AS5601/AG601 (particular attention to 5.12.1 and figure 5.1 on page 90, 5.12.1.7).
- AS/NZS 3000 (particular attention to clause 4.3.11 and clause 3.9).

HARD WIRING DETAIL

1. Remove terminal cover plate from rear panel of appliance.
2. Fit wires through hole in cover plate and make connections to terminals.
3. Engage wires into plastic clip. Secure plastic clip with two long silver screws (supplied in separate bag).
4. Replace cover plate onto rear panel.

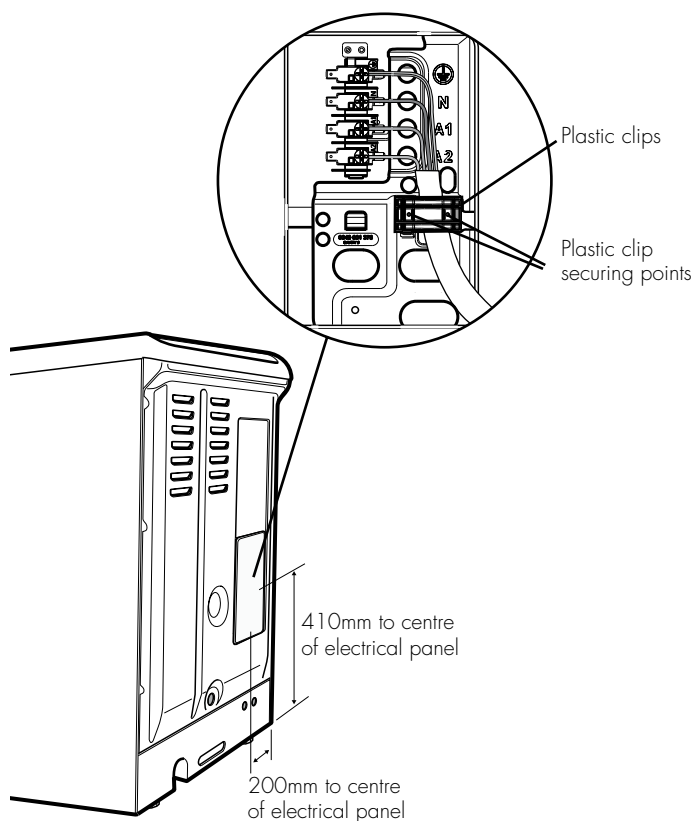

Rear view terminal block position

INSTALLING THE GAS COOKER

Gas connection

Read these points before connecting to the gas supply:

- Slide cooker into final position checking that anti-tilt bracket is engaged and that wiring loops and gas supply are free from jamming and obstacles.
- Fit the supplied pressure regulator for Natural Gas or supplied test point union for LPG appliances using the supplied sealing washer. Ensure the arrow is pointing towards appliance and that the pressure test point is accessible.
- Make the gas connection to the inlet of the regulator or test point adaptor using a fitting to suit 1/2" BSP parallel internal thread found on these fittings. Flexible connections are not permitted with this appliance.

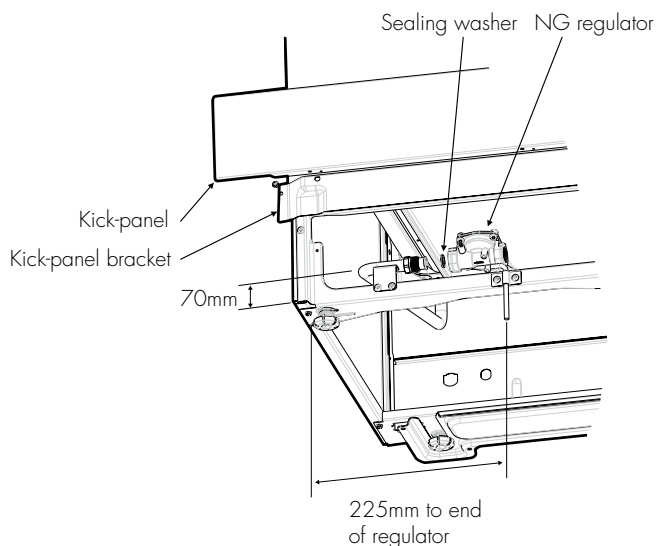

Gas connection front view

CHECKING GAS PRESSURES

The cooker MUST be installed in compliance with:

- the Australian Standard AS5601 (particular reference to clause 5.12.1).
- local gas fitting regulations, municipal building codes and other statutory regulations.

The cookers come in two gas types: Natural gas and Universal LPG. Before installation check that the cooker is suitable for the gas supply. To do this check the gas type on the carton sticker or on the data plate behind the bottom of the oven door.

The following table shows the supply and operating pressures for various gas supplies.

GAS TYPE	NATURAL GAS	UNIVERSAL LPG
SUPPLY PRESSURE at inlet to appliance regulator (if fitted)	1.13 (kPa)	2.75* (kPa)
OPERATING PRESSURE at appliance test point	1.00 (kPa)	2.75 (kPa)

*If the regulator is placed upstream of the cooker inlet, as is normal for cookers operating on LPG, then the supply pressure and operating pressure are the same.

The following table shows the injector sizes for each burner.

INJECTOR ORIFICE	NATURAL GAS	UNIVERSAL LPG
LOW HEAT BURNER	1.00 mm	0.55 mm
MEDIUM HEAT BURNER	1.35 mm	0.70 mm
HIGH HEAT BURNER	1.60 mm	0.90 mm
INTENSE HEAT WOK BURNER	1.75 mm	1.00 mm
OVEN – main injector	1.50 mm	0.82 mm

CHECKING PIPE SIZE

To work out a suitable pipe size for connection use:

- the information in this table.

GAS TYPE	NATURAL GAS	UNIVERSAL LPG
Hourly gas consumption for GSP625/627	51.1MJ/h	44.4MJ/h
Hourly gas consumption for DSP635	40.6MJ/h	35.4MJ/h

- information about the length of the run, number of elbows, tees and bends, the available service pressure and the supply requirements.

NOTE: AS5601 will help you with this matter.

LPG CONVERSION – IMPORTANT (MODEL 635 ONLY)

This appliance is fitted with Natural Gas burner injectors. Please follow the procedure below if a conversion to suit UNIVERSAL LPG is required.

The conversion kit contains 5 injectors and 1 LPG sticker.

1. Remove the hotplate burners to access the hotplate injectors. Replace the factory fitted NG injectors with the appropriate injectors, as supplied (see table on this page).
2. Unscrew the hex nut from the regulator. The hex nut, brass washer and nylon insert will disengage as an assembly.
3. Unclip the nylon insert from the nut assembly by rotating the insert 1/4 turn, and pulling it free.
4. Turn over the insert, and clip back into position.
5. Refit the hex nut assembly to the regulator ensuring that it is fully screwed down. The regulator is now set for connection to LPG.
6. Turn on the gas supply and at each new connection check for leaks using soapy water: each hotplate valve should be turned on, one at a time, and the injector hole blanked off for several seconds.
7. The operation of the regulator can be confirmed by connecting a manometer to the pressure test point located on the side of the regulator body adjacent to the outlet. With the appliance operating check the outlet pressure
 - when all burners of the appliance are operating at maximum,
 - when the smallest burner of the appliance is operating at minimum.Under these conditions the outlet pressure should not vary from the nominal outlet pressure of 2.60kPa by more than $\pm 0.52\text{kPa}$.
8. If the regulator appears to not be performing satisfactorily then check the following points.
 - If the outlet pressure is consistently too low then the inlet pressure may be too low and adjustment of an upstream regulator may be needed, or an upstream regulator or valve with insufficient flow capacity may be present in the gas supply line. If this is suspected then it may be necessary to repeat the checks whilst measuring both the inlet and outlet pressure to determine if the inlet pressure is in the range 2.75 – 7.00kPa.
 - Check that the insert has been fitted correctly.
 - Check that the turret screw is fully screwed down.
 - Check that the regulator has been fitted to the gas supply line in the correct orientation, the arrow on the base of the body indicates the direction of gas flow.Once these checks have been completed, if the regulator still fails to perform in a satisfactory manner it should be replaced.
9. One by one, turn the knobs to minimum and screw in the bypass screw (accessible when the knob is removed) until

a small stable flame results. Turn the knob to maximum and then back to minimum to ensure that the correct minimum flame is maintained.

10. Attach the LPG sticker to the cooker, near the gas supply inlet. Cover the Natural Gas label that is factory fitted.

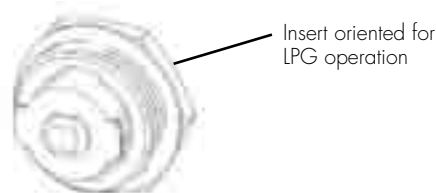
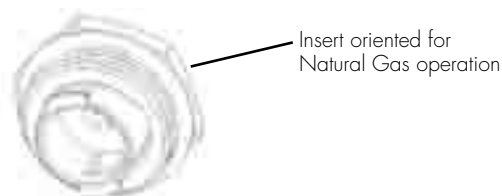
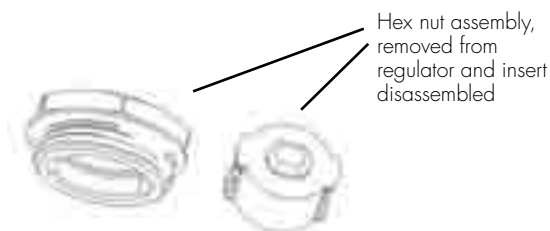
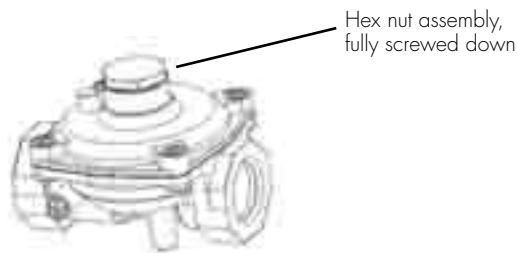

TESTING THE OPERATION

TESTING THE OPERATION OF THE GAS COOKER

NOTE: You **MUST** test the cooker after installation, before you hand it over to the customer.
You **MUST** have a manometer and a connecting tube.

CHECKING GAS SUPPLY

1. Check the manometer zero point is correct.
2. Connect the manometer to the cooker pressure test point. This is located on the regulator or LPG inlet fitting.
3. Turn on the gas supply and the electricity and try to ignite the gas.

NOTE: It will take additional time to light the gas for the first time as air needs to be purged from the pipes.

4. Check the operating pressure for the particular gas type (see table on page 23).

FOR LPG COOKERS: Adjust the regulator if necessary (this may be remote from the cooker).

FOR NATURAL GAS COOKERS

Regulators are supplied pre-adjusted and configured by the component maker for use with Natural Gas. The appliance installer is not required to make an adjustment to obtain the correct outlet pressure setting.

An arrow on the base of the regulator indicates the direction of gas flow when the inlet and outlet of the regulator are orientated correctly. When the regulator has been fitted check for leaks from the connections with soapy water.

CHECKING THE FUNCTION OF THE REGULATOR

With the appliance operating check the outlet pressure:

- when all burners of the appliance are operating at maximum,
- when the smallest burner of the appliance is operating at minimum.

Under these conditions the outlet pressure should not vary from the nominal outlet pressure by more than $\pm 20\%$ of the nominal outlet pressure (ie $\pm 0.20\text{kPa}$ for Natural Gas).

If the regulator appears to not be performing satisfactorily then check the following points.

1. If the outlet pressure is consistently too low then the inlet pressure may be too low and adjustment of an upstream regulator may be needed, or an upstream regulator or valve with insufficient flow capacity may be present in the gas supply line. If this is suspected then it may be necessary to repeat the checks whilst measuring both the inlet and outlet pressure to determine if the inlet pressure is in the range 1.13 – 5kPa.
2. Check that the regulator has been fitted to the gas supply line in the correct orientation, the arrow on the base of the body indicates the direction of gas flow.

Once these checks have been completed, if the regulator still fails to perform in a satisfactory manner it should be replaced.

TESTING THE COOKER FEATURES

- Observe the flame appearance on each burner. If it is much smaller or larger than expected, then the injector size needs checking.

NOTE: When flame is unsatisfactory, then refer to the Electrolux Technical Publications and correct the fault, if possible.

When maximum flame appearance is correct, then check the turn-down setting on each burner. If the settings appear to be incorrect, proceed as follows:

1. Adjust the bypass screw mounted on the body of each hotplate control cock. This is accessible when the control knob and the control panel are removed.
2. Check the ignition on all burners both separately and in combination.
3. Check the operation of the electrical components, if applicable.
4. If you are satisfied that the cooker is operating correctly, then turn it off and show the customer how to use it. Make sure you ask the customer to operate the clock and controls.

NOTE: If the cooker cannot be adjusted to perform correctly, then inform the customer of the problem and put a warning notice on the cooker. If the problem is dangerous, then disconnect the cooker. If there is a fault, then the customer should be advised to contact the manufacturer's local service organisation or the retailer.

Electrolux Warranty

FOR SALES IN AUSTRALIA AND NEW ZEALAND
APPLIANCE: WESTINGHOUSE 600mm SLOT-IN FREESTANDING COOKER

This document sets out the terms and conditions of product warranties. It is an important document. Please keep it with your proof of purchase documents in a safe place for future reference should you require service for your appliance.

General Terms and Conditions

1. In this warranty
 - (a) 'Electrolux' means Electrolux Home Products Pty Ltd ABN 51 004 762 341 in respect of Appliances purchased in Australia and Electrolux (NZ) Limited in respect of Appliances purchased in New Zealand;
 - (b) 'Appliance' means any Electrolux product purchased by you accompanied by this document;
 - (c) 'Warranty Period' means
 - (i) where you use the Appliance for personal, domestic or household purposes in Australia the period of "24" months and in New Zealand the period of "24" months;
 - (ii) where you use the Appliance for commercial purposes, in Australia the period of "3" months and in New Zealand the period of "3" months, (if the period stated is 0 months you are not covered by this product warranty).
2. This warranty only applies to Appliances purchased and used in Australia or New Zealand and is in addition to (and does not exclude, restrict, or modify in any way) any non-excludable statutory warranties in Australia or New Zealand.
3. Electrolux warrants that, when dispatched from an Electrolux warehouse, the Appliance is free from defects in materials and workmanship for the Warranty Period.
4. During the Warranty Period Electrolux or its Authorised Service Centre will, at no extra charge if your appliance is readily accessible without special equipment, and subject to these terms and conditions, repair or replace any parts which it considers to be defective. You agree that any replaced Appliances or parts become the property of Electrolux. This warranty does not apply to light globes, batteries, filters or similar perishable parts.
5. Parts and Appliances not supplied by Electrolux are not covered by this warranty.
6. Where you are within an Electrolux service area, this warranty covers the cost of transport of the Appliance to and from Authorised Service Centres of Electrolux and travelling costs for representatives of the Authorised Service Centre to and from your home or business.
If you are outside an Electrolux service area, you will bear these costs. For information about whether you are within an Electrolux service area, please phone 13 13 49 in Australia, or 0800 10 66 10 in New Zealand.
7. Proof of purchase is required before you can make a claim under this warranty.
8. You may not make a claim under this warranty unless the defect claimed is due to faulty or defective parts or workmanship. Electrolux is not liable in the following situations (which are not exhaustive):
 - (a) The Appliance is damaged by:
 - (i) accident
 - (ii) misuse or abuse, including failure to properly maintain or service

- (iii) normal wear and tear
 - (iv) power surges, electrical storm damage or incorrect power supply
 - (v) incomplete or improper installation
 - (vi) incorrect, improper or inappropriate operation
 - (vii) insect or vermin infestation.
 - (b) The Appliance is modified without authority from Electrolux in writing.
 - (c) The Appliance's serial number or warranty seal has been removed or defaced.
 - (d) The Appliance was serviced or repaired by anyone other than Electrolux or its Authorised Service Centres.
9. This warranty, the contract to which it relates and the relationship between you and Electrolux are governed by the law applicable in the Australian State where the Appliance was purchased or the law applicable in New Zealand if the Appliance was purchased in New Zealand. Where the Appliance was purchased in New Zealand for business purposes the Consumer Guarantee Act does not apply.

Limitation of Liability

10. To the extent permitted by law:
 - (a) Electrolux excludes all warranties other than as contained in this document;
 - (b) Electrolux shall not be liable for any loss or damage whether direct or indirect or consequential arising from your purchase, use or non-use of the Appliance.
11. Provisions of the Trade Practices Act and State consumer legislation in Australia, and the Consumer Guarantees Act, the Sale of Goods Act and the Fair Trading Act in New Zealand, imply warranties or conditions, or impose obligations, upon Electrolux which cannot be excluded, restricted or modified. To the extent permitted by law, the liability of Electrolux (if any) arising out of or in relation to the Appliance or any services supplied by Electrolux shall be limited (where it is fair and reasonable to do so):
 - (a) in the case of Appliances, at its option, to the replacement or repair of the Appliances or the supply of equivalent products or the payment of the cost of replacing the Appliances or having the Appliances repaired or of acquiring equivalent Appliances. Upon being replaced, parts and Appliances become the property of Electrolux; or
 - (b) in the case of services, at its option, to the supply of the services again or the payment of the cost of having the services re-supplied; and in the case of Appliances or services supplied in New Zealand, loss or damage whether direct or indirect or consequential that is reasonably foreseeable.

Privacy

You acknowledge that in the event that you make a warranty claim it will be necessary for Electrolux and its Authorised Service Centres to exchange information in relation to you to enable Electrolux to meet its obligations under this warranty.

Important Notice

Before Calling a Service Technician please check carefully the operating instructions, service booklet and the warranty terms and conditions.

<p>FOR SERVICE or to find the address of your nearest state service centre in Australia PLEASE CALL 13 13 49 For the cost of a local call (Australia only)</p>	<p>SERVICE AUSTRALIA  ELECTROLUX HOME PRODUCTS www.electrolux.com.au</p>	<p>FOR SPARE PARTS or to find the address of your nearest state spare parts centre in Australia PLEASE CALL 13 13 50 For the cost of a local call (Australia only)</p>
<p>FOR SERVICE or to find the address of your nearest authorised service centre in New Zealand FREE CALL 0800 10 66 10 (New Zealand only)</p>	<p>SERVICE NEW ZEALAND  ELECTROLUX HOME PRODUCTS www.electrolux.co.nz</p>	<p>FOR SPARE PARTS or to find the address of your nearest state spare parts centre in New Zealand FREE CALL 0800 10 66 20 (New Zealand only)</p>



**For more information on all Westinghouse appliances,
or for dimension and installation information, call into your retailer,
phone or email our customer care team or visit our website:**

AUSTRALIA

phone: 1 300 363 640
fax: 1 800 350 067
email: customercare@electrolux.com.au
web: www.westinghouse.com.au

NEW ZEALAND

phone: 09 573 2384
fax: 0800 363 600
email: customercare@electrolux.co.nz
web: www.westinghouse.co.nz



TOP SERVICE

Top Service encompasses the after sales service provided by The Electrolux Group to consumers including delivery, home service and spare parts.

**Westinghouse. We are part of the Electrolux family.
Share more of our thinking at www.electrolux.com**

© 2009 Electrolux Home Products Pty Ltd ABN 51 004 762 341
Print code: W600FSUM_Jul09

Part number: 0342-001-542 09A065A Rev C July 09



Westinghouse