

# VOLTA

U2950 Series

## OWNER'S GUIDE



*Thank you for purchasing your new Volta Vacuum!*

In the unlikely event you experience any problems with this product, rather than taking it back to the shop, please telephone the  
**VOLTA CUSTOMER HELPLINE**

**AUS: 1300 365 305**

during AEST

**NZ: 0508 730 730**

Upright Vacuum Cleaner  
Household Type

# Where to Find Important Vacuum Information

## Please Retain

Record the model, type and serial number below.

Date of Purchase \_\_\_\_\_ (keep your receipt)

Model & Type \_\_\_\_\_

Serial Number \_\_\_\_\_

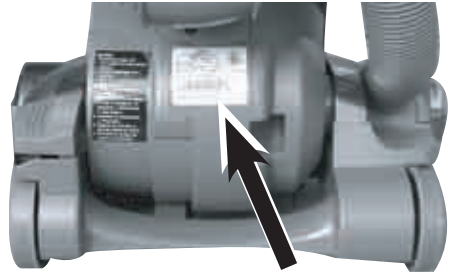

This information is located on the rating plate on the lower back side of the vacuum.

## Before You Start Your Vacuum Cleaner

**Refer to Quick Start Guide for assembly and use. This Owner's Guide provides important instructions to prolong the life of your Volta vacuum cleaner.**

### Inspection

Carefully unpack and inspect your new Volta vacuum cleaner for shipping damage. Each unit is tested and thoroughly inspected before shipping. For instructions regarding any shipping damage, call Volta Customer **HELPLINE**.

### Table of Contents

<b>Important Safeguards</b> .....	<b>1</b>
<b>How to Identify Parts of Vacuum Cleaner</b> .....	<b>2</b>
<b>Filter Maintenance Schedule</b> .....	<b>2</b>
Filter screen, foam filter, filter frame and HEPA filter.	
<b>How to Use Accessories</b> .....	<b>3</b>
Telescopic self-cleaning duster, crevice tool, extension wand, dusting brush, Turbo Brush and stair hose.	
<b>How to Maintain Your Vacuum Cleaner</b> .....	<b>4</b>
Maintain brush roll, and replace ZE090 brush roll belt.	
<b>How to Clear a Blockage</b> .....	<b>5</b>
Hose blockages.	
<b>Thermal Cut-Off</b> .....	<b>5</b>
<b>Warranty</b> .....	<b>6</b>
<b>Problem Solving</b> .....	<b>7</b>



Follow caution information wherever you see this symbol.



**applian**

Australia's la

# IMPORTANT SAFEGUARDS

When using an electrical appliance, basic precautions should always be followed, including the following:

## READ ALL INSTRUCTIONS BEFORE USING THIS VACUUM CLEANER WARNING



**To reduce the risk of fire, electric shock, or injury:**

- Do not use outdoors or on wet surfaces.
- **Do not leave vacuum when plugged in.** Turn off the switch and unplug the electrical cord when not in use and before servicing.
- This appliance is not intended for use by any persons (including children) with reduced physical, sensory or mental capabilities, or lack of experience and knowledge, unless they have been given supervision or instruction concerning use of the appliance by a person responsible for their safety.
- Children should be supervised to ensure that they do not play with the appliance.
- Use only as described in this manual. Use only manufacturer's recommended attachments.
- Do not use with damaged cord or plug. If vacuum is not working as it should, has been dropped, damaged, left outdoors, or dropped into water, return it to a service centre before using.
- Do not pull or carry by cord, use cord as a handle, close a door on cord, or pull cord around sharp edges or corners.
- Do not run vacuum over cord. Keep cord away from heated surfaces.
- Do not use extension cords or outlets with inadequate current carrying capacity.
- Turn off all controls before unplugging.
- Do not unplug by pulling on cord. To unplug, grasp the plug, not the cord.
- Do not handle plug or vacuum with wet hands.
- Do not put any object into openings. Do not use with any opening blocked; keep free of dust, lint, hair, and anything that may reduce air flow.
- This vacuum creates suction and contains a revolving brushroll. Keep hair, loose clothing, fingers, and all parts of body away from openings and moving parts.
- Do not place vacuum on furniture or stairs as the brushroll may cause damage. Place vacuum on floor with the handle in storage position while using attachments.
- Do not pick up anything that is burning or smoking, such as cigarettes, matches, or hot ashes.
- Do not use without the dust cup or filter(s) in place.
- Belt pulleys can become hot during normal use. To prevent burns, avoid touching the belt pulley when servicing the drive belt.
- Use extra care when cleaning on stairs.
- Do not use to pick up flammable or combustible liquids such as gasoline, or use in areas where they may be present.
- Store your vacuum indoors in a cool, dry area.
- Keep your work area well lighted.
- Unplug electrical appliances before vacuuming them.
- Unplug before connecting Turbo Brush. Not for use on animals.

## PLEASE SAVE THESE INSTRUCTIONS

### WARNING

**The brush in the cleaning head rotates at high speed and can cause damage to the mains supply cable if the vacuum passes over it during cleaning operations.**

Care should be taken to ensure that this does not happen. If the cleaning head has accidentally passed over the mains supply cable the following action should be taken:

1. Switch off and remove the plug from the socket outlet.
2. Examine the mains supply cable for damage (only after removing the plug from the socket outlet).
3. If there is any sign of damage to the supply cable it **MUST** be renewed. The repair **MUST** be carried out by a Volta Service Agent or a similar qualified person.
4. **NEVER** use the machine with a damaged mains supply cable.



# How to Identify Parts of Vacuum Cleaner

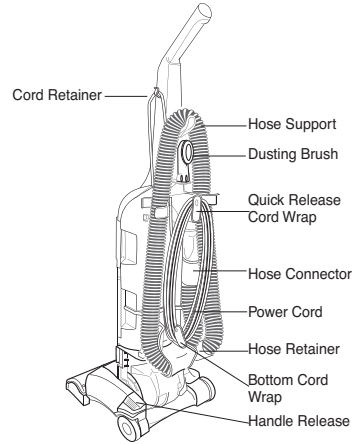
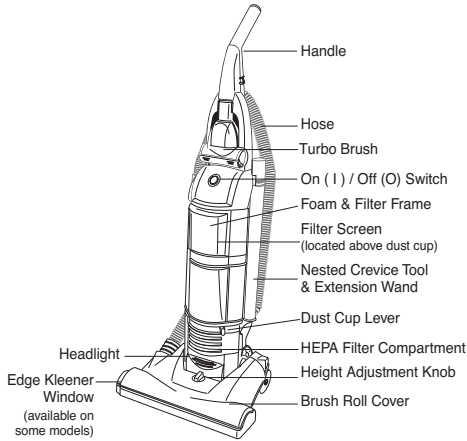

## Filter Maintenance Schedule

**Maintenance Schedule is also located on back side of dust cup.**



Assemble the vacuum cleaner before using. Moving parts. Make sure ON/OFF switch is in OFF (O) position before plugging in power cord.

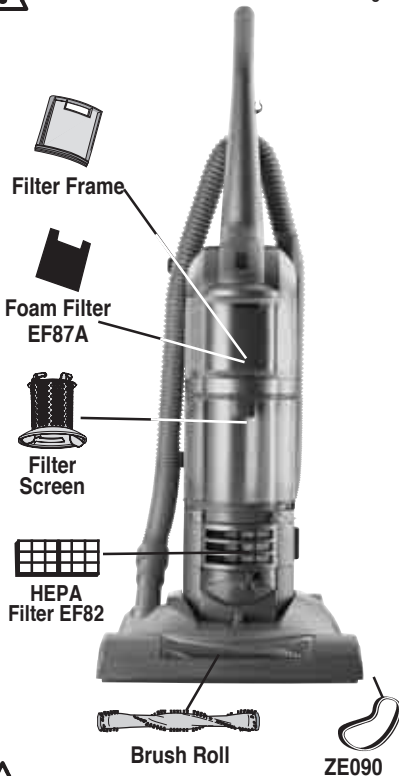

### FREQUENCY

#### EACH USE

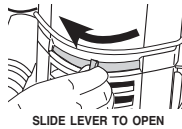

#### DUST CUP – Empty

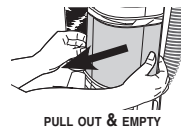

#### WEEKLY

#### FILTER SCREEN – Wash & Clean



#### WEEKLY

#### FOAM & CLOTH FILTER – Wash & Dry

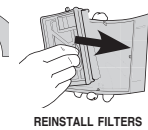
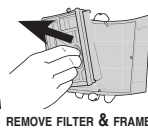

#### 6 MONTHS

#### HEPA FILTER – Replace

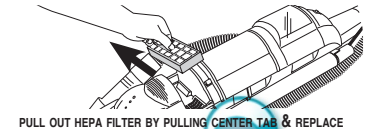

#### MONTHLY

#### BRUSH ROLL – Clean



#### BELT – Replace a worn, cut or out-of-shape belt



Due to the powerful motor fitted to this vacuum, you may notice a higher level of noise than that of your previous model, and that it will pick up considerably more than your old model. You may need to empty the dust cup more frequently as a result of this better pickup.

# How to Use Accessories



**Vacuum Cleaner handle must be in upright position.**

**Be sure to raise height adjustment setting before using attachments.**

**Replace hose into hose retainer after using accessories.**



**Do not allow cleaner to tilt forward when using accessories. Do not place cleaner on furniture or stairs for any period of time as the brush roll may cause damage.**

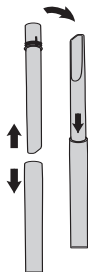

## Combination Crevice Tool and Extension Wand

Baseboards, corners & between cushions

- 1) Grasp crevice tool near ridges and pull apart.
- 2) Turn ridge end to center.
- 3) Push crevice tool into wand and place on end of hose.

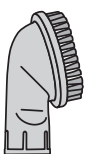
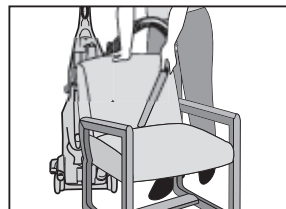
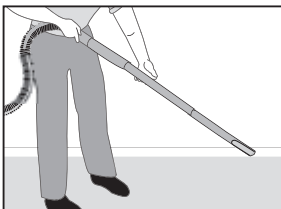

## Dusting Brush

Furniture, drapes, blinds, bookshelves, lampshades and vents.

- 1) Remove hose from hose retainer from back of vacuum.
- 2) Place dusting brush on end of hose, wand or crevice tool.

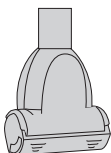
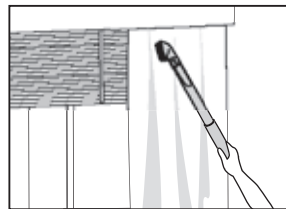
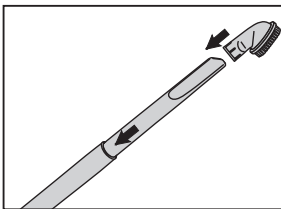

## Turbo Brush and Stair Hose

Furniture and stairs. Some vacuum models have an additional stair hose – Part number 70947-5.

**Make sure vacuum is below you, pushed against the bottom step.**

- 1) If model has additional stair hose, attach to end of hose.
- 2) Attach Turbo Brush to the end of wand and hose.

**Vacuum must be turned off before removing debris from Turbo Brush.**

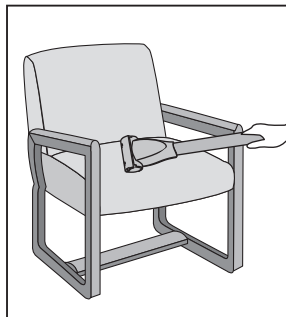

## Stair Hose, Hard Floor Nozzle, and additional wands (On Some Models - Contact Customer Service to order)

An additional Stair Hose, Hard Floor Nozzle and additional tubes can be purchased. When attached to the hose on the cleaner you can clean a full flight of stairs without moving the cleaner. An additional set of tubes and hard floor nozzle can be purchased. When attached to the hose on the cleaner you can clean hard floors. Contact our Customer Care representatives.



**When cleaning stairs, do not place the cleaner on the stairs or on a stair above you. This unit is fitted with a constantly rotating brush roll. Care should be taken when using the hose to clean stairs that the back - not the front of the unit is placed against the base of the stairs. This will prevent the unit leaning forward and causing possible damage to carpets or floors.**



# How to Maintain Your Vacuum Cleaner

Make sure vacuum cleaner is turned off and power cord is unplugged

## Maintain Brush Roll

Motor can become hot with normal use.

Do not remove end caps. Remove hair and threads from brush roll periodically.



Care should be taken when vacuuming rugs to ensure that edges and fringes do not snap the drive belt and stop the rotation of the brush roll.



## Check ZE090 Belt if Worn, Cut or Out of Shape

Avoid touching the motor shaft when checking brush roll belt.

- 1) Use handle release to lower handle flat onto floor (Fig. 1).
- 2) Remove 2 screws from the front side of brush roll cover (Fig. 2).
- 3) Lift and remove brush roll cover (Fig. 3).
- 4) Remove brush roll and belt. Thread new belt around motor shaft and brush roll (Fig. 4).
- 5) Insert left end of brush roll first. Make sure square on brush roll cap is in place. Pull right side of brush roll to stretch belt. Secure right end cap into base (Fig. 5).
- 6) Rotate brush roll 2 turns to center belt.
- 7) Replace brush roll cover (Fig. 2).
- 8) Replace 2 screws (Fig 6).

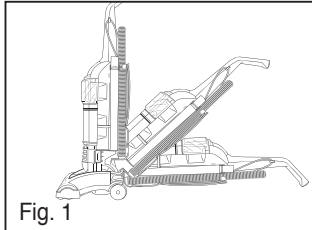

Fig. 1

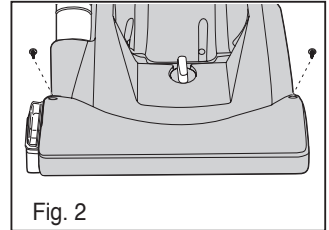

Fig. 2

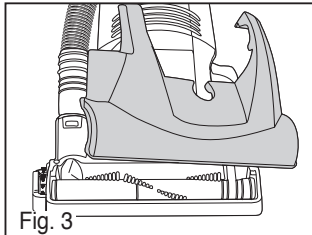

Fig. 3

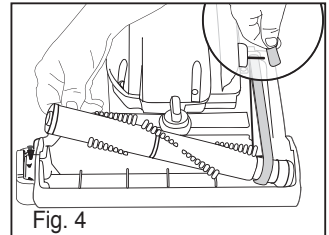

Fig. 4

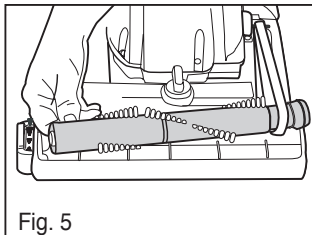

Fig. 5

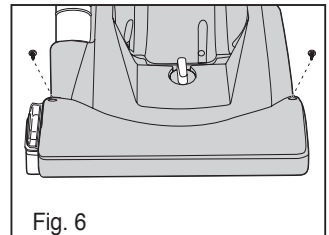

Fig. 6



## How to Clear a Blockage

Make sure vacuum is turned off and power cord is unplugged.

### Hose Blockage

- 1) Remove hose from hose retainer. Flexing the hose will loosen any blockage (Fig 1).
- 2) Base hose – remove 2 screws and brush roll cover. Clear blockage from base hose. Check for debris in brush roll and replace screws and cover (Fig 2).
- 3) Hose connector – twist hose from connector. Remove blockage and replace hose. For better access, unclip sides and clear blockage. Clip back into place and reconnect hose at both ends (Fig 3).

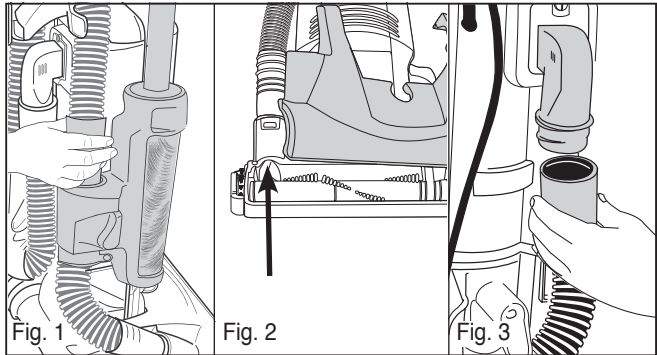

### Thermal Cut-Off

This vacuum has a special thermostat that protects the vacuum in case of motor overheating. If the vacuum switches off, push the switch pedal once and unplug the vacuum. Check the vacuum for a possible source of overheating such as a full dust cup, a blocked hose or clogged filter. If these conditions are found, fix them and wait at least 30 minutes before attempting to use the vacuum. After the 30 minute period, plug the vacuum back in and push the on/off switch On ( I ). If the vacuum still does not run, please call Volta Customer Care.

### Service

Should you require service on your Volta vacuum, please telephone Volta Customer HELPLINE AUS: 1300 365 305 during AEST. NZ: 0508 730 730. Before requesting service, please check whether your problem is covered under Service Checklist (see below).

New filter pads, brush rolls and drive belts can be obtained from Volta Retailers. If difficulty is experienced in obtaining spares, please contact Volta Customer HELPLINE AUS: 1300 365 305 during AEST. NZ: 0508 730 730.

### Service Checklist

- If your vacuum will not operate, check the plug connection and mains fuse.
- Never allow the dust cup to become so full that it impedes the air flow, thus reducing the cleaning efficiency of the machine. The character of household dust and its effect on the air flow through the machine may vary considerably. Fluffy dust allows air to pass through readily whereas fine powdery dust or proprietary cleaning powders pack tightly in the dust cup, offering greater resistance to air flow and will reduce cleaning efficiency if the cup becomes overloaded.
- Always store your vacuum and spare dust filters in a dry place.
- Renew the filter pads three or four times a year. This is essential to ensure continued high filtration of dust particles.

- Sucking up such items as stockings, clippings of cloth, sizeable pieces of paper, wrappings from cigarette packets or sweets etc., may block the hose. Volta regrets that the clearing of blocked hoses cannot be regarded as service that can be given free of charge, under the guarantee. Should a blockage occur, first disconnect the vacuum from the electricity supply, refer to section headed "How to Clear a Blockage." If these operations are not successful, contact Volta AUS: 1300 365 305 during AEST. NZ: 0508 730 730.

- Never pick up hot cinders or lighted cigarette ends.

- **Make certain that your vacuum does not come into contact with water or any other liquid. It is not designed as a wet pick up vacuum, and must never be used on damp carpets or wet floors.**

Important – in the event of the mains supply cable of this vacuum requiring replacement, we recommend that this be carried out by Volta Service Staff.

### Spares

New filters, brush rolls and drive belts can be obtained from Authorised Volta Dealers and electrical retailers. If difficulty is experienced in obtaining spares please call Volta AUS: 1300 365 305 during AEST. NZ: 0508 730 730.



Australia's la

## WARRANTY

This page sets out the terms and conditions of product warranties for Volta branded vacuums from the Electrolux Group. Please keep with your proof of purchase documents in a safe place for future reference should you require service for your Volta appliance.

### General Terms and Conditions

In this warranty Electrolux means Electrolux Pty Ltd ABN 21 000 015 136 in respect of Appliances purchased in Australia and Electrolux (NZ) Limited in respect of Appliances purchased in New Zealand;

'Appliance' means any Volta branded product purchased by you accompanied by this document;

'Warranty Period' means where you use the Appliance for personal, domestic or household purposes in Australia and in New Zealand, the period of 24 months; where you use the Appliance for commercial purposes, the period of 3 months following the date of original purchase of the Appliance; 'you' means the purchaser of the Appliance not having purchased the appliance for re-sale, and 'your' has a corresponding meaning.

- 1) This warranty only applies to Volta branded appliances purchased and used in Australia or New Zealand and is in addition to (and does not exclude, restrict, or modify in any way) any non-excludable statutory warranties in Australia or New Zealand.
- 2) Electrolux warrants that, when dispatched from an Electrolux warehouse, the Volta branded appliance is free from defects in materials and workmanship for the Warranty Period.
- 3) During the warranty period Electrolux or its Authorised Service Centre will, at no extra charge and subject to these terms and conditions, repair or replace any parts which it considers to be defective. You agree that any replaced Appliances or parts become the property of Electrolux. This warranty does not apply to bonus giveaways or batteries, drive belts, filters, accessories or similar consumable parts.
- 4) You are responsible for paying all service call fees and/or transport charges and/on damages and loss incurred in connection with transportation of this appliance to and from Electrolux or its duly appointed service provider's premises.
- 5) Parts and appliances not supplied by Electrolux are not covered by this warranty.
- 6) Proof of purchase is required before you can make a claim under this warranty. You may not make a claim under this warranty unless the defect claimed is due to faulty or defective parts or workmanship. Electrolux is not liable in the following situations (which are not exhaustive):

A) The Appliance is damaged by:

- (i) use with anything other than Volta genuine spare parts
- (ii) accident
- (iii) vacuuming up wet materials or construction/building materials that is not normal day to day domestic dry use
- (iv) misuse, neglect or abuse, including failure to properly maintain or service
- (v) normal wear and tear
- (vi) power surges, electrical storm damage or incorrect power supply.
- (vii) incomplete or improper installation
- (viii) incorrect, improper or inappropriate operation
- (ix) insect or vermin infestation.

B) The Appliance is modified without authority from Electrolux in writing.

C) The Appliance's serial number or warranty seal has been removed or defaced.

D) The Appliance was serviced or repaired by anyone other than Electrolux or its Authorised Service Centres.

This warranty, the contract to which it relates and the relationship between you and Electrolux are governed by the law applicable in the State where the Appliance is purchased if the Appliance is purchased in Australia or the law applicable in New Zealand if the Appliance is purchased there. Where the Appliance is purchased in New Zealand for business purposes the Consumer Guarantee Act does not apply.

### Limitation of Liability

To the extent permitted by law:

A) Electrolux excludes all warranties other than as contained in this document;

B) Electrolux shall not be liable for any loss or damage whether direct or indirect or consequential arising from your purchase, use or non-use of the Appliance.

Provisions of the Trade Practices Act and State consumer legislation in Australia, and the Consumer Guarantees Act, the Sale of Goods Act and the Fair Trading Act in New Zealand, imply warranties or conditions, or impose obligations, upon Electrolux which cannot be excluded, restricted or modified. To the extent permitted by law, the liability of Electrolux (if any) arising out of or in relation to the Appliance or any services supplied by Electrolux shall be limited (where it is fair and reasonable to do so), in the case of Appliances, at its option, to the replacement or repair of the Appliances or the supply of equivalent products or the payment of the cost of replacing the Appliances or having the Appliances repaired or of acquiring equivalent Appliances. Upon being replaced, parts and Appliances become the property of Electrolux; or in the case of services, at its option, to the supply of the services again or the payment of the cost of having the services re-supplied; and in the case of Appliances or services supplied in New Zealand, loss or damage whether direct or indirect or consequential that is reasonably foreseeable.

### Privacy

You acknowledge that in the event that you make a warranty claim it will be necessary for Electrolux and its Authorised Service Centres to exchange information in relation to you to enable Electrolux to meet its obligations under this warranty.



# Problem Solving

 **Make sure vacuum is turned off and power cord is unplugged.**

Problem	Cause	Solution
<b>Motor will not start.</b>	Power plug	<ul style="list-style-type: none"> <li>• Push plug securely into outlet.</li> <li>• Try another outlet.</li> <li>• Check circuit breaker.</li> <li>• Turn On / Off switch to on ( I )</li> </ul>
	On / Off switch	<ul style="list-style-type: none"> <li>• Turn On / Off switch to on ( I )</li> </ul>
<b>Vacuum does not clean carpet or hard floor.</b>	Dust cup and filters	<ul style="list-style-type: none"> <li>• Empty dust cup and/or change filters.</li> <li>• If picking up fine dust, the dust cup may not look full, but a fine substance tends to reduce suction when it blocks air flow through the foam filter and filter screen. Refer to page 2 for filter maintenance. Make sure foam filter, filter screen and dust cup are installed properly.</li> </ul>
	Belt	<ul style="list-style-type: none"> <li>• Replace a worn, cut or out-of-shape belt. Page 4</li> </ul>
	Hose	<ul style="list-style-type: none"> <li>• Remove clogs from the hose that restrict the airflow. Make sure hose is replaced into hose retainer. Page 5</li> </ul>
	Hard floor setting	<ul style="list-style-type: none"> <li>• For hard floor cleaning, turn height adjustment knob to hard floor position. Refer to Quick Start Guide.</li> </ul>
	Carpet height setting	<ul style="list-style-type: none"> <li>• For carpet cleaning, turn height adjustment knob to another position. Refer to Quick Start Guide.</li> </ul>
<b>No suction at the end of hose.</b>	Dust cup and filters	<ul style="list-style-type: none"> <li>• Empty the dust cup and/or change the filters</li> <li>• If picking up fine dust, the dust cup may not look full, but a fine substance tends to reduce suction when it blocks air flow through the foam filter and filter screen. Refer to page 2 for filter maintenance. Make sure foam filter, filter screen and dust cup are installed properly.</li> </ul>
	Filter screen	<ul style="list-style-type: none"> <li>• (Located above the dust cup). Check &amp; clean debris to maintain full air flow. Page 2</li> </ul>
	Hose	<ul style="list-style-type: none"> <li>• Remove clogs from the hose that restrict the airflow. Make sure hose is replaced into hose retainer. Page 5</li> </ul>
<b>Vacuum is hard to push.</b>	Vacuum height setting	<ul style="list-style-type: none"> <li>• Adjust knob to a higher position. Refer to Quick Start Guide.</li> </ul>
	Belt	<ul style="list-style-type: none"> <li>• Replace a worn, cut or out-of-shape belt. Page 4</li> </ul>
<b>Brush roll will not turn.</b>	Belt	<ul style="list-style-type: none"> <li>• Check brush roll for debris. Page 4</li> </ul>
		<ul style="list-style-type: none"> <li>• Replace broken or out-of-shape belt. Page 4</li> </ul>





**Thank you for purchasing a Volta Vacuum Cleaner!**

**If you experience any problems  
with your vacuum, don't struggle  
taking it back to the shop.**

**Call Volta Customer**

**HELPLINE**

**AUS: 1300 365 305**

during AEST

**NZ: 0508 730 730**

**Don't Forget to Use  
Genuine Volta Belts and Filters**

Caution: Damages caused by the use of non-genuine  
parts are not covered by the Volta Guarantee.



Australia's la

**VOLTA**