



COMMERCIAL DESIGN GUARANTEED PERFORMANCE

VARIABLE TEMPERATURE KETTLE

Instruction Booklet

Please read these instructions carefully and retain for future reference



KE9600

Contents

Sunbeam's Safety Precautions	1
Congratulations	2
Features of your Café Series®	
Variable Temperature Kettle	3
Using your Café Series®	
Variable Temperature Kettle	5
Tea Brewing Styles and Tips	7
Sunbeam's 3-Way Safety System	8
Care and Cleaning	9

Important instructions – retain for future use.

تأكد من تفهم احتياطات السلامة المذكورة اعلاه

請務必理解上述的安全預防措施。

Assurez-vous que les précautions ci-dessus relatives à la sécurité sont bien comprises

Versichern Sie sich, dass die obenstehenden Sicherheitsmaßnahmen verstanden werden

Βεβαιώνετε πως οι παραπάνω προφυλάξεις ασφαλείας γίνονται κατανοητές

Pastikan bahwa tindakan-tindakan keselamatan seperti di atas dimengerti anda

Accertatevi che le suddette norme di sicurezza siano comprese a dovere

上記の注意事項をよくお読みになり、安全を御確認ください

Уверете се дека погоре споменатите мерки на претпазливост се добро разбрани

Asegúrese de que las precauciones de seguridad precedentes sean bien comprendidas

کاری یکنید که احتیاطهای بالا حتماً درک بشوند

ต้องแน่ใจว่า ข้อควรระวังเรื่องความปลอดภัยข้างต้น เป็นที่เข้าใจกันดี

Yukarda belirtilen güvenlik önlemlerinin anlaşılığundan emin olunuz

Xin kiểm chắc rằng những biện pháp làm an toàn kể trên được hiểu rõ

Sunbeam's Safety Precautions

SAFETY PRECAUTIONS FOR YOUR SUNBEAM KETTLE.

- Boiling water will scald. Do not leave a boiling or hot kettle near or where children may touch it.
- Boiling water may be ejected, if overfilled.
- Do not leave the power cord near the edge of a bench top where children may touch or pull it.

Sunbeam is very safety conscious when designing and manufacturing consumer products, but it is essential that the product user also exercise care when using an electrical appliance. Listed below are precautions which are essential for the safe use of an electrical appliance:

- Read carefully and save all the instructions provided with an appliance.
- Always turn the power off at the power outlet before you insert or remove a plug. Remove by grasping the plug - do not pull on the cord.
- Turn the power off and remove the plug when the appliance is not in use and before cleaning.
- Do not use your appliance with an extension cord unless this cord has been checked and tested by a qualified technician or service person.
- Always use your appliance from a power outlet of the voltage (A.C. only) marked on the appliance.
- This appliance is not intended for use by persons (including children) with reduced physical, sensory or mental capabilities, or lack of experience and knowledge, unless they have been given supervision or instruction concerning use of the appliance by a person responsible for their safety.
- Children should be supervised to ensure that they do not play with the appliance.
- The temperature of accessible surfaces may be high when the appliance is operating or when the heating cycle has finished
- Never leave an appliance unattended while in use.

- Do not move kettle while switched on.
- Always turn the power off and unplug the cord while the kettle is NOT in use.
- Do not operate the kettle without water.
- Your Café Series® Variable Temperature Kettle must only be used with the power base supplied.
- Always operate the kettle on a flat, level surface.

-
- Do not use an appliance for any purpose other than its intended use.
 - Do not place an appliance on or near a hot gas flame, electric element or on a heated oven.
 - Do not place on top of any other appliance.
 - Do not let the power cord of an appliance hang over the edge of a table or bench top or touch any hot surface.
 - Do not operate any electrical appliance with a damaged cord or after the appliance has been damaged in any manner. If damage is suspected, return the appliance to the nearest Sunbeam Appointed Service Centre for examination, repair or adjustment.
 - For additional protection, Sunbeam recommend the use of a residual current device (RCD) with a tripping current not exceeding 30mA in the electrical circuit supplying power to your appliances.
 - Do not immerse the appliance in water or any other liquid unless recommended.
 - Appliances are not intended to be operated by means of an external timer or separate remote control system.
 - This appliance is intended to be used in household and similar applications such as: staff kitchen areas in shops, offices and other working environments; farm houses; by clients in hotels, motels and other residential type environments; bed and breakfast type environments.

If you have any concerns regarding the performance and use of your appliance, please visit www.sunbeam.com.au or contact the Sunbeam Consumer Service Line. Ensure the above safety precautions are understood.

Congratulations

Congratulations on the purchase of your Sunbeam Café Series® Variable Temperature Kettle

The Sunbeam Café Series® delivers quality, style and superior performance capturing the essence of the commercial kitchen.

Inspired by heavy-duty equipment found in restaurants, cafes and bars, the Sunbeam Café Series® is built to last. It brings together a range of appliances designed to expertly create authentic café food and beverages at home.

Uncompromising blends of stainless steel, brass and die-cast alloy characterise the range. This combined with advanced technology and functional design, guarantee the performance, that each product will surpass expectations.

The Sunbeam Café Series® Variable Temperature Kettle is designed with quality stainless steel components and includes many features that will help you brew the perfect cup of tea.

Features of your Cafe Series® Variable Temperature Kettle

Stylish stainless steel design

Long life stainless steel with a premium brushed and polished finish delivers quality and style to suit any kitchen décor.

2400 watt concealed element

The fast boil 2400 watt element is concealed in the base of the kettle for longer element life. The smooth stainless floor reduces scale build up and allows for easy cleaning.

Twin water level gauges

Full length water gauge indicates the volume of water in the kettle up to 1.8L. The two gauges make the kettle convenient to use for both left and right handed users.

360 degree cordless power base

Designed to allow you to place the kettle on the base in any direction. Convenient for both left and right handed users.

Cord storage facility

Excess cord can be wound around the cord storage facility underneath the power base.

Removable mesh filter

Keeps the water clean of any foreign matter and is removable for easy cleaning.

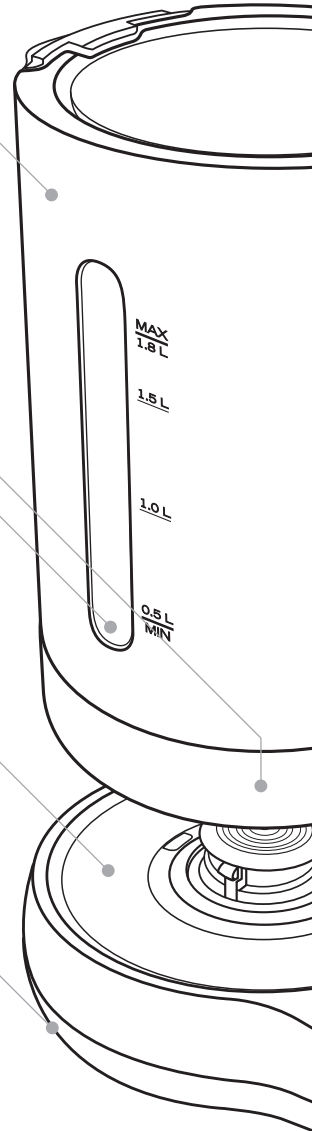
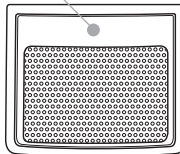

3-Way Safety System

- 1 – Automatically switches the kettle off after boiling.
- 2 – Cuts out for boil-dry protection.
- 3 – Shuts down in case of an electrical fault.

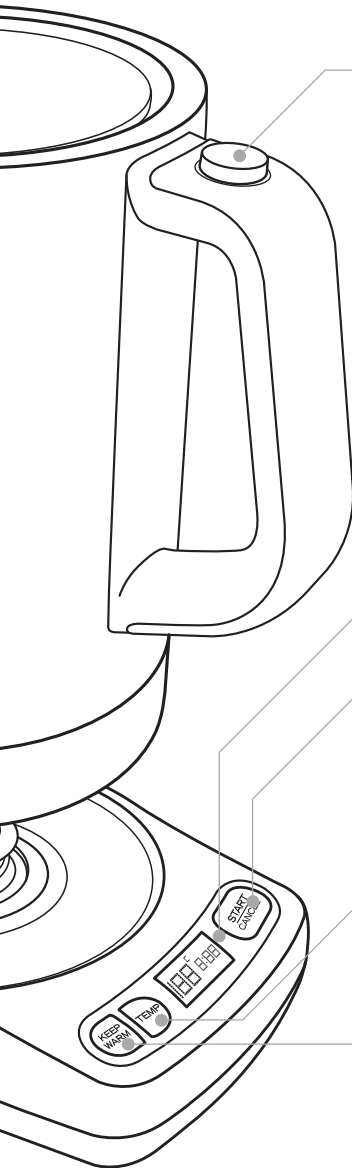

Hinged locking lid

For ease of use the lid is activated by a single press of a button. The design is ideal for one-handed filling and also locks shut to prevent accidental scalding.

Power base with LCD display panel

The LCD screen displays the current temperature and the selected temperature. When the heating cycle is in progress it also displays the amount of time remaining (in minutes and seconds) before the selected temperature is reached.

START / CANCEL

Once the desired temperature has been selected the START/CANCEL button initiates the heating cycle.

It is also a quick start function. If the START/CANCEL button is pressed before a temperature is selected, the previous settings are initiated.

Temp

Enables the user to select from 5 different temperatures; 80°C, 85°C, 90°C, 95°C and 100°C (boil).

Keep warm feature

Convenient Keep Warm feature allows you to maintain the selected water temperature for up to 20 minutes.

Using your Cafe Series® Variable Temperature Kettle

Before using your kettle.

It is recommended that you clean your kettle before using it by filling the kettle with water to the maximum level indicator, boiling the water and discarding.

Important: Do not fill the kettle over the maximum level, as water may spill out of the spout when boiling.

1. To fill the kettle, remove it from the power base and lift the lid, by pressing the button at the top of the handle. Do not fill the kettle below the 'min' indication.
2. Fill the kettle with the desired amount of water. Always fill the kettle between the minimum and maximum marks. Too little water will result in the kettle switching off before the water has boiled.
3. Push the lid closed firmly until it locks into position.
4. Place the kettle onto the power base. Plug the power cord into a 230-240 Volt AC power outlet and switch the power on.

Note: If the kettle is not positioned on top of the power base correctly the LCD panel will show “---:---”.

Using your Cafe Series® Variable Temperature Kettle

Tip: The Variable Temperature Kettle has five optimum tea temperatures you can select from: 80°C, 85°C, 90°C, 95°C and 100°C (boil). Refer to the 'Tea Brewing Styles and Tips' table on page 8 for the ideal water temperature for your tea.

Note: The temperature settings are a guide only and may vary depending on personal preference.

1. Press the 'TEMP' button to select from five pre-set temperatures: 80°C, 85°C, 90°C, 95°C and 100°C (boil). Your selected water temperature will be displayed on the LCD display for 3 seconds. Press 'START/CANCEL' to initiate the heating cycle.

Note: If after 3 seconds nothing is pressed, the LCD display will revert back to showing the current water temperature.

Note: If the START/CANCEL button is pressed without any temperatures being selected beforehand, it will automatically default to the last used setting. The START/CANCEL button is originally preset to 100°C (boil).

2. When the heating cycle is initiated, the LCD display will show the maximum amount of time required to reach the selected water temperature. The Time to Boil feature shown on the LCD display will count down and flash until the correct time is calculated. Once the correct time is calculated the Time to Boil recalibrates to the correct time remaining and will no longer flash.

Note: The maximum amount of time is dependent on the ambient temperature of the water. The colder the initial water temperature the longer the heating cycle. For example, if the initial temperature is 20°C the time to boil feature will show a maximum time of 5min 24 seconds.

3. During the heating cycle the TEMP button will flash and the START/CANCEL button will be illuminated. The LCD panel will display the increasing temperature and the number of minutes and seconds remaining until the selected temperature is reached

4. The kettle will beep once when the selected water temperature has been reached.

Note: To cancel the heating process at any time during the boiling cycle, simply press the 'START/CANCEL' button once.

Note: If the kettle is removed from the power base during the heating process, the kettle will automatically reset, cancelling the heating cycle. However, when the kettle is replaced the Keep Warm function will remain illuminated if it was previously selected..

Time to Boil Feature

The Time to Boil feature calculates the amount of time remaining until the selected water temperature is reached.

Note: Water does not boil evenly and the amount of time it takes to boil is dependent on factors such as the volume of water, the ambient temperature, levels of mineral content and the selected temperature. Therefore, the Time to Boil is a guide only and is not scientifically exact.

When the heating cycle is initiated, the LCD display will show the maximum amount of time required to reach the selected water temperature. The Time to Boil shown on the LCD display will count down and flash until the correct amount of time is calculated. Once the correct time is calculated the Time to Boil may jump to the correct time remaining and will no longer flash.

Note: The Time to Boil feature does not calculate the remaining time before the temperature is reached when the initial temperature is 75°C and above.

Keep Warm Function

1. To maintain the temperature of the selected water temperature, simply press the **'KEEP WARM'** button. This will maintain the temperature selected for up to 20 minutes. The **'KEEP WARM'** button will remain illuminated to indicate that it has been selected.

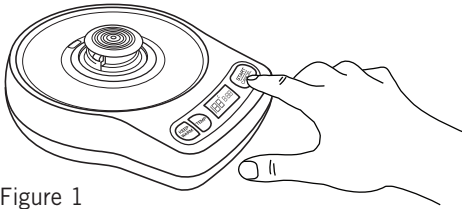

Figure 1

Note: The **'KEEP WARM'** button can be pressed when selecting your desired water temperature or after the power START/CANCEL button has been pressed (during the boiling cycle). It will then continue to flash during the heating cycle and will remain illuminated during the keep warm period. The **'KEEP WARM'** button will illuminate to indicate that it has been selected.

Note: If the **'KEEP WARM'** button is selected when the 100°C (boil) temperature has been selected, the kettle will boil to 100°C and maintain at 100°C for up to 20 minutes.

Note: If the kettle is removed from the power base during the keep warm period, the kettle will automatically resume the keep warm period at the set temperature when the kettle is replaced.

Note: During the heating cycle, the LCD display panel will remain illuminated, showing the temperature of the kettle as it increases and also the amount of time left before the kettle reaches the selected temperature.

Sleep mode

The kettle will automatically switch off the LCD screen after 20 minutes to save power. To exit the standby mode, press any button.

Note: If START/CANCEL is selected during Sleep Mode, the kettle will automatically initiate the previous settings (including temperature and Keep Warm).

Tea Brewing Styles and Tips

Optimum Tea Temperatures

The Variable Temperature Kettle has five optimum tea brewing temperatures 80°C, 85°C, 90°C, 95°C and 100°C (boil). Refer to the table below for Sunbeam's recommended temperature for a range of tea varieties:

OPTIMUM TEA TEMPERATURES							
GREEN TEAS - 80°C	Asatsutu	WHITE TEAS - 85°C	Apple	OOLONG TEAS - 90°C	China Rose	BLACK TEAS - 100°C	Assam
	Bancha		Blackcurrant		Darjeeling		Chai
	Ceylon Green		China Yin Zhen		Earl Grey		Chamomile
	China Chun		Elderflower		Ensemble		Cinnamon
	Mee		Ginger		Indian Chai		Herbal
	Green		Lemon		Irish		Lemongrass
	Dragon Well		Lychee		Breakfast		Peppermint
	Fukamushi		Orange		Keeman		Rooibos
	Sencha		Peony		Pouchong		Spearmint
	Gunpowder		Silver		Ti Kuan Yin		
	Gyokuro		Needle		Wuyi		
	Jasmine		Snowbud				
	Kukicha		Strawberry				
	Nepal Green			COFFEE - 90°C	Instant Coffee		
	Pi Lo Chun				Plunger Coffee		
	Sencha						
	Tencha						

Brew Strength and Time

The brew strength preference will vary from individual to individual, however we have provided below some suggested brew times dependant on how strong you like the flavour of your tea.

MILD	3 minutes
MEDIUM	4 minutes
STRONG	5 minutes

Note: Certain teas should not be brewed for more than 3 minutes, including certain green teas, white teas and oolong teas.

We recommend you read the packaging of your purchased tea variety for more detailed brewing instructions.

NOTE: These two tables are recommendations only and may vary depending on personal preference, brand and age of tea/coffee used.

Sunbeam's 3-Way Safety System



Safety is a major consideration in the design of a Sunbeam kettle. This is why we have developed our 3-Way Safety System, which ensures that your kettle will:

1. Automatically switch off after boiling.

For convenience, safety and energy efficiency, your Sunbeam kettle will automatically switch off after boiling.

2. Cut-out for boil-dry protection.

If the kettle is operated without water, it will automatically cut-out, preventing any damage to the element.

If this occurs, allow the kettle to cool before filling with cold water and re-boiling.

3. Shut-down in case of overheating.

In the event of overheating, the kettle will automatically shut down to prevent further damage. Should this occur, take your kettle to a Sunbeam Service Centre or Appointed Service Agent.

Care and Cleaning

Always disconnect the kettle from the power outlet before cleaning.

Never immerse the kettle switch area, cord or power base in water, or allow moisture to come into contact with these parts.

Descale Your Kettle Regularly

Mineral deposits in tap water solidify when the water is heated; lime scale may be white, coloured, even rusty-looking and is normally visible but phosphate scale isn't generally visible although may cause the water to appear cloudy when heated. This may cause the interior of the water gauge to discolour, cause overheating, trigger the boil-dry cut-out mechanism or even reduce the kettle's life.

Even in soft water areas it is important to descale your kettle regularly to help maintain its lifecycle.

To remove this build-up, use Sunbeam Liquid Descaler, a simple to use, non-toxic cleaner available from Sunbeam Appointed Service Agents.

Alternatively:

1. Fill the kettle with 3 cups of white vinegar and the remainder with water and allow to stand overnight. **DO NOT BOIL.**
2. Empty the solution from the kettle. Any stains remaining inside the spout can be removed by rubbing with a damp cloth. Fill the kettle with clean water, bring to boil and then discard the water. Repeat and the kettle will then be ready to use.

To clean the stainless exterior

The stainless steel surface may be wiped over with a damp cloth and polished with a soft dry cloth.

CAUTION: Do not use chemicals, steelwool, or abrasive cleaners to clean the outside of the kettle, as these will scratch the stainless steel surface.

To clean the mesh filter

Press the button on the handle to open the hinged lid. Grasp the top of the mesh filter and pull upwards to remove. Wash in warm soapy water and dry thoroughly before replacing in the kettle.



COMMERCIAL DESIGN GUARANTEED PERFORMANCE



The Sunbeam 2 Year Element Guarantee

Sunbeam has built its reputation on manufacturing quality electrical appliances. Our Cafe Series® Variable Temperature Kettle is constructed from the highest quality materials. So much so, we guarantee our Kettle element for (2) two years against faulty materials or manufacture. This guarantee is just another expression of our confidence in the way we make appliances at Sunbeam. In order to be eligible for this guarantee, you must retain your receipt as proof of purchase.

Your Cafe Series® Variable Temperature Kettle is covered for the first year against faulty material or manufacture by the Sunbeam 12 Month Replacement Guarantee. Should you experience any difficulties with your appliance within this 12 Month period, please phone our customer service line for advice on 1300 881 861 in Australia, or 0800 786 232 in New Zealand.

The Sunbeam (2) two year element guarantee begins from date of purchase and extends for one year beyond the 12 Month Replacement Guarantee. It covers only the element, guaranteeing it against faulty materials or manufacture. It does not cover damage caused by accident, misuse or being used in a manner not in accordance with the Instruction Book. Similarly, this element guarantee does not cover freight or any other costs incurred in making a claim.

If a fault should develop with the element after the period covered by the 12 Month Replacement Guarantee, please call Sunbeam Customer Service on the number listed below or send a written claim to Sunbeam at the address listed below. On receipt of your claim, Sunbeam will advise you on how to obtain a replacement element if your element is defective. Alternatively, you can return the Cafe Series® Variable Temperature Kettle to any of Sunbeam's authorised service centres, together with your receipt. The service centre will examine the element and if it is faulty or defective, the element will be replaced free of charge.

For a complete list of Sunbeam's authorised service centres visit our website or call:

Sunbeam Corporation Ltd. Australia

www.sunbeam.com.au
1300 881 861

Units 5 & 6, 13 Lord Street
Botany NSW 2019 Australia

Sunbeam Corporation Ltd. New Zealand

www.sunbeam.co.nz
0800 786 232

26 Vestey Drive, Mt Wellington
Auckland, New Zealand

The benefits given to you by this guarantee are in addition to your other rights and remedies under any laws which relate to the appliance.

Our goods come with guarantees that cannot be excluded under the Australian Consumer Law and under the New Zealand Consumer Guarantees Act. In Australia you are entitled to a replacement or refund for a major failure and for compensation for any other reasonably foreseeable loss or damage. You are also entitled to have the goods repaired or replaced if the goods fail to be of acceptable quality and the failure does not amount to a major failure.

IMPORTANT NOTE

Sunbeam agrees to replace the element in the event of the element developing a fault or defect, within the one year after the 12 Month Replacement Guarantee.

As your Cafe Series® Variable Temperature Kettle needs to be assessed at a Sunbeam authorised service centre, it will not be accepted through retail stores.

If using the Cafe Series® Variable Temperature Kettle for commercial use this element guarantee is limited to 12 months from the date of purchase.



COMMERCIAL DESIGN GUARANTEED PERFORMANCE

12 Month Replacement Guarantee

In the unlikely event that this appliance develops any malfunction within 12 months of purchase (3 months commercial use) due to faulty materials or manufacture, we will replace it for you free of charge.

Should you experience any difficulties with your appliance, please phone our customer service line for advice on 1300 881 861 in Australia, or 0800 786 232 in New Zealand. Alternatively, you can send a written claim to Sunbeam at the address listed below. On receipt of your claim, Sunbeam will seek to resolve your difficulties or, if the appliance is defective, advise you on how to obtain a replacement or refund.

Your Sunbeam 12 Month Replacement Guarantee naturally does not cover misuse or negligent handling and normal wear and tear.

Similarly your 12 Month Replacement Guarantee does not cover freight or any other costs incurred in making a claim. Please retain your receipt as proof of purchase.

The benefits given to you by this guarantee are in addition to your other rights and remedies under any laws which relate to the appliance.

Our goods come with guarantees that cannot be excluded under the Australian Consumer Law and under the New Zealand Consumer Guarantees Act.

In Australia you are entitled to a replacement or refund for a major failure and for compensation for any other reasonably foreseeable loss or damage. You are also entitled to have the goods repaired or replaced if the goods fail to be of acceptable quality and the failure does not amount to a major failure.

Should your appliance require repair or service after the guarantee period, contact your nearest Sunbeam service centre.

For a complete list of Sunbeam's authorised service centres visit our website or call:

Australia

www.sunbeam.com.au

1300 881 861

Units 5 & 6, 13 Lord Street
Botany NSW 2019 Australia

New Zealand

www.sunbeam.co.nz

0800 786 232

26 Vestey Drive, Mt Wellington
Auckland, New Zealand



COMMERCIAL DESIGN GUARANTEED PERFORMANCE

Need help with your appliance?

Contact our customer service team or visit our website for information and tips on getting the most from your appliance.

In Australia

Visit www.sunbeam.com.au

Or call 1300 881 861

In New Zealand

Visit www.sunbeam.co.nz

Or call 0800 786 232

Sunbeam is a registered trademark.

Cafe Series' logo and words are registered trademarks of Sunbeam Corporation.

Made in China.

Due to minor changes in design or otherwise, the product may differ from the one shown in this leaflet.

© Copyright. Sunbeam Corporation Limited 2006.

ABN 45 000 006 771

Sunbeam Corporation is a division of GUD Holdings Ltd.

Units 5 & 6, 13 Lord Street
Botany NSW 2019 Australia

Unit 3, Building D
26 Vestey Drive
Mt Wellington Auckland
New Zealand