

HBC84K553A



**BOSCH**

[en] Instruction manual .....2



9000590620

<b>Safety precautions</b> .....	<b>2</b>	<b>Automatic switch-off</b> .....	<b>12</b>
Before installation .....	2	<b>Care and cleaning</b> .....	<b>12</b>
Safety notes .....	2	Cleaning agents .....	12
Information on the microwave .....	3	Cleaning the glass panels .....	13
Causes of damage .....	4	Cleaning the glass cover .....	13
<b>Your new appliance</b> .....	<b>4</b>	<b>Malfunction table</b> .....	<b>14</b>
Control panel .....	5	Malfunction table.....	14
Buttons and display.....	5	Replacing the oven light bulb .....	15
Temperature selector.....	5	Replacing the door seal.....	15
Function selector.....	5	<b>After-sales service</b> .....	<b>15</b>
Cooking compartment .....	5	E number and FD number .....	15
Accessories .....	6	<b>Energy and environment tips</b> .....	<b>16</b>
<b>Before using the appliance for the first time</b> .....	<b>7</b>	Saving energy.....	16
Setting the clock .....	7	Environmentally-friendly disposal.....	16
Heating up the oven.....	7	<b>Automatic programmes</b> .....	<b>16</b>
Cleaning the accessories.....	7	Making settings.....	16
<b>Setting the oven</b> .....	<b>7</b>	Defrosting and cooking with the automatic programmes .....	17
Type of heating and temperature .....	7	<b>Tested for you in our cooking studio</b> .....	<b>19</b>
<b>The microwave</b> .....	<b>7</b>	Defrosting, heating up and cooking with the microwave.....	19
Notes regarding ovenware.....	7	Microwave tips .....	22
Microwave power settings.....	8	Cakes and pastries .....	22
Setting the microwave.....	8	Baking tips .....	23
<b>Microwave combi operation</b> .....	<b>8</b>	Roasting and grilling .....	24
Setting Microwave Combi operation .....	8	Tips for roasting and grilling.....	27
<b>1, 2, 3 series of operations</b> .....	<b>9</b>	Bakes, gratins, toast with toppings .....	27
Setting a series of operations .....	9	Convenience products.....	28
<b>Setting the time-setting options</b> .....	<b>9</b>	<b>Test dishes</b> .....	<b>28</b>
Timer .....	9	Baking .....	29
Cooking time .....	9	Grilling.....	29
End time .....	10	<b>Acrylamide in foodstuffs</b> .....	<b>29</b>
Clock .....	10		
<b>Childproof lock</b> .....	<b>11</b>		
Switching on the childproof lock .....	11		
Switching off the childproof lock.....	11		
Childproof lock with automatic programmes .....	11		
<b>Changing the basic settings</b> .....	<b>11</b>		

Additional information on products, accessories, replacement parts and services can be found at [www.bosch-home.com](http://www.bosch-home.com) and in the online shop [www.bosch-eshop.com](http://www.bosch-eshop.com)

## Safety precautions

Please read this instruction manual carefully. Only then will you really be able to operate your appliance safely and correctly.

Please keep the instructions for use and installation instructions in a safe place. Please pass on these manuals to the new owner if you sell the appliance.

### Before installation

#### Damage during transport

Check the appliance for damage after unpacking it. Do not connect the appliance if it has been damaged in transit.

#### Electrical connection

Only a licensed expert may connect the appliance. You will lose your warranty entitlement in the event of any damage caused by incorrect connection.

### Installation and connection

Please observe the special installation instructions.

### Safety notes

This appliance is intended for domestic use only. This appliance must only be used for food preparation.

Adults and children must not operate the appliance without supervision,

- if they are physically or mentally incapable of doing so or
- if they have insufficient knowledge or experience.

Never let children play with the appliance.

### Hot cooking compartment

#### Risk of burns!

- Never touch the hot surfaces of heating and cooking appliances. Never touch the internal surfaces of the cooking

compartment or the heating elements. Open the cooking compartment door carefully. Hot steam may escape. Small children must be kept at a safe distance from the appliance at all times.

- Never prepare food containing large quantities of drinks with a high alcohol content. Alcoholic vapours can catch fire in the cooking compartment. Use only small quantities of drinks with a high alcohol content and open the cooking compartment door carefully.

#### **Risk of fire!**

- Never store combustible items in the cooking compartment. Never open the appliance door if there is smoke inside. Switch off the appliance. Pull out the mains plug or switch off the circuit breaker in the fuse box.
- Do not place greaseproof paper loosely over accessories during preheating. A draught is created when the appliance door is opened. The greaseproof paper may come into contact with the heating element and catch fire. Always weight down the greaseproof paper with a dish or a baking tin. Only cover the surface required with greaseproof paper. The greaseproof paper must not protrude over the accessories.

#### **Risk of short circuit!**

Never trap connecting cables of electrical appliances in the hot appliance door. The cable insulation could melt.

#### **Risk of scalding!**

Never pour water into the hot cooking compartment. This will produce hot steam.

#### **Hot accessories and ovenware**

##### **Risk of burns!**

Never remove ovenware or accessories from the cooking compartment without an oven cloth or oven gloves.

#### **Damaged cooking compartment door or door seal**

##### **Risk of serious damage to health.!**

Never use the appliance if the cooking compartment door or the door seal is damaged. Microwave energy may escape. Only use the appliance again once it has been repaired.

#### **Heavily corroded surfaces**

##### **Risk of serious damage to health.!**

The surface of the appliance could rust through over time if it is not cleaned properly. Microwave energy may escape. Clean the appliance on a regular basis.

#### **Casing open**

##### **Risk of electric shock!**

Never remove the casing. The appliance is a high-voltage appliance.

##### **Risk of serious damage to health.!**

Never remove the casing. It prevents microwave energy from escaping.

#### **Hot or humid environment**

##### **Risk of short circuit!**

Never subject the appliance to intense heat or humidity.

#### **Improper repairs**

##### **Risk of electric shock!**

- Incorrect repairs are dangerous. Repairs may only be carried out and damaged power cables replaced by one of our trained after-sales technicians.

- If the appliance is faulty, switch off the circuit breaker in the fuse box or disconnect the appliance at the mains. Call the after-sales service.

## **Information on the microwave**

### **Preparing food**

#### **Risk of fire!**

Only use the microwave to prepare food which is fit for consumption. Using the microwave for other purposes may be dangerous and may result in damage, e.g. heated slippers and grain or cereal pillows could catch fire, even several hours later.

### **Ovenware**

#### **Risk of injury!**

- Porcelain or ceramic ovenware can have small perforations in the handles or lids. These perforations conceal a cavity below. Any moisture that penetrates this cavity could cause the ovenware to crack.
- Only use ovenware that is suitable for use in a microwave.

#### **Risk of burns!**

Hot food can heat up ovenware. Always use an oven cloth or oven gloves to remove ovenware and accessories from the cooking compartment.

### **Microwave power and time**

#### **Risk of fire!**

Do not select a microwave power or time setting that is higher than necessary. The food could catch fire and cause damage to the appliance. Follow the information provided in this instruction manual.

### **Packaging**

#### **Risk of fire!**

- Never heat food in heat-retaining packages.
- Do not leave food heating unattended in containers made of plastic, paper or other combustible materials.

#### **Risk of burning!**

Airtight packaging may burst when food is heated. Follow the information provided on the packaging. Always use an oven cloth or oven gloves to remove meals.

### **Drinks**

#### **Risk of scalding!**

There is a possibility of delayed boiling when a liquid is heated. This means that the liquid reaches boiling temperature without the usual steam bubbles rising to the surface. Even if the container only vibrates a little, the hot liquid can suddenly boil over and spatter. When heating liquids, always place a spoon in the container. This will prevent delayed boiling.

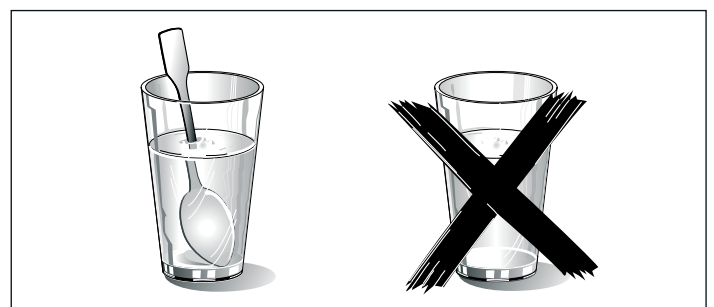

#### **Risk of explosion!**

- Never heat drinks in containers that have been tightly sealed.
- Never overheat alcoholic drinks.

## **Baby food**

### **Risk of burns!**

Never heat baby food in closed containers. Always remove the lid or teat. Stir or shake well after the food has been heated. This is the only way to ensure even heat distribution. Check the temperature of the food before it is given to the child.

## **Foods with shells or skin**

### **Risk of burns!**

- Never cook eggs in their shells. Never reheat hard-boiled eggs as they may crack or explode. The same applies to shellfish and crustaceans. Always prick the yoke when baking or poaching eggs.
- Always prick the skin of foods that have a skin or peel such as apples, tomatoes, potatoes and sausages before cooking, to prevent the peel or skin from bursting.

## **Drying food**

### **Risk of fire!**

Never use the microwave to dry food.

## **Food with a low water content**

### **Risk of fire!**

Never defrost or heat food with a low water content, e.g. bread, at too high a power or for too long.

## **Cooking oil**

### **Risk of fire!**

Never use the microwave to heat cooking oil on its own.

## **Causes of damage**

### **Caution!**

- Creation of sparks. Metal - e.g. a spoon in a glass - must be kept at least 2 cm from the oven walls and the inside of the door. Sparks could irreparably damage the glass on the inside of the door.
- Baking tray, greaseproof paper, aluminium foil or ovenware on the cooking compartment floor. Do not place baking trays or ovenware on the cooking compartment floor. Do not line

the cooking compartment floor with aluminium foil. This will cause heat accumulation. The baking and roasting times will no longer be correct and the enamel will be damaged.

- Foil containers. Do not use foil containers in the appliance. They damage the appliance by producing sparks.
- Water in the hot cooking compartment. Never pour water into the hot cooking compartment. This will cause steam. The temperature change can cause damage to the enamel.
- Moist food. Do not store moist food in the closed cooking compartment for long periods. This will damage the enamel. Do not use the appliance to store food. This can lead to corrosion.
- Fruit juice. When cooking very moist fruit flans, do not fill the universal pan too generously. Fruit juice which runs out of the universal pan leaves behind stains which cannot be removed.
- Cooling with the appliance door open. Only leave the cooking compartment to cool with the door closed. Do not trap anything in the appliance door. Even if the door is only slightly ajar, the fronts of adjacent units may be damaged over time.
- Heavily soiled seal. If the seal is very dirty, the appliance door will no longer close properly during operation. The fronts of adjacent units could be damaged. Always keep the seal clean.
- Using the appliance door for standing on or placing objects on. Do not stand or place anything on the open appliance door. Do not place ovenware or accessories on the appliance door.
- Transporting the appliance. Do not carry or hold the appliance by the door handle. The door handle cannot support the weight of the appliance and could break.
- Operating the microwave without food. The microwave must only be switched on when there is food in the cooking compartment. The appliance may be overloaded if it is switched on without any food inside. An exception to this rule is for short-term testing of ovenware (see notes on ovenware).
- Microwave popcorn. Never set the microwave power too high. Use a power setting no higher than 600 watts. Always place the popcorn bag on a glass plate. The disc may jump if overloaded.

---

# **Your new appliance**

Use this section to familiarise yourself with your new appliance. The control panel and the individual operating controls are explained. You will find information on the cooking compartment and the accessories.

## Control panel

Here is an overview of the control panel. Depending on the appliance model, there may be differences in the particular details.

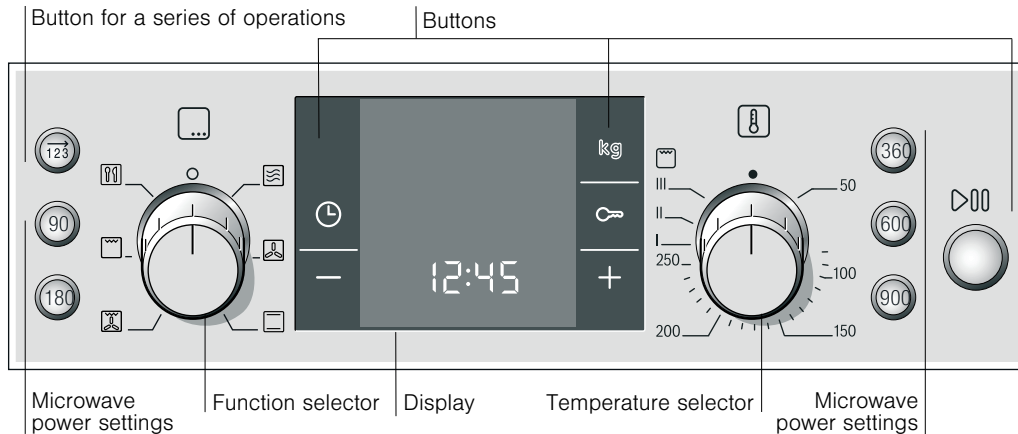

### Control knobs

The control knobs are retractable. To lock it in or out, press the control knob in the off position.

### Buttons

The sensors are located under the individual buttons. They must not be pressed too firmly. Only touch the corresponding symbol.

Exception: the button for the series of operations and the buttons for the microwave power settings are normal push buttons.

### Buttons and display

Using the buttons, you can set various functions. You can check the values that you have set in the display.

Button	Use
123	Selects a series of operations
90	Selects 90 watt microwave power setting
180	Selects 180 watt microwave power setting
360	Selects 360 watt microwave power setting
600	Selects 600 watt microwave power setting
900	Selects 900 watt microwave power setting
kg	Kilogrammes Selects the kilogrammes for the programmes.
⌚	Time-setting options Selects the ⌚ timer, ⌚ cooking time, ⌚ end time and ⌚ clock.
-	Minus Decreases the set values.
+	Plus Increases the set values.
▶⏸	Start/Pause Press briefly = starts/stops operation Press and hold = cancels operation

Which time-setting option is shown on the display is indicated by the brackets [ ] around the corresponding symbol.  
Exception: for the clock, the ⌚ symbol only lights up when you make changes.

### Temperature selector

The temperature selector is used to set the temperature or grill setting.

Setting	Meaning
●	Off position The oven does not heat up.
50-250	Temperature range The temperature in the oven in °C.
I, II, III	Grill settings The grill settings for the 🍷 Grill. I = setting 1, low II = setting 2, medium III = setting 3, high

The 🍷 symbol remains lit in the display until the oven has reached the set temperature. The symbol does not light up when grilling.

### Function selector

Use the function selector to set the type of heating.

Setting	Use
○	Off position The oven is switched off.
🍷	Microwave mode For setting the microwave power levels.
🍷	Hot air For baking sponge cakes in baking tins on one level.
🍷	Top/bottom heating For baking and roasting on one level. Especially suitable for cakes with moist toppings (e.g. cheesecake).
🍷	Hot air grilling For poultry and larger pieces of meat.
🍷	Grill For large amounts of flat, small items for grilling (e.g. steaks, sausages).
🍷	Programmes 5 defrosting programmes 15 cooking programmes The type of heating and cooking time are set by weight.

### Cooking compartment

Your appliance has a cooling fan.

#### Cooling fan

The cooling fan switches on and off as required. The hot air escapes above the door.

#### Caution!

do not cover the ventilation slots. Otherwise the oven will overheat.

## Notes

- The cooling fan continues to run for a certain time after operation.
- The appliance remains cool during microwave operation. The cooling fan will still switch on. The fan may run on even when microwave operation has ended.
- Condensation may appear on the door window, interior walls and floor. This is normal and does not adversely affect microwave operation. Wipe away the condensation after cooking.

The light in the cooking compartment only switches on after the  button is pressed.

## Accessories

The accessories can be inserted into the oven at 3 different levels.

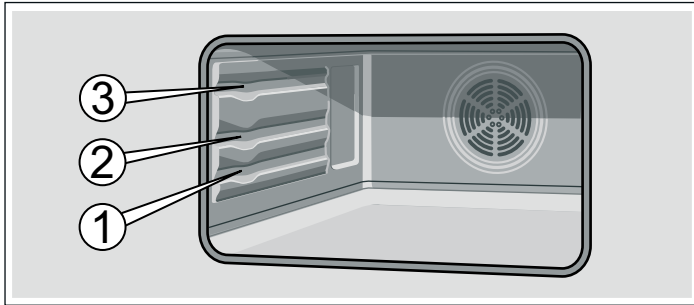

The accessories can become deformed when they become hot. As soon as they have cooled down, the deformation disappears with no effect on the function.

Accessories may be purchased at a later date from the after-sales service or from specialist shops. Please quote the HEZ/HMZ number.

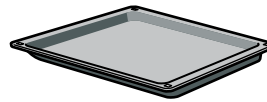

### Universal pan HEZ862000

For large roasts, dry and moist cakes, bakes and gratins. It can also act as a splashguard if you are grilling meat directly on the wire rack. To do this, insert the universal pan at level 1.

Insert the universal pan into the oven with the tapered edge facing the oven door.



### Glass pan HEZ863000

For large roasts, dry and moist cakes, bakes and gratins. This can act as a splash guard if you are grilling meat directly on the wire rack. For this, slide the glass pan in at level 1.

The glass pan can also be used as a standing surface during microwave operation.

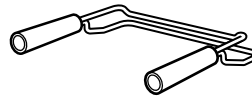

### Handle

For removing the glass pan.

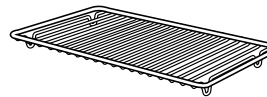

### Wire rack

For grilling. Always place the wire rack in the glass pan.

Fat and meat juices are collected.

## Special accessories

You can purchase special accessories from the after-sales service or specialist shops.

You will find a comprehensive range of products for your oven in our brochures and on the Internet.

The availability of special accessories and whether it is possible to order them online may vary depending on your country. Please see the sales brochures for more details

Special accessories	HEZ number	Usage
Enamel baking tray	HEZ861000	For cakes and biscuits. Push the baking tray as far as possible into the oven, with the sloping edge facing towards the oven door
Glass roasting dish	HEZ915001	For braised dishes and bakes that are cooked in the oven. This is particularly suitable for automatic programs.

## After-sales service products

You can obtain suitable care and cleaning agents and other accessories for your domestic appliances from the after-sales

service, specialist retailers or (in some countries) online via the e-Shop. Please specify the relevant product number.

Cleaning cloths for stainless-steel surfaces	Product no. 311134	Reduces the build-up of dirt. Impregnated with a special oil for perfect maintenance of your appliance's stainless-steel surfaces.
Oven and grill cleaning gel	Product no. 463582	For cleaning the cooking compartment. The gel is odourless.
Microfibre cloth with honeycomb structure	Product no. 460770	Especially suitable for cleaning delicate surfaces, such as glass, glass ceramic, stainless steel or aluminium. The microfibre cloth removes liquid and grease deposits in one go.
Door lock	Product no. 612594	To prevent children from opening the oven door. The locks on different types of appliance door are screwed in differently. See the information sheet supplied with the door lock.

# Before using the appliance for the first time

Here you will find everything you need to do before using your oven to prepare food for the first time. First read the section on *Safety information*.

## Setting the clock

After the appliance has been connected, the ⌚ symbol and four zeros light up in the display. Set the clock.

1. Press the ⌚ button.

The time 12:00 is shown in the display.

2. Use the + or - button to set the clock.

After a few seconds, the time that has been set is adopted.

## Heating up the oven

To remove the new cooker smell, heat up the oven when it is empty and closed. One hour of □ Top/bottom heating at 240 °C is ideal for this. Ensure that no packaging remnants have been left in the cooking compartment.

1. Use the function selector to set □ Top/bottom heating.
2. Set the temperature selector to 240 °C.
3. Press the ▶ button.

After an hour, switch off the oven. To do so, turn the function selector to the off position.

## Cleaning the accessories

Before you use the accessories for the first time, clean them thoroughly with hot soapy water and a soft dish cloth.

# Setting the oven

There are various ways in which you can set your oven. Here we will explain how you can select the desired type of heating and temperature or grill setting. You can select the oven cooking time and end time for your dish. Please refer to the section on *Setting the time-setting options*.

## Type of heating and temperature

Example in diagram: □ Top/bottom heating at 190 °C.

1. The function selector is used to set the type of heating.

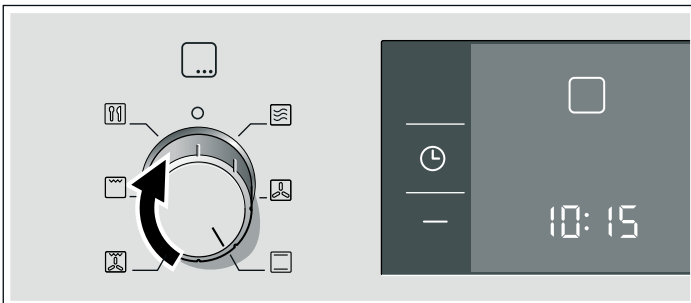

2. The temperature selector is used to set the temperature or grill setting.

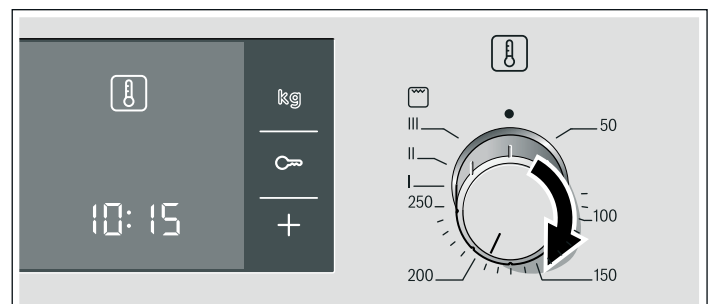

3. Press the ▶ button.

The oven begins to heat up.

## Switching off the oven

Turn the function selector to the off position.

## Changing the settings

The type of heating and temperature or grill setting can be changed at any time using their respective selectors.

# The microwave

Microwaves are converted to heat in foodstuffs. The microwave can be used solo, i.e. on its own, or in combination with a different type of heating. You will find information about ovenware and how to set the microwave.

### Note.

In the *Tested for you in our cooking studio* section, you will find examples for defrosting, heating and cooking with the microwave oven.

## Notes regarding ovenware

### Suitable ovenware

Suitable dishes are heat-resistant ovenware made of glass, glass ceramic, porcelain, ceramic or heat-resistant plastic. These materials allow microwaves to pass through.

You can also use serving dishes. This saves you having to transfer food from one dish to another. You should only use ovenware with decorative gold or silver trim if the manufacturer guarantees that they are suitable for use in microwaves.

### Unsuitable ovenware

Metal ovenware is unsuitable. Metal does not allow microwaves to pass through. Food in covered metal containers will remain cold.

### Caution!

Creation of sparks: metal – e.g. a spoon in a glass – must be kept at least 2 cm from the oven walls and the inside of the door. Sparks could destroy the glass on the inside of the door.

## Ovenware test

Do not switch on the microwave unless there is food inside. The following ovenware test is the only exception to this rule.

Perform the following test if you are unsure whether your ovenware is suitable for use in the microwave:

1. Heat the empty ovenware at maximum power for ½ to 1 minute.
2. Check the temperature occasionally during that time. The ovenware should still be cold or warm to the touch. The ovenware is unsuitable if it becomes hot or sparks are generated.

## Microwave power settings

Use the button to set the desired microwave power.

90 W	for defrosting delicate foods
180 W	for defrosting and continued cooking
360 W	for cooking meat and heating delicate foods
600 W	for heating and cooking food
900 watts	for heating liquids

### Notes

- When you press a button, the selected power lights up.
- The microwave power can be set to 900 watts for a maximum of 30 minutes. With all other power settings a maximum cooking time of 1 hour 30 minutes is possible.

## Setting the microwave

Example: Microwave power 600W, cooking time 17 minutes.





1. Set the function selector to .
2. Press the button for the microwave power setting you require.

# Microwave combi operation

This involves the simultaneous operation of one type of heating with the microwave. This allows you to prepare dishes such as meat loaf, for example. If you switch on the microwave function, the meat loaf will be ready more quickly.

You can switch on all microwave power settings. Exception: 900 watts

### Suitable types of heating

-  Hot air
-  Top/bottom heat
-  Hot air grilling
-  Grill

## Setting Microwave Combi operation

Example: Microwave 360 W, 17 minutes and  Hot air 190 °C.

1. Set the type of heating using the function selector, and the temperature using the temperature selector.
2. Press the button for the microwave power setting you require. A suggested cooking time appears.
3. Use the + or – button to set the cooking time.
4. Press the  button.

Operation begins. The cooking time starts counting down.

### The cooking time has elapsed

A signal sounds. Combination mode has finished. You can stop the audible signal by pressing the  button.

The 600 W power level lights up and a suggested cooking time is displayed.

3. Use the + or – button to set the cooking time.
4. Press the  button.

Operation begins. The cooking time starts counting down.

### The cooking time has elapsed

A signal sounds. Microwave operation has finished. Turn the function selector to the zero position. You can stop the audible signal by pressing the  button.

### Opening the oven door during cooking

Operation is suspended. After closing the door, press the  button briefly. The programme will then continue.

### Changing the cooking time

This can be done at any time. Use the + or – button to change the cooking time.

### Changing the microwave power setting

Press the button for the new microwave power setting. Use the + or – button to set the cooking time and restart the microwave.

### Cancelling operation

Press and hold the  button for approximately 4 seconds and turn the function selector to the off position.



### Notes

- When you set the function selector to , the highest microwave power setting always lights up as the suggested setting.
- If you open the appliance door during cooking, the fan may continue to run.

### Opening the oven door during cooking

Operation is suspended. After closing the door, press the  button briefly. The programme will then continue.

### Pausing operation

Press the  button briefly. The oven is paused. Press the  button again to continue operation.

### Changing the cooking time

This can be done at any time. Use the + or – button to change the cooking time.

### Changing the microwave power setting

Press the button for the new microwave power setting. Use the + or – button to set the cooking time and restart the microwave.

### Cancelling operation

Press and hold the  button for approximately 4 seconds or turn the function selector and temperature selector back to the off position.



---

# 1, 2, 3 series of operations









You can use the SeriesOperations function to set up to three different microwave power settings and times and then start.

## Ovenware

Always use microwave-safe, heat-resistant ovenware.

## Setting a series of operations

Set a cooking time for each operation in the series.

1. Set the function selector to .
2. Press the  button.  
The  for the first operation in the series appears on the display.
3. Set the first microwave power setting and cooking time.
4. Press the  button.  
The  for the second operation in the series appears.
5. Set the second microwave power setting and cooking time.
6. Press the  button.  
The  for the third operation in the series appears.
7. Set the third microwave power setting and cooking time.
8. Press the  button.

Operation begins. The first step in the series of operations appears in the display. The cooking time starts counting down.

## The cooking time has elapsed

A signal sounds. The series of operations is finished. You can stop the audible signal by pressing the  button.



## Changing the setting

Changes can only be made before operation begins. Press the  button repeatedly until the number for the series of operations appears. Change the setting.

## Opening the oven door during cooking

Operation is suspended. After closing the door, press the  button briefly. The programme will then continue.

## Pausing operation

Press the  button briefly. The oven is paused. Press the  button again to continue operation.

## Cancelling operation

Press and hold the  button for approximately 4 seconds or turn the function selector to the off position.

## Calling up the cooking time

Press the  button once.

## Note.

You can also combine a type of heating with the series of operations. Set the type of heating first.



---

# Setting the time-setting options

Your oven has various time-setting options. You can use the  button to call up the menu and switch between the individual functions. All the time symbols are lit when you can make settings. The brackets [ ] show you which time-setting option you have currently selected. A time-setting option which has already been set can be changed directly with the **+** or **-** button when the relevant time symbol is in brackets.

## Timer

You can use the timer as a kitchen timer. It runs independently of the oven. The timer has its own signal. In this way, you can tell whether it is the timer or a cooking time which has elapsed.

1. Press the  button once.  
The time symbols light up in the display and the brackets are around .
2. Use the **+** or **-** button to set the timer duration.  
Default value for **+** button = 10 minutes  
Default value for **-** button = 5 minutes

After a few seconds, the time setting is adopted. The timer starts. The [] symbol lights up in the display and the timer duration counts down. The other time symbols go out.

## The timer duration has elapsed

A signal sounds. 00:00 is shown in the display. Use the  button to switch off the timer.

## Changing the timer duration





Use the **+** or **-** button to change the timer duration. After a few seconds, the change is adopted.

## Cancelling the timer duration

Use the **-** button to reset the timer duration to 00:00. The change will be adopted after a few seconds. The timer is switched off.

## Checking the time settings

If several time-setting options are set, the relevant symbols are illuminated on the display. The symbol for the time-setting option that is visible in the display is shown in brackets.

To call up the  timer,  cooking time,  end time or  clock, press the  button repeatedly until the brackets are around the relevant symbol. The display shows the value for a few seconds.

## Cooking time

The cooking time for your meal can be set on the oven. When the cooking time has elapsed, the oven switches off automatically. This means that you do not have to interrupt other work to switch off the oven. The cooking time is not accidentally exceeded.

Example in the picture: Cooking time 45 minutes.

1. The function selector is used to set the type of heating.
2. The temperature selector is used to set the temperature or grill setting.
3. Press the  button twice.

00:00 appears in the display. The time symbol lights up, and the brackets are around .

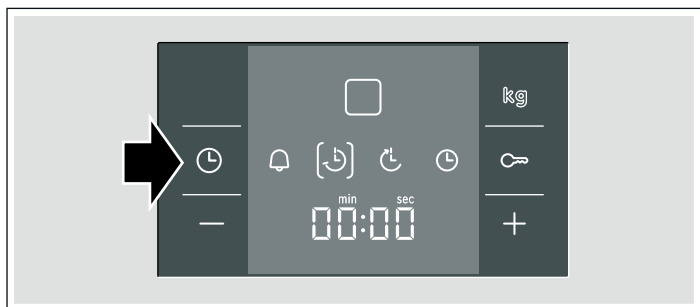

4. Use the **+** or **-** button to set the cooking time.

Default value for the **+** button = 30 minutes  
Default value for the **-** button = 10 minutes



5. Press the  button.

The cooking time starts counting down in the display and the  symbol lights up. The other time symbols go out.

#### The cooking time has elapsed

An audible signal sounds. The oven stops heating. 00:00 is shown in the display. Press the  button. The audible signal stops. Turn the function selector to the off position. The oven is switched off.

#### Changing the cooking time





Use the **+** or **-** button to change the cooking time. After a few seconds, the change is adopted. If the timer has been set, press the  button beforehand.

#### Cancelling the cooking time

Use the **-** button to reset the cooking time to 00:00. After a few seconds, the change is adopted. The cooking time is cancelled. If the timer has been set, press the  button beforehand.

#### Checking the time settings

If several time-setting options are set, the relevant symbols are illuminated on the display. The symbol for the time-setting option that is visible in the display is shown in brackets.

To call up the  timer,  cooking time,  end time or  clock, press the  button repeatedly until the brackets are around the relevant symbol. The display shows the value for a few seconds.

#### End time

You can change the time at which you wish your meal to be ready. The oven starts automatically and finishes at the desired time. You can, for example, put your meal in the cooking compartment in the morning and set the cooking time so that it is ready at lunch time.

Ensure that food is not left in the cooking compartment for too long as it may spoil.

Example in the diagram: it is 10:30 am, the cooking time is 45 minutes and the oven is set to finish cooking at 12:30pm.

1. Set the function selector.

2. Set the temperature selector.

3. Press the  button twice.

4. Use the **+** or **-** button to set the cooking time.

5. Press the  button.



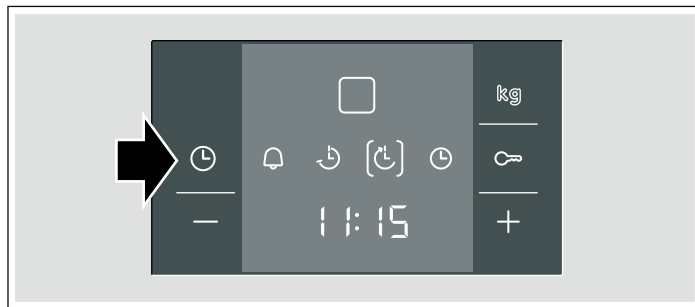

The brackets are shown around . The time when the dish will be ready is displayed.





6. Use the **+** or **-** button to set a later end time.



7. Press the  button.

The oven switches to standby. The time at which the dish will be ready is shown in the display and the  symbol is shown in brackets. The  and  symbols go out. When the oven starts, the cooking time starts counting down and the  symbol is shown in brackets. The  symbol goes out.

#### The cooking time has elapsed

A signal sounds. The oven stops heating. 00:00 is shown in the display. Press the  button. You can set a new cooking time using the **+** or **-** button. Or press the  button twice and turn the function selector to the off position. The oven switches off.

#### Changing the end time





Use the **+** or **-** button to change the end time. After a few seconds, the change is adopted. If the timer has been set, first press the  button twice. Do not change the end time if the cooking time has already started to elapse. The cooking result would no longer be correct.

#### Cancelling the end time

Use the **-** button to reset the end time to the current time. After a few seconds, the change is adopted. The oven starts. If the timer has been set, first press the  button twice.

#### Checking the time settings

If several time-setting options are set, the relevant symbols are illuminated on the display. The symbol for the time-setting option that is visible in the display is shown in brackets.

To call up the  timer,  cooking time,  end time or  clock, press the  button repeatedly until the brackets are around the relevant symbol. The display shows the value for a few seconds.

#### Clock

After the appliance is connected or following a power cut, the  symbol and four zeros light up in the display. Set the clock.

1. Press the  button.

The time 12:00 is shown in the display.

2. Use the **+** or **-** button to set the clock.

After a few seconds, the time that has been set is adopted.

### Changing the clock

No other time-setting option should have been set.

1. Press the  button four times.

The time symbols light up in the display and the brackets are around .

2. Use the **+** or **-** button to change the clock.

After a few seconds, the time that has been set is adopted.

### Hiding the clock

You can hide the clock. For more information, please refer to the section *Changing the basic settings*.

## Childproof lock

The oven has a childproof lock to prevent children switching it on accidentally.

The oven will not react to any settings. The timer and clock can also be set when the childproof lock has been switched on.

### Switching on the childproof lock

Requirement: No cooking time should be set and the function selector is in the zero position.

Press and hold the  button for approx. four seconds.

The  symbol appears in the display. The childproof lock is switched on.

### Switching off the childproof lock

Press and hold the  button for approx. four seconds.

The  symbol on the display goes out. The childproof lock is switched off.

### Childproof lock with automatic programmes

When automatic programmes have been set, the childproof lock is not operational.

## Changing the basic settings



Your oven has various basic settings. These settings can be customised to suit your requirements.

Basic setting	Selection 0	Selection 1	Selection 2	Selection 3
<b>c0</b> Brightness of the display lighting	-	night	medium*	day
<b>c1</b> <b>Cooking time signal</b> The duration of the audible signal once a cooking time has elapsed.	-	approx. 10 seconds	approx. 2 minutes*	approx. 5 minutes
<b>c2</b> <b>Clock display</b> The clock is shown in the display if the oven is switched off.	only when in operation*	always*	-	-
<b>c3</b> <b>Continue operation</b> Way in which operation continues once the oven door has been opened and closed again.  Continue when door shut: off *Continue operation with 	off*	automatic	-	-
<b>c4</b> <b>Waiting time until a setting is applied</b>	-	approx. 2 seconds	approx. 5 seconds*	approx. 10 seconds
<b>c5</b> <b>Operating voltage</b>	220-230 V*	230-240 V	-	-
<b>c6</b> <b>Reset factory settings</b> Revert all changes to the basic settings.	no*	yes	-	-

\* Factory setting

### The oven must be switched off.

1. Press and hold the  button for approx. 4 seconds.

The current basic setting for signal duration is shown on the display, e.g.   for selection 2.

2. Use the **+** or **-** button to change the basic setting.

3. Confirm by pressing the  button.

The next basic setting appears in the display. You can scroll through all levels using the  button and change the setting using the **+** or **-** button.

4. To finish, press and hold the  button for approx. 4 seconds.

All basic settings are applied.

You may change the basic settings at any time.

# Automatic switch-off

If you do not change the settings on your appliance for several hours, automatic switch-off is activated. The oven stops heating. The point at which this occurs depends on the temperature or grill setting that has been set.

## Automatic switch-off is activated

A signal sounds. F8 appears in the display. The oven stops heating.

Turn the function selector to the off position. The oven switches off.

## Overriding automatic switch-off

So that automatic switch-off is not activated when it is not wanted, you can set a time period. The oven will heat until this period has expired.

# Care and cleaning

With careful care and cleaning your microwave oven will retain its looks and remain good order. We will explain here how you should care for and clean your appliance correctly.

## Risk of short circuit!

Never use high-pressure cleaners or steam cleaners to clean the oven.

## Risk of burns!

Never clean the appliance immediately after switching off. Let the appliance cool down.

## Notes

- Slight differences in colour on the front of the appliance are caused by the use of different materials, such as glass, plastic and metal.
- Shadows on the door panel which look like streaks, are caused by reflections made by the oven light.
- Enamel is baked on at very high temperatures. This can cause some slight colour variations. This is normal and does not affect their function. The edges of thin trays cannot be completely enamelled. As a result, these edges can be rough. This will not impair the anti-corrosion protection.
- Unpleasant odours, e.g. after fish has been prepared, can be removed very easily. Add a few drops of lemon juice to a cup of water. Place a spoon into the container as well, to prevent delayed boiling. Heat the water for 1 to 2 minutes at maximum microwave power.

## Cleaning agents

To ensure that the different surfaces are not damaged by using the wrong cleaning agent, observe the information in the table. Do not use

- sharp or abrasive cleaning agents,
- metal or glass scrapers to clean the glass in the appliance door,
- metal or glass scrapers to clean the door seal,
- hard scouring pads and sponges,
- cleaning agents with high concentrations of alcohol.

Wash new sponge cloths thoroughly before use.

Area	Cleaning agents
Appliance front	Hot soapy water: Clean with a dish cloth and dry with a soft cloth. Do not use glass cleaners or metal or glass scrapers for cleaning.
Stainless steel	Hot soapy water: Clean with a dish cloth and dry with a soft cloth. Remove flecks of limescale, grease, starch and albumin (e.g. egg white) immediately. Corrosion can form under such residues. Special stainless steel cleaning agents can be obtained from the after-sales service or from specialist shops.
Oven	Hot soapy water or a vinegar solution: Clean with a dish cloth and dry with a soft cloth. If oven is very dirty: use oven cleaner, but only when oven is cold. It is best to use a stainless-steel sponge.
Glass cover for the oven light	Hot soapy water: Clean with a dish cloth.
Control panel/outer door panel	Glass cleaner: Wipe dry immediately using a soft cloth. Do not use a glass scraper.
Inner door glass	Glass cleaner: Wipe dry with a soft cloth. Do not use a glass scraper.
Seal	Hot soapy water: Clean with a dish cloth, do not scour. Do not use a metal or glass scraper for cleaning.
Accessories	Hot soapy water: Soak and clean with a dish cloth or a brush.

## Self-cleaning surface in the cooking compartment

The back panel of the oven is coated with self-cleaning enamel. It cleans itself while the oven is in operation. Sometimes, larger splashes of food may not disappear until the oven has been operated several times.

## Notes

- Never treat the self-cleaning surface with oven cleaner. If oven cleaner accidentally gets onto the rear wall, remove it immediately with a sponge and plenty of water.
- Never use abrasive cleaning agents. You will scratch or destroy the highly porous coating.
- Never clean the self-cleaning surface with a scouring pad.
- Light discolouration of the enamel does not affect self-cleaning.

## Cleaning the cooking compartment floor, ceiling and side walls

Use a dish cloth and hot soapy water or a vinegar solution. It is best to use oven cleaner if there are very heavy deposits of dirt. Only use oven cleaner in a cold oven.

## Cleaning the glass panels

The glass panels can be removed from the oven door for cleaning.

### ⚠ Risk of burns!

Do not remove the panels immediately after switching the appliance off. The oven must be cold.

### Removal

1. Open the oven door.
2. Undo the two screws on the door using a flat-bladed screwdriver (blade width 8-11 mm). Hold the door panel firmly while doing this. (Fig. A).
3. Position the door at an angle and pull out the panel upwards by the door handle. (Fig. B).

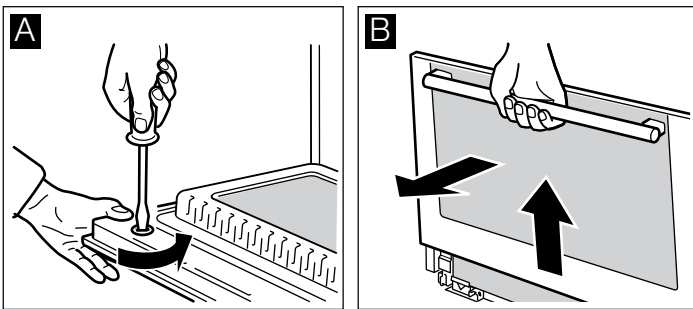

4. Close the door.

### Notes

- Clean the glass panel with glass cleaner and a soft cloth.
- Do not use any sharp or abrasive agents. The glass scraper is not suitable.

### Refitting

1. Insert the door panel into the guide with both hands. (Fig. A).
2. Push the door panel downwards, lift it slightly and hook it in at the top. (Fig. B).

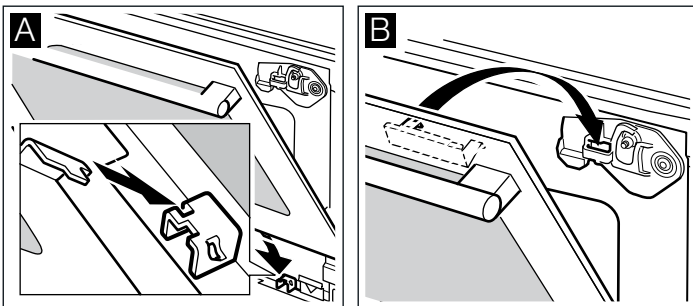

Make sure that the door panel is sitting flush with the control panel.

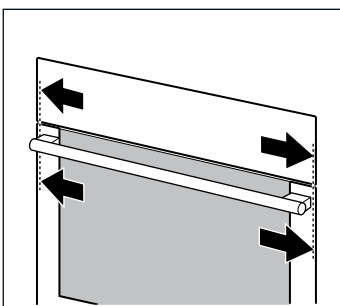

3. Fully open the door, while holding the panels firmly with one hand. (Fig. C).
4. Push the door downwards again and tighten the screws hand-tight using a flat-bladed screwdriver (blade width 8-11 mm), close the door. (Fig. D).

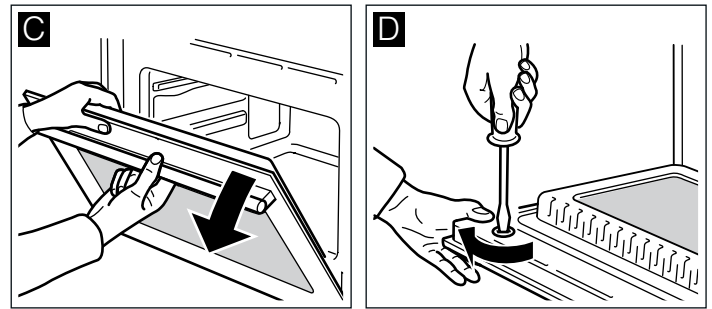

### Caution!

You must not use the oven again until the panels have been properly refitted.

## Cleaning the glass cover

The glass cover can be removed from the oven ceiling for cleaning.

### ⚠ Risk of burns!

Do not remove the panels immediately after switching the appliance off. The oven must be cold.

### Removal

1. Place a tea towel in the oven.
2. Pull the clip on the oven ceiling forwards. (Fig. A)  
Press the front of the glass cover down using the thumb of your other hand. Let go of the clip.
3. Slide the cover forwards using both hands and rest it on the grill element. (Fig. B)

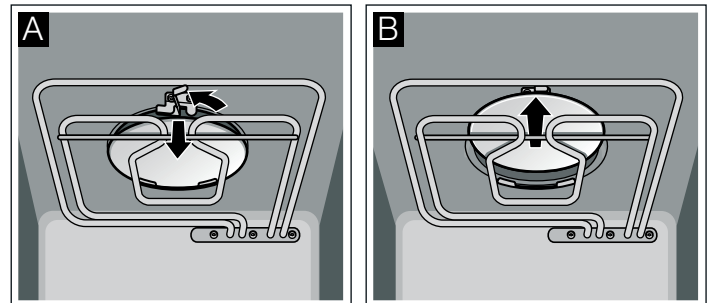

4. Slide it slightly backwards again. (Fig. C)
5. Tilt down at the side and remove. (Fig. D)

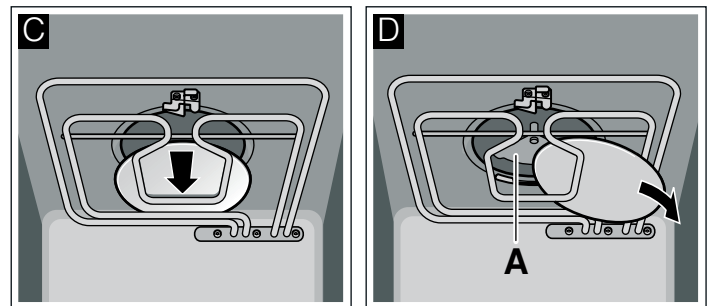

### ⚠ Risk of injury!

Never touch or clean the microwave antenna (A)!

For light soiling:  
Wash the glass cover using hot soapy water.

For heavy soiling:  
Clean the glass cover in the same way as the enamel surfaces in the oven.

### Refitting

1. Slide in the cover with the smooth side facing downwards and rest it on the grill element. (Fig. A)
2. Use both hands to slide it back into the two catches. (Fig. B).

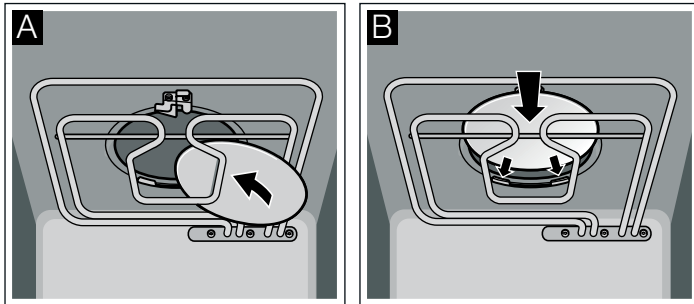

3. Pull the clip forwards and push the glass cover upwards. Let go of the clip. (Fig. C)

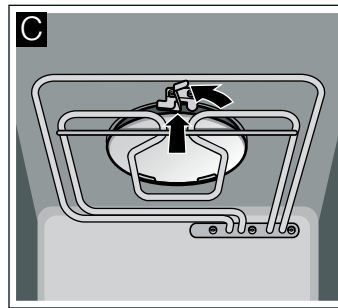

Remove the tea towel from the oven.

### **⚠ Risk of serious damage to health.!**

Never operate the appliance without the microwave glass cover. Microwave energy may escape.

## Malfunction table

Malfunctions often have simple explanations. Please refer to the malfunction table before calling the after-sales service.

If a meal does not turn out exactly as you wanted, refer to the *Tested for you in our cooking studio* section, where you will find plenty of cooking tips and tricks.

### **⚠ Risk of electric shock!**

Incorrect repairs are dangerous. Repairs may only be carried out by one of our trained after-sales engineers.

### Malfunction table

Problem	Possible cause	Remedy/information
The appliance does not work	Faulty circuit breaker	Look in the fuse box to make sure that the fuse for the appliance is OK.
	Plug not plugged in	Plug in the plug.
	Power cut	Check whether the kitchen light works.
⌚ and four zeros light up in the display.	Power cut	Reset the clock.
The oven does not heat up. The colon in the display is flashing.	The oven is in demonstration mode.	Switch off the circuit breaker in the fuse box and switch it on again after approx. 20 seconds. Then, within approx. 2 minutes, press and hold the ⏸ button for approx. 4 seconds until the colon lights up continuously.
F8 appears in the display.	The automatic switch-off has been activated.	Turn the function selector to the off position.
The microwave does not switch on.	Door not fully closed.	Check whether food residues or foreign objects is trapped in the door. Make sure that the sealing surfaces are clean. Check whether the door seal is twisted.
	The microwave was not started.	Press the ▶ button.
The appliance does not heat up to the temperature which has been set.	The ▶ button was not pressed.	Press the ▶ button.
Microwave operation has been cancelled for no apparent reason.	The microwave has a fault.	If this fault occurs repeatedly, please call the after-sales service. Oven operation without microwave is possible.
With microwave operation, the food takes longer to heat up than before.	The microwave power setting is too low.	Select a higher power setting.
	A larger amount than usual has been placed in the appliance.	Double the amount = almost double the time
	The food was colder than usual.	Stir or turn the food during cooking

### Error messages

If an error message with **E** appears, press the ⌚ button. Then reset the clock. If the error message appears again, call the after-sales service.

You can take remedial action yourself for some error messages.

Error message	Possible cause	Remedy/Note
The error message "E101" or "E104" appears on the clock display.	The temperature sensor has failed.	Call the after-sales service. Microwave operation is possible on its own.
The error message "E010", "E310", "E009" or "E309" appears on the clock display.	Technical malfunction.	Call the after-sales service.

## Replacing the oven light bulb

It is possible to replace the oven light. Heat-resistant 12 V, 20 W halogen bulbs can be obtained from After-sales Service or a specialist retailer.

### **⚠ Risk of electric shock!**

Never replace the oven light when the appliance is switched on. Pull out the mains plug or switch off the appliance at the circuit breaker in the fuse box.

**Note.** Always remove the new halogen bulb from the packaging using a dry cloth. This increases the service life of the bulb.

### Method

1. Switch off the circuit breaker in the fuse box.
2. Place a tea towel in the cold oven to prevent damage.
3. Remove the glass cover. To do so, prise open the glass cover at the bottom by hand. Should you experience difficulties removing the glass cover, use a spoon to help. (Fig. A)
4. Remove the bulb and replace with a bulb of the same type. (Fig. B)

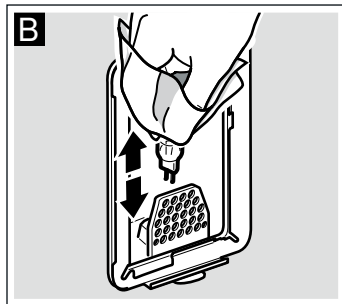
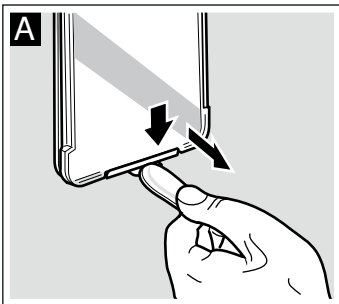

5. Refit the glass cover. (Fig. C)

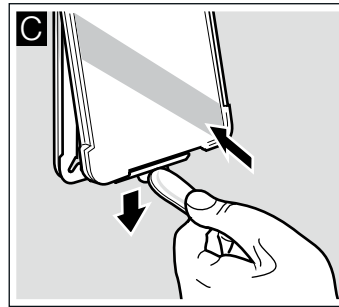

6. Remove the tea towel. Switch the circuit breaker in the fuse box back on or plug in the mains plug.

## Replacing the door seal

If the door seal is defective, it must be replaced. Replacement seals for your appliance can be obtained from the after-sales service. Please supply your appliance's E number and FD number.

### **⚠ Risk of serious damage to health.!**

Never use the appliance if the door seal is damaged. Microwave energy may escape. Do not use the appliance again until it has been repaired.

1. Open the oven door.
2. Remove the old door seal.
3. There are 5 hooks attached to the door seal. Use these hooks to attach the new seal to the oven door.

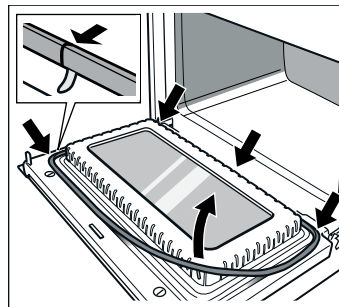

**Note.** The presence of the join at the bottom of the door seal in the centre is technically required.

## After-sales service

Our after-sales service is there for you if your appliance needs to be repaired. We will always find the right solution in order to avoid unnecessary visits from a service technician.

### E number and FD number

When calling us, please give the product number (E no.) and the production number (FD no.) so that we can provide you with the correct advice. The rating plate bearing these numbers can be found in the oven. You can make a note of the number of your appliance and the telephone number of the after-sales service in the space below to save time should it be required.

E no.

FD no.

After-sales service ☎

Please note that there will be a fee for a visit by a service technician in the event of a malfunction, even during the warranty period.

Please find the contact data of all countries in the enclosed customer service list.

### To book an engineer visit and product advice

- GB** 0844 8928979  
Calls from a BT landline will be charged at up to 3 pence per minute. A call set-up fee of up to 6 pence may apply.
- IE** 01450 2655

Trust the expertise of the manufacturer, and rest assured that the repair will be carried out by trained service technicians using original spare parts for your domestic appliance.

This appliance corresponds to the standards EN 55011 and CISPR 11. It is a Group 2, Class B product.

Group 2 means that microwaves are produced for the purpose of heating food. Class B states that the appliance is suitable for private households.

## Energy and environment tips

Here you can find tips on how to save energy when baking and roasting and how to dispose of your appliance properly.

### Saving energy

Only preheat the oven if this is specified in the recipe or in the operating instruction tables.

Use dark, black lacquered or enamelled baking tins. They absorb the heat particularly well.

Open the appliance door as little as possible during cooking, baking or roasting.

It is best to bake several cakes one after the other. The cooking compartment is still warm. This may reduce the baking time for the second cake.

For longer cooking times, you can switch the oven off 10 minutes before the end of the cooking time and use the residual heat to finish cooking.

### Environmentally-friendly disposal

Dispose of packaging in an environmentally-friendly manner.



This appliance complies with European Directive 2002/96/EC on Waste Electrical and Electronic Equipment (WEEE). The directive gives a framework for the collection and recycling of old appliances, which is valid across the EU.

## Automatic programmes

The automatic programmes enable you to prepare food very easily. You select the programme and enter the weight of your food. The automatic programme makes the optimum setting. You can select from 20 programmes.

### Making settings

When you have selected a programme, set the oven. The temperature selector must be in the off position.

Example in diagram: Yeast cake (programme 2) with a weight of 1 kilogramme.

1. Set the function selector to automatic programmes .  
The first programme number appears in the display.

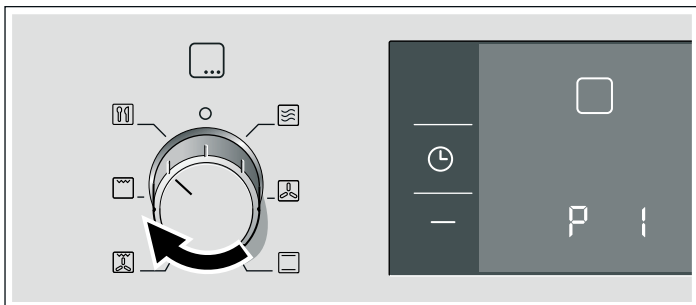

2. Use the **+or-** button to select the programme number.

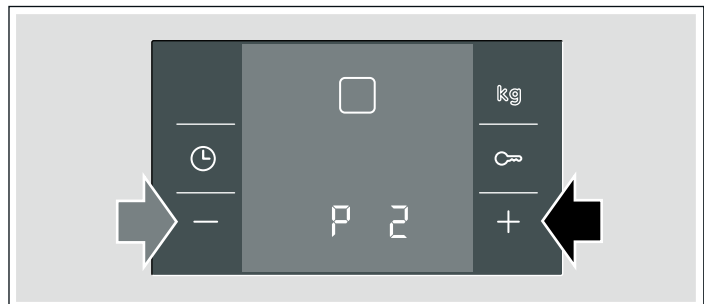

3. Press the **kg** button. The display shows 0.50 kilogrammes as the suggested weight.





4. Use the + or – button to set the weight.



5. Press the ▶ button. The programme starts.

The cooking time starts counting down and the ⏸ symbol is in brackets.

#### Programme has ended

A signal sounds. The oven stops heating. 00:00 is shown in the display. Turn the function selector to the zero position. The oven switches off. You can stop the audible signal by pressing the ⏸ button.

#### Changing the programme

Once you have started the programme, the programme number and weight cannot be changed.

#### Cancelling the programme

Press and hold the ▶ button for approximately 4 seconds and turn the function selector to the zero position. The oven switches off.

#### Changing the cooking time and end time

If using automatic programmes, you cannot change the cooking time or end time.

### Defrosting and cooking with the automatic programmes

#### Notes

- Take the food out of its packaging and weigh it. If it is not possible to enter the exact weight, you should round it up or down.

- Always use microwaveable ovenware, e.g. made of glass, ceramic or the universal pan. Observe the accessories tips in the programme table.
- Place the food in the cold cooking compartment.
- A table of suitable types of food with appropriate weight ranges and the accessories required can be found in the section after the tips.
- It is not possible to set a weight outside the weight range.
- With many dishes, a signal sounds after a certain time. Turn or stir the food.

#### Defrost

#### Notes

- If possible, freeze and store food flat and in portions at -18 °C.
- Put the frozen food on shallow tableware, e.g. a glass or porcelain plate.
- Cover thin and protruding parts with small pieces of aluminium foil. This prevents these parts from cooking prematurely. Ensure that the aluminium foil does not touch the walls of the cooking compartment.
- After defrosting, allow the food to defrost for a further 10 to 90 minutes so that it acquires an even temperature.
- Liquid will be produced when defrosting meat, poultry or fish. Drain off this liquid when you turn the food. Under no circumstances should it be used for other purposes or be allowed to come into contact with other foods.
- Place beef, lamb and pork on the ovenware fatty-side down first.
- Bread should only be defrosted in the required amounts, as it quickly becomes stale.
- After turning, remove any minced meat that has already defrosted.
- Whole poultry should be placed in the ovenware breast-side down and poultry portions skin-side down. Cover legs and wings with small pieces of aluminium foil.
- For whole fish, cover the tail with aluminium foil, for fish fillets cover the edges and for fish steaks cover the protruding ends.

Programme no.	Suitable food	Weight range in kg	Ovenware/accessories, shelf height
<b>Defrost</b>			
1	Loaf of bread***	Wheat bread, mixed wheat bread, wholemeal bread	0.20 - 1.50 Shallow ovenware without a lid Wire rack, level 1
2	Cakes, dry*	Sponge cake without glaze or icing, plaited yeast cake	0.20 - 1.50 Shallow ovenware without a lid Wire rack, level 1
3	Minced meat*	Minced beef, lamb, or pork	0.20 - 1.00 Shallow ovenware without a lid Wire rack, level 1
4	Whole poultry**	Chicken, duck	0.70 - 2.00 Shallow ovenware without a lid Wire rack, level 1
5	Whole fish**	Trout, haddock, cod	0.20 - 1.20 Shallow ovenware without a lid Wire rack, level 1

\* Signal to turn after the cooking time is approximately halfway through

\*\* Signal to turn after 1/3 and 2/3 of the cooking time has elapsed

\*\*\* Signal to turn after 2/3 of the cooking time has elapsed

#### Cooking Vegetables

#### Notes

- Fresh vegetables:  
Cut into equal sized pieces. Add 2 tablespoons of water for every 100 g of vegetables.

- Frozen vegetables:  
This programme is only suitable for blanched, not pre-cooked vegetables. It is not suitable for frozen vegetables in cream sauce. Add 1 to 2 tablespoons of water per 100 g. Do not add water to spinach or red cabbage.
- After the programme has ended, leave the vegetables to stand for approx. a further 5 minutes.

### Potatoes

#### Notes

- Boiled potatoes:  
Cut into pieces of equal size. Add 2 tablespoons of water per 100 g of potatoes, and salt to taste.

- After the programme has ended, leave the potatoes to stand for approx. a further 5 minutes. Strain away the remaining water beforehand.

### Rice

#### Notes

- Do not use boil-in-the-bag rice. Rice foams a lot during cooking. Enter the uncooked weight (without liquid). Add two to two and a half times the amount of liquid to the rice.
- After the programme has ended, leave the cereal to stand for approx. a further 5 to 10 minutes.

### Fish

**Note.** Fish fillet, fresh

Add 1 to 3 tablespoons of water or lemon juice.

Programme no.		Suitable food	Weight range in kg	Ovenware/accessories, shelf height
<b>Cooking</b>				
6	Fresh vegetables*	Cauliflower, broccoli, carrots, kohlrabi, leeks, peppers, courgettes	0.20 - 1.00	Ovenware with lid, wire rack, Level 1
7	Frozen vegetables*	Cauliflower, broccoli, carrots, kohlrabi, red cabbage, spinach	0.20 - 1.00	Ovenware with lid, wire rack, Level 1
8	Boiled potatoes*	Waxy potatoes, mainly waxy potatoes or floury potatoes	0.20 - 1.00	Ovenware with lid, wire rack, Level 1
9	Rice, long grain rice*		0.10 - 0.50	Deep ovenware with lid Wire rack, level 1
10	Steam fresh fish fillet	Fillet of pike, cod, rosefish, pollock, pike-perch	0.20 - 1.00	Ovenware with lid, wire rack, Level 1

\* Signal to stir halfway through the cooking time.

### Combi cooking

#### Pizza

**Note.** Use prebaked, frozen pizza.

#### Poultry

#### Notes

- Place the chicken in the ovenware breast-side down.
- Place chicken portions in the ovenware skin-side up.
- Cook turkey breast without the skin. Add 100 to 150 ml of liquid to the turkey breast. Add another 50 to 100 ml of liquid after turning if necessary.

- After the programme has ended, leave the turkey breast to stand for a further 10 minutes.

### Meat

#### Notes

- Cook sirloin fatty-side down first.
- Joint of beef, joint of veal, leg of lamb and joint of pork:  
The joint should cover two thirds of the ovenware base. Add 50 ml of liquid to the joint. Add another 50-100 ml of liquid after turning, if necessary.
- Add 50 to 100 ml of liquid to the meat loaf.
- After the programme has ended, leave the roast to stand for another 10 minutes.

Programme no.		Suitable food	Weight range in kg	Ovenware/accessories, shelf height
<b>Combi-cooking</b>				
11	Pizza, frozen	Pizza with thin base, prebaked	0.30 - 0.50	Universal pan Level 1
12	Lasagne bolognese, frozen		0.40 - 1.00	Ovenware without lid, wire rack, Level 1
13	Chicken, fresh***	Whole chicken	0.80 - 1.80	Deep ovenware with lid Wire rack, level 1
14	Chicken portions, fresh	Chicken thigh, half chicken	0.40 - 1.20	Deep ovenware with lid Wire rack, level 1
15	Turkey breast, fresh*	Skinless turkey breast	0.80 - 2.00	Ovenware with lid, wire rack, Level 1
16	Pot-roasted beef, fresh**		0.80 - 2.00	Ovenware with lid, wire rack, Level 1
17	Sirloin, fresh*	Thick piece of sirloin, 5-6 cm	0.80 - 2.00	Ovenware without lid, wire rack, Level 1

\* Signal to turn after the cooking time is approximately halfway through

\*\* Signal to turn after  $\frac{1}{3}$  and  $\frac{2}{3}$  of the cooking time has elapsed

\*\*\* Signal to turn after  $\frac{2}{3}$  of the cooking time has elapsed

Programme no.	Suitable food	Weight range in kg	Ovenware/accessories, shelf height
18	Joint of pork, fresh***	Boned neck joint, rolled roasting joint	0.80 - 2.00 Ovenware with lid, wire rack, Level 1
19	Leg of lamb, fresh*	Leg of lamb, boned	0.80 - 2.00 Ovenware with lid, wire rack, Level 1
20	Meat loaf	approx. 8 cm deep	0.80 - 1.50 Ovenware with lid, wire rack, Level 1

\* Signal to turn after the cooking time is approximately halfway through

\*\* Signal to turn after  $\frac{1}{3}$  and  $\frac{2}{3}$  of the cooking time has elapsed

\*\*\* Signal to turn after  $\frac{2}{3}$  of the cooking time has elapsed

## Tested for you in our cooking studio

Here you will find a selection of recipes and the ideal settings for them. We will show you which type of heating and which temperature or microwave power setting is best for your meal. You can find information about suitable accessories and the height at which they should be inserted. There are also tips about ovenware and preparation methods.

### Notes

- The values in the table always apply to food placed into the cooking compartment when it is cold and empty. Only preheat the appliance if the table specifies that you should do

so. Before using the appliance, remove all accessories from the cooking compartment that you will not be using.

- Do not line the accessories with greaseproof paper until after they have been preheated.
- The times specified in the tables are only guidelines. They will depend on the quality and composition of the food.
- Use the accessories supplied. Additional accessories may be obtained from specialist retailers or from the after-sales service.
- Always use an oven cloth or oven gloves when taking accessories or ovenware out of the cooking compartment.

## Defrosting, heating up and cooking with the microwave

The following tables provide you with numerous options and settings for the microwave.

The times specified in the tables are only guidelines. They may vary according to the ovenware used, the quality, temperature and consistency of the food.

Time ranges are often specified in the tables. Set the shortest time first and then extend the time if necessary.

It may be that you have different quantities from those specified in the tables. A rule of thumb can be applied:

Double the amount - almost twice the cooking time,  
Half the amount - half the cooking time.

Insert the wire rack at level 1. Place the ovenware in the centre. The food will then absorb the microwaves from all sides.

### Defrosting

#### Notes

- Place the frozen food in an open container on the wire rack.
- Delicate parts such as the legs and wings of chicken or fatty outer layers of roasts can be covered with small pieces of aluminium foil. The foil must not touch the cooking compartment walls. You can remove the foil half way through the defrosting time.
- Turn or stir the food once or twice during the defrosting time. Large pieces of food should be turned several times. When turning, remove any liquid that has resulted from defrosting.
- Leave defrosted items to stand at room temperature for a further 10 to 60 minutes so that the temperature can stabilise. The giblets can be removed from poultry at this point.

Defrost	Weight	Microwave power setting in watts, cooking time in minutes	Notes
Whole pieces of beef, veal or pork (on the bone or boned)	800 g	180 W, 15 mins + 90 W, 10 - 15 mins	Turn several times
	1 kg	180 W, 15 mins + 90 W, 20-30 mins	
	1.5 kg	180 W, 25 mins + 90 W, 25-30 mins	
Meat in pieces or slices of beef, veal or pork	200 g	180 W, 5 mins + 90 W, 4-6 mins	Separate any defrosted parts when turning
	500 g	180 W, 8 mins + 90 W, 5-10 mins	
	800 g	180 W, 10 mins + 90 W, 10-15 mins	
Minced meat, mixed	200 g	90 W, 10-15 mins	Turn several times, remove any defrosted meat
	500 g	180 W, 5 mins + 90 W, 10-15 mins	
	800 g	180 W, 10 mins + 90 W, 15-20 mins	
	1 kg	180 W, 13 mins + 90 W, 20-25 mins	
Poultry or poultry portions	600 g	180 W, 5 mins + 90 W, 13-18 mins	Turn during cooking.
	1.2 kg	180 W, 10 mins + 90 W, 20-25 mins	
Duck	2 kg	180 W, 20 mins + 90 W, 30-40 mins	Turn several times

<b>Defrost</b>	<b>Weight</b>	<b>Microwave power setting in watts, cooking time in minutes</b>	<b>Notes</b>
Goose	4.5 kg	180 W, 30 mins + 90 W, 60-80 mins	Turn every 20 minutes, remove liquid that escapes during defrosting
Fish fillet, fish steak or slices	400 g	180 W, 5 mins + 90 W, 10-15 mins	Separate any defrosted parts.
Whole fish	300 g	180 W, 3 mins + 90 W, 10-15 mins	Turn during cooking.
	600 g	180 W, 8 mins + 90 W, 10-15 mins	
Vegetables, e.g. peas	300 g	180 W, 8-13 mins	Stir carefully during defrosting.
	600 g	180 W, 10 mins + 90 W, 8-13 mins	
Fruit, e.g. raspberries	300 g	180 W, 7-10 mins	Stir carefully during defrosting and separate any defrosted parts.
	500 g	180 W, 8 mins + 90 W, 5-10 mins	
Butter, defrosting	125 g	90 W, 7-9 mins	Remove all packaging.
	250 g	180 W, 2 mins + 90 W, 3-5 mins	
Loaf of bread	500 g	180 W, 3 mins + 90 W, 10-15 mins	Turn during cooking.
	1 kg	180 W, 3 mins + 90 W, 15-25 mins	
Cakes, dry, e.g. sponge cake	500 g	90 W, 10-15 mins	Only for cakes without icing, cream or crème pâtissière, separate the pieces of cake.
	750 g	180 W, 2 mins + 90 W, 10-15 mins	
Cakes, moist, e.g. fruit flan, cheesecake	500 g	180 W, 5 mins + 90 W, 15-20 mins	Only for cakes without icing, cream or crème pâtissière
	750 g	180 W, 10 mins + 90 W, 15-20 mins	

### Defrosting, heating up or cooking frozen food

#### Notes

- Take ready meals out of the packaging. They will heat up more quickly and evenly in microwaveable ovenware. The different components of the meal may not require the same amount of time to heat up .
- Food which lies flat will cook more quickly than food which is piled high. You should therefore distribute the food so that it is as flat as possible in the ovenware. Different foodstuffs should not be placed in layers on top of one another.

- Always cover the food. If you do not have a suitable cover for your ovenware, use a plate or special microwave foil.
- Stir or turn the food 2 or 3 times during cooking.
- After heating, allow the food to stand for a further 2 to 5 minutes so that it can achieve an even temperature.
- Always use an oven cloth or oven gloves when removing plates from the oven.
- This will help the food retain its own distinct taste, so it will require less seasoning.

<b>Defrosting, heating up or cooking frozen food</b>	<b>Weight</b>	<b>Microwave power setting in watts, cooking time in minutes</b>	<b>Notes</b>
Menu, plated meal, ready meal	300-400 g	600 W, 11-15 mins	Take meal out of packaging; cover food before heating
Soup	400-500 g	600 W, 8-13 mins	Ovenware with lid
Stew	500 g	600 W, 10-15 mins	Ovenware with lid
	1 kg	600 W, 20-25 mins	
Slices or pieces of meat in sauce, e.g. goulash	500 g	600 W, 12-17 mins	Ovenware with lid
	1 kg	600 W, 25-30 mins	
Fish, e.g. fillets	400 g	600 W, 10-15 mins	Covered
	800 g	600 W, 18-23 mins	
Side dishes, e.g. rice, pasta	250 g	600 W, 2-5 mins	Ovenware with lid; add liquid
	500 g	600 W, 7-10 mins	
Vegetables, e.g. peas, broccoli, carrots	300 g	600 W, 8-12 mins	Ovenware with lid; add 1 tbsp of water
	600 g	600 W, 13-18 mins	
Creamed spinach	450 g	600 W, 11-16 mins	Cook without additional water

### Heating food

#### Risk of scalding!

There is a possibility of delayed boiling when a liquid is heated. This means that the liquid reaches boiling temperature without the usual steam bubbles rising to the surface. Even if the container only moves a little, the hot liquid can suddenly boil over and spatter. When heating liquids, always place a spoon in the container. This will prevent delayed boiling.

#### Caution!

Metal - e.g. a spoon in a glass - must be kept at least 2 cm from the oven walls and the inside of the door. Sparks could irreparably damage the glass on the inside of the door.

#### Notes

- Take ready meals out of the packaging. They will heat up more quickly and evenly in microwaveable ovenware. The different components of the meal may not require the same amount of time to heat up .

- Always cover the food. If you do not have a suitable cover for your container, use a plate or special microwave foil.
- Stir or turn the food several times during the heating time. Check the temperature.
- After heating, allow the food to stand for a further 2 to 5 minutes so that it can achieve an even temperature.
- Always use an oven cloth or oven gloves when removing plates from the oven.

Heating food	Weight	Microwave power setting in watts, cooking time in minutes	Notes
Menu, plated meal, ready meal	350-500 g	600 W, 4-8 mins	Take meal out of packaging; cover food before heating
Drinks	150 ml	900 W, 1-3 mins	Place a spoon in the glass; do not overheat alcoholic drinks; check occasionally while heating
	300 ml	900 W, 3-4 mins	
	500 ml	900 W, 4-5 mins	
Baby food, e.g. baby bottle	50 ml	360 W, ½-1 min	Place baby bottle on the cooking compartment floor without the teat or lid; shake or stir well after heating; always be sure to check the temperature
	100 ml	360 W, 1-1½ mins	
	200 ml	360 W, 1-2 mins	
Soup 1 cup	175 g	900 W, 1½-2 mins	-
Soup, 2 cups	175 g each	900 W, 2-4 mins	
Soup, 4 cups	175 g each	900 W, 4-6 mins	
Slices or pieces of meat in sauce, e.g. goulash	500 g	600 W, 7-10 mins	Covered
Stew	400 g	600 W, 5-7 mins	Ovenware with lid
	800 g	600 W, 7-10 mins	
Vegetables	150 g	600 W, 2-3 mins	Add a little liquid
	300 g	600 W, 3-5 mins	

### Cooking food

#### Notes

- Food which lies flat will cook more quickly than food which is piled high. You should therefore distribute the food so that it is as flat as possible in the ovenware. Different foodstuffs should not be placed in layers on top of one another.
- Cook the food in ovenware with a lid. If you do not have a suitable lid for your ovenware, use a plate or special microwave foil.
- This will help the food retain its own distinct taste, so it will require less seasoning.
- After cooking, allow the food to stand for a further 2 to 5 minutes so that it can achieve an even temperature.
- Always use an oven cloth or oven gloves when removing plates from the oven.

Cooking food	Weight	Microwave power setting in watts, cooking time in minutes	Notes
Whole chicken, fresh, no giblets	1.5 kg	600 W, 25-30 mins	Turn halfway through the cooking time
Fish fillet, fresh	400 g	600 W, 8-13 mins	-
Fresh vegetables	250 g	600 W, 6-10 mins	Cut into equal-sized pieces; add 1 to 2 tbsp water per 100 g; stir during cooking
	500 g	600 W, 10-15 mins	
Potatoes	250 g	600 W, 8-11 mins	Cut into equal-sized pieces; add 1 to 2 tbsp water per 100 g; stir during cooking
	500 g	600 W, 12-15 mins	
	750 g	600 W, 15-22 mins	
Rice	125 g	600 W, 4-6 mins + 180 W, 12-15 mins	Add double the quantity of liquid and use deep ovenware with a lid
	250 g	600 W, 7-9 mins + 180 W, 15-20 mins	
Sweet foods, e.g. blancmange (instant)	500 ml	600 W, 5-8 mins	Stir 2 to 3 times with an egg whisk while heating
Fruit, compote	500 g	600 W, 9-12 mins	-

### Popcorn for the microwave

#### Notes

- Use heat-resistant, flat glass ovenware, e.g. the lid of an ovenproof dish, a glass plate or a glass tray (Pyrex)
- Always place the ovenware on the wire rack at level 1.
- Do not use porcelain or extremely curved plates.
- Make the settings as described in the table. You can adjust the timings according to product and amount.
- So that the popcorn doesn't burn, briefly take the popcorn bag out of the oven after 1 minute and 30 seconds and shake it. Take care as the bag will be hot!

## Risk of scalding!

- Open the popcorn bag carefully as hot steam may be released.

- Never set the microwave to full power.

	Weight	Accessories	Level	Microwave power in watts, Cooking time in minutes
Popcorn for the microwave	1 bag, 100 g	Ovenware, wire rack	1	600 W, 4 mins

## Microwave tips

You cannot find any information about the settings for the quantity of food you have prepared.	Increase or reduce the cooking times using the following rule of thumb: Double the amount = almost double the cooking time Half the amount = half the cooking time
The food has become too dry.	Next time, set a shorter cooking time or select a lower microwave power setting. Cover the food and add more liquid.
When the time has elapsed, the food is not defrosted, hot or cooked.	Set a longer time. Large quantities and food which is piled high require longer times.
When the time has elapsed, the food is overheated at the edge but not done in the middle.	Stir it during the cooking time and next time, select a lower microwave power setting and a longer cooking time.
After defrosting, the poultry or meat is defrosted on the outside but not defrosted in the middle.	Next time, select a lower microwave power setting. If you are defrosting a large quantity, turn it several times.

## Cakes and pastries

### About the tables

#### Notes













- The times given apply to food placed in a cold oven.
- The temperature and baking time depend on the consistency and amount of the mixture. This is why temperature ranges are given in the tables. Begin with the lower temperature and,

if necessary, use a higher setting the next time, since a lower temperature results in more even browning.

- Additional information can be found in the *Baking tips* section following the tables.
- Always place the cake tin in the centre of the wire rack.

### Baking tins

**Note.** It is best to use dark-coloured metal baking tins.

Cakes in tins	Accessories	Level	Type of heating	Temperature °C	Microwave power in watts	Cooking time in minutes
Sponge cake, simple	Ring tin/round tin	1		160-180	90 W	30-40
Sponge cake, delicate (e.g. sand cake)	Ring tin/round tin	1		150-170	-	60-80
Sponge flan base	Flan tin	2		160-180	-	25-35
Delicate fruit flan, sponge	Springform/ring tin	1		160-180	90 W	30-40
Sponge base, 2 eggs	Flan tin	1		150-160	-	20-25
Sponge flan, 6 eggs (preheat)	Dark springform cake tin	1		170-180	-	30-40
Shortcrust pastry base with crust	Dark Springform cake tin**	1		170-190	-	30-40
Fruit tart/cheesecake with pastry base*	Dark springform cake tin	2		160-170	180 W	30-40
Swiss flan	Dark springform cake tin	1		190-200	-	40-50
Ring cake	Ring cake tin	1		160-180	90 W	30-40
Nut cake	Dark springform cake tin	1		170-180	90 W	35-45
Pizza, thin base, light topping, preheat	Round pizza tray	1		220-240	-	15-20
Savoury cakes	Dark Springform cake tin**	1		180-190	-	50-60

\* Allow cake to cool in the oven for approx. 20 minutes.

\*\* Place on the universal pan

Cakes on the universal pan	Accessories	Level	Type of heating	Temperature °C	Microwave power in watts	Cooking time in minutes
Sponge with dry topping	Universal pan	2	☐	160-180	-	25-35
Sponge with moist topping (fruit)	Universal pan	1	☒	160-180	90 W	30-40
Yeast dough with dry topping	Universal pan	2	☐	170-190	-	35-45
Yeast dough with moist topping (fruit)	Universal pan	2	☐	170-190	-	45-55
Shortcrust pastry with dry topping	Universal pan	2	☐	160-180	-	25-35
Shortcrust pastry with moist topping (fruit)	Universal pan	1	☐	160-180	-	50-60
Swiss flan	Universal pan	1	☐	190-200	-	40-50
Swiss roll (preheat)	Universal pan	2	☐	170-190	-	10-20
Plaited loaf with 500 g flour	Universal pan	2	☐	160-180	-	40-50
Stollen with 500 g flour	Universal pan	2	☐	150-170	-	60-70
Stollen with 1 kg flour	Universal pan	2	☒	140-150	-	65-75
Strudel, sweet	Universal pan	1	☒	190-210	180 W	30-40
Pizza	Universal pan	1	☐	210-230	-	25-35
Tarte flambée, preheat	Universal pan	2	☐	240-250	-	15-20

Small baked items	Accessories	Level	Type of heating	Temperature °C	Cooking time in minutes
Biscuits	Universal pan	2	☐	150-170	20-30
Macaroons	Universal pan	2	☐	120-140	35-45
Meringue	Universal pan	2	☐	80-100	90-110
Muffins	Muffin tray on wire rack	2	☐	160-180	35-45
Choux pastry	Universal pan	2	☐	200-220	30-40
Puff pastry	Universal pan	2	☐	170-190	25-25
Leavened cake	Universal pan	2	☐	200-220	20-30

Bread and rolls	Accessories	Level	Type of heating	Temperature °C	Cooking time in minutes
Sourdough bread with 1.2 kg of flour*	Universal pan	2	☐	250 + 170	10 40-50
Flatbread*	Universal pan	2	☒	220-240	15-20
Bread rolls*	Universal pan	2	☐	200-220	20-30
Rolls made with sweet yeast dough*	Universal pan	2	☐	190-210	15-25

\* Preheat the cooking compartment.

## Baking tips

You want to bake according to your own recipe.	Use similar items in the baking tables as a guide.
Use baking tins made of silicone, glass, plastic or ceramic materials.	The baking tin must be heat-resistant up to 250 °C. Cakes in these baking tins will be less brown. When using the microwave, the cooking time will be shorter than the time shown in the table.
How to establish whether sponge cake is baked through.	Approximately 10 minutes before the end of the baking time specified in the recipe, poke the cake with a cocktail stick at its highest point. If the cocktail stick comes out clean, the cake is ready.
The cake collapses.	Use less liquid next time or set the oven temperature 10 degrees lower and extend the baking time. Observe the specified mixing times in the recipe.
The cake has risen in the middle but is lower around the edge.	Only grease the base of the springform cake tin. After baking, loosen the cake carefully with a knife.
The cake is too dark.	Select a lower temperature and bake the cake for a little longer.
The cake is too dry.	When it is done, make small holes in the cake using a toothpick. Then drizzle fruit juice or an alcoholic beverage over it. Next time, select a temperature 10 degrees higher and reduce the baking time.

The bread or cake (e.g. cheesecake) looks good, but is soggy on the inside (sticky, streaked with water).	Use slightly less fluid next time and bake for slightly longer at a lower temperature. When baking cakes with a moist topping, bake the base first, cover with almonds or bread crumbs and then add the topping. Please follow the recipe and follow the baking times.
The cake cannot be turned out of the dish when it is turned upside down.	After baking, allow the cake to cool for a further 5 to 10 minutes, then it will be easier to turn out of the tin. If it still sticks, carefully loosen the cake around the edges using a knife. Turn the cake tin upside down again and cover it several times with a cold, wet cloth. Next time, grease the tin well and sprinkle some bread crumbs into it.
You have measured the temperature of the oven using your own meat thermometer and found there is a discrepancy.	The oven temperature is measured by the manufacturer after a specified period of time using a test rack in the centre of the cooking compartment. Ovenware and accessories affect the temperature measurement, so there will always be some discrepancy when you measure the temperature yourself.
Sparks are generated between the tin and the wire rack.	Check that the tin is clean on the outside. Change the position of the tin in the cooking compartment. If this does not help, continue baking but without the microwave. The baking time will then be longer.

## Roasting and grilling

### About the tables

The temperature and roasting time depend on the type and amount of food being cooked. This is why temperature ranges are given in the tables. Begin with the lower temperature and, if necessary, use a higher setting the next time,

For more information, see the section entitled *Tips for grilling and roasting* which follows the tables.

### Ovenware

You may use any heat-resistant ovenware which is suitable for use in a microwave. Metal roasting dishes are not suitable for roasting with microwaves.

The ovenware can become very hot. Use oven gloves to take the ovenware out of the oven.

Place hot glass ovenware on a dry kitchen towel after they have been removed from the oven. The glass could crack if placed on a cold or wet surface.

### Tips for roasting

Use a deep roasting dish for roasting meat and poultry.

Check that your ovenware fits in the cooking compartment. It should not be too big.

Meat:

Cover approx. two thirds of the ovenware base with liquid. Add a little more liquid for pot roasts. Turn pieces of meat halfway through the cooking time. When the roast is ready, turn off the oven and allow it to rest for an additional 10 minutes. This allows better distribution of the meat juices.

Poultry:

Turn the pieces of meat after  $\frac{2}{3}$  of the cooking time has elapsed.

### Tips for grilling

Always keep the oven door closed when grilling and do not preheat.

As far as possible, the pieces of food you are grilling should be of equal thickness. Steaks should be at least 2 to 3 cm thick. This will allow them to brown evenly and remain succulent and juicy. Do not add salt to steaks until they have been grilled.

Use tongs to turn the pieces of food you are grilling. If you pierce the meat with a fork, the juices will run out and it will become dry.

Dark meat, e.g. beef, browns more quickly than lighter-coloured meat such as veal or pork. When grilling light-coloured meat or fish, these often only brown slightly on the surface, although they are cooked and juicy on the inside.

The grill element switches off and on again automatically. This is normal. The grill setting determines how frequently this will happen.

### Tips for braising

Use ovenware with a lid for braising fish.

Add two to three tablespoons of liquid and a little lemon juice or vinegar into the ovenware.

### Beef

#### Notes





- Turn pot-roasted beef after  $\frac{1}{3}$  and  $\frac{2}{3}$  of the cooking time. Finally, allow to stand for approx. a further 10 minutes.
- Turn fillet of beef and sirloin halfway through the cooking time. Finally, allow to stand for approx. a further 10 minutes.
- Turn steaks after  $\frac{2}{3}$  of the cooking time.

Beef	Accessories	Level	Type of heating	Temperature in °C, grill setting	Microwave power in watts	Cooking time in minutes
Pot-roasted beef, approx. 1 kg	Ovenware with lid, wire rack	1	☐	190-210	-	120-140
Pot-roasted beef, approx. 1.5 kg	Ovenware with lid, wire rack	1	☐	180-200	-	140-160
Pot-roasted beef, approx. 2 kg	Ovenware with lid, wire rack	1	☐	170-190	-	160-180
Fillet of beef, medium, approx. 1 kg	Ovenware with lid, wire rack	1	☐	200-220	90 W	30-40
Fillet of beef, medium, approx. 1.5 kg	Ovenware with lid, wire rack	1	☐	230-240	90 W	45-55
Sirloin, medium, approx. 1 kg	Ovenware without lid, wire rack	1	☐	240-250	180 W	30-40
Steak, medium, 3 cm thick	Universal pan + Wire rack	1 3	☑	3	-	1st side: approx. 10-15 2nd side: approx. 5-10



## Veal

**Note.** Turn joints and knuckle of veal halfway through the cooking time. Finally, allow to stand for approx. a further 10 minutes.









Veal	Accessories	Level	Type of heating	Temperature in °C	Microwave power in watts	Cooking time in minutes
Joint of veal, approx. 1 kg	Ovenware with lid, wire rack	1		210-220	90 W	60-70
Joint of veal, approx. 1.5 kg	Ovenware with lid, wire rack	1		200-210	90 W	70-80
Joint of veal, approx. 2 kg	Ovenware with lid, wire rack	1		190-200	90 W	80-100
Knuckle of veal, approx. 1.5 kg	Ovenware with lid, wire rack	1		190-200	-	120-130

## Pork

### Notes





■ Turn lean joints of pork and rindless joints halfway through the cooking time. Finally, allow to stand for approx. a further 10 minutes.



- Place the joint in the ovenware rind-side up. Cut into the rind. Do not turn the joint. Finally, allow to stand for approx. a further 10 minutes.
- Do not turn fillet of pork or smoke-cured pork chops. Finally, allow to stand for approx. a further 5 minutes.
- Turn the neck of pork after  $\frac{2}{3}$  of the cooking time.

Pork	Accessories	Level	Type of heating	Temperature in °C, grill setting	Microwave power in watts	Cooking time in minutes
Joint without rind (e.g. neck of pork), approx. 750 g	Ovenware with lid, wire rack	1		220-240	180 W	40-50
Pork roast with rind (e.g. shoulder), approx. 1.5 kg	Ovenware without lid, wire rack	1		180-200	-	150
Pork roast with rind (e.g. shoulder), approx. 2 kg	Ovenware without lid, wire rack	1		170-190	-	180
Fillet of pork, approx. 500 g	Ovenware with lid, wire rack	1		210-230	90 W	20-25
Joint of pork, lean, approx. 1 kg	Ovenware with lid, wire rack	1		210-230	90 W	50-60
Joint of pork, lean, approx. 1.5 kg	Ovenware with lid, wire rack	1		200-220	90 W	70-80
Joint of pork, lean, approx. 2 kg	Ovenware with lid, wire rack	1		190-210	180 W, 10 min. + 90 W, 75-85 min.	85-95
Smoked pork on the bone, approx. 1 kg	Ovenware without lid, wire rack	1	-	-	360 W	45-50
Neck of pork, 2 cm thick	Universal pan + Wire rack	1 3		2	-	1st side: approx. 15-20 2nd side: approx. 10-15

## Lamb and game



**Note.** Turn lamb and game halfway through the cooking time.

Lamb and game	Accessories	Level	Type of heating	Temperature °C, grill setting	Microwave power in watts	Cooking time in minutes
Saddle of lamb on the bone, approx. 1 kg	Ovenware without lid, wire rack	1		190-210	-	40-50
Leg of lamb, boned, medium, approx. 1.5 kg	Ovenware with lid, wire rack	1		180-200	-	90-100
Saddle of venison on the bone, approx. 1 kg	Ovenware with lid, wire rack	1		210-220	-	40-50
Boned leg of roe venison, approx. 1.5 kg	Ovenware with lid, wire rack	1		180-190	-	105-120
Wild boar joint ca. 1.5 kg	Ovenware with lid, wire rack	1		200-220	-	90-100

Lamb and game	Accessories	Level	Type of heating	Temperature °C, grill setting	Microwave power in watts	Cooking time in minutes
Joint of venison, approx. 1.5 kg	Ovenware with lid, wire rack	1		200-220	-	90-100
Rabbit, approx. 1.5 kg	Ovenware with lid, wire rack	1		200-220	90 W	25-35















### Miscellaneous

- Notes**
- Finally, allow the meat loaf to stand for approx. a further 10 minutes.
  - Turn the sausages after  $\frac{2}{3}$  of the cooking time.

Miscellaneous	Accessories	Level	Type of heating	Temperature in °C, grill setting	Microwave power in watts	Cooking time in minutes
Meat loaf, approx. 1 kg of meat	Ovenware without lid, wire rack	1		170-190	600 W, 10 min. + 180 W, 40-50 min.	-
4 to 6 sausages for grilling approx. 150 g each	Universal pan + Wire rack	1 3		3	-	1st side: approx. 10-15 2nd side: approx. 5-10

### Poultry

- Notes**
- Place whole chickens, chicken breasts and small turkeys breast-side down. Turn after  $\frac{2}{3}$  of the cooking time.
  - Place poulard breast-side down. Turn after  $\frac{2}{3}$  of the cooking time and set the microwave power to 180 watts.
  - Place half chickens and chicken portions skin-side up. Do not turn.
  - Turn duck and goose after  $\frac{1}{3}$  and  $\frac{2}{3}$  of the cooking time.
  - Place duck and goose breast skin-side down. Turn halfway through the cooking time.
  - Turn goose legs halfway through the cooking time. Prick the skin.
  - Turn rolled turkey joints after  $\frac{2}{3}$  of the cooking time.
  - Place turkey breast and thighs skin-side down. Turn after  $\frac{2}{3}$  of the cooking time.

Poultry	Accessories	Level	Type of heating	Temperature in °C, grill setting	Microwave power in watts	Cooking time in minutes
Chicken, whole, approx. 1.2 kg	Ovenware with lid, wire rack	1		230-250	360 W	25-35
Poulard, whole	Ovenware with lid, wire rack	1		200-220	360 W 180 W	30 15-25
Chicken halves, 500 g each	Ovenware without lid, wire rack	1		180-200	360 W	30-35
Chicken portions, approx. 800 g	Ovenware without lid, wire rack	1		190-210	360 W	30-35
Chicken portions, approx. 1.5 kg	Ovenware without lid, wire rack	1		190-210	360 W	35-40
Chicken breast approx. 500 g	Ovenware without lid, wire rack	1		190-210	180 W	25-30
Duck, whole, 1.5 - 1.7 kg	Universal pan	1		170-190	180 W	60-80
Duck breast, 2 pieces, 300 to 400 g each	Wire rack + Universal pan*	2 1		3	90 W	18-22
Goose, whole, 3 - 3.5 kg	Universal pan	1		170-190	180 W	80-90
Goose breast, 2 pieces, 500 g each	Wire rack + Universal pan*	2 1		210-230	90 W	20-25
4 goose legs, approx. 1.5 kg	Wire rack + Universal pan*	2 1		170-190	180 W	30-40
Small turkey, whole, approx. 3 kg	Universal pan	1		170-180	180 W	60-70
Rolled turkey joint, approx. 1.5 kg	Ovenware with lid, wire rack	1		190-200	180 W	60-70
Turkey breast, approx. 1kg	Ovenware with lid, wire rack	1		200-210	-	80-90
Turkey thighs, approx. 1.3 kg	Ovenware with lid, wire rack	1		210-230	360 W	45-50

\* Add 50 ml water to the universal pan

## Fish

### Notes

- For grilling, place the whole fish, e.g. trout, onto the middle of the wire rack.

- For braised fish, cook the whole fish in its swimming position.

Fish	Accessories	Level	Type of heating	Grill setting	Microwave power in watts	Cooking time in minutes
Whole fish, e.g. trout approx. 300 g, grilled	Universal pan + Wire rack*	1 3		2	-	1st side: approx. 10-15 2nd side: approx. 8-12
Fish steak, e.g. salmon 3 cm thick, grilled	Universal pan + Wire rack*	1 3		3	-	1st side: approx. 10-12 2nd side: approx. 8-12
2-3 whole fish, 300 g each, grilled	Universal pan + Wire rack*	1 3		2	-	1st side: approx. 10-15 2nd side: approx. 10-15
Whole fish, approx. 1 kg, braised	Ovenware with lid, wire rack	1	-	-	600 W	10-15
Whole fish, approx. 1.5 kg, braised	Ovenware with lid, wire rack	1	-	-	600 W 360 W	10-15 5-10
Whole fish, approx. 2 kg, braised	Ovenware with lid, wire rack	1	-	-	600 W 360 W	15-20 10-15
Fish fillet, e.g. pollock, approx. 800 g, braised	Ovenware with lid, wire rack	1	-	-	600 W	9-14

\* Grease the wire rack first with oil.

## Tips for roasting and grilling

The table does not contain information for the weight of the joint.	For small roasts, select a higher temperature and a shorter cooking time. For larger roasts, select a lower temperature and a longer cooking time.
How to tell when the roast is ready.	Use a meat thermometer (available from specialist shops) or carry out a "spoon test". Press down on the roast with a spoon. If it feels firm, it is ready. If the spoon can be pressed in, it needs to be cooked for a little longer.
The roast looks good but the juices are burnt.	Next time, use a smaller roasting dish or add more liquid.
The roast looks good but the juices are too clear and watery.	Next time, use a larger roasting dish and add less liquid.
The roast is not well-done enough.	Carve the roast. Prepare the gravy in the roasting dish and place the slices of roast meat in the gravy. Finish cooking the meat using the microwave only.

## Bakes, gratins, toast with toppings

### Notes

- The values in the table apply to food placed in a cold oven.
- Use large flat ovenware for bakes and gratins. Food takes longer to cook in narrow, deep containers and browns more on top.
- Place the bake in microwaveable ovenware on the wire rack.
- Leave bakes and gratins to cook in the oven for a further 5 minutes after switching off.















- Use a 4 to 5 cm deep ovenproof dish for bakes, potato gratins and lasagne.
- Place soufflés in individual moulds or in a deep ovenproof dish. Preheat the cooking compartment.
- Toast with topping: lay 4 slices next to each other in the centre of the universal pan. Distribute 12 slices evenly over the universal pan.

Bakes, gratins, toast with toppings	Accessories	Level	Type of heating	Temperature in °C, grill setting	Microwave power in watts	Cooking time in minutes
Bake, sweet, approx. 1.5 kg	Ovenware without lid, wire rack	1		140-160	360 W	25-35
Soufflé	Ovenware without lid, wire rack	1		160-180	-	40-50
Soufflé in individual moulds	Wire rack	1		200-210	-	12-17
Pasta bake, approx. 1 kg	Ovenware without lid, wire rack	1		140-160	600 W	20-30
Lasagne, approx. 2 kg	Ovenware without lid, wire rack	2		180-200	600 W	20-30
Potato gratin made from raw ingredients, approx. 1.1 kg	Ovenware without lid, wire rack	1		170-190	600 W	20-25
Toast with topping, 4 slices	Universal pan	2		3	-	8-13
Toast with topping, 12 slices	Universal pan	2		3	-	9-14

## Convenience products

### Notes

- Please observe the instructions on the packaging.
- The values in the table apply to food placed in a cold oven.
- Do not lay chips, croquettes or potato röstis on top of each other.
- Turn fish fingers, chicken goujons, nuggets and veggie burgers halfway through the cooking time.
- Place cream gateau on the oven floor without accessories, level 0.

Convenience products	Accessories	Level	Type of heating	Temperature in °C	Microwave power in watts	Cooking time in minutes
Pizza with thin base	Universal pan	1		210-230	-	20-25
Pizza with deep-pan base	Universal pan	1		200-220	90 W	15-25
Mini pizza	Universal pan	1		210-230	-	15-20
Pizza baguette	Universal pan	2		180-190	-	15-20
Chips	Universal pan	1		220-230	-	20-25
Croquettes	Universal pan	1		200-220	-	25-35
Rösti, stuffed potato pockets	Universal pan	2		200-220	-	25-35
Bread rolls, baguette	Wire rack	2		200-220	-	15-20
Pretzels, dough	Universal pan*	2		190-210	-	20-25
Part-cooked rolls or baguette	Wire rack	2		140-150	-	12-15
Fish fingers	Universal pan	2		190-210	180 W	10-15
Chicken goujons, nuggets	Universal pan	2		190-210	360 W	15-20
Veggie burgers	Universal pan	2		200-220	180 W	15-25
Strudel	Universal pan	2		200-220	90 W	20-25
Lasagne	Wire rack	2		200-210	180 W	18-23

\* Line the universal pan with greaseproof paper.

The greaseproof paper must be suitable for these temperatures.

## Test dishes

The quality and function of microwave combination appliances are tested by testing institutes using the following dishes.

According to the standards EN 60705, IEC 60705/DIN 44547 and EN 60350 (2009)



### Defrosting with the microwave

Dish	Microwave power setting in watts, cooking time in minutes	Note
Meat	180 W, 5 mins + 90 W, 10-15 mins	Place 22 cm Pyrex dish on the wire rack at level 1. After approx. 10 minutes, remove the defrosted meat.

### Microwave cooking

Dish	Microwave power setting in watts, cooking time in minutes	Note
Custard	360 W, 10 mins + 180 W, 20-25 mins	Place Pyrex dish on the wire rack at level 1.
Sponge	600 W, 8-10 mins	Place 22 cm Pyrex dish on the wire rack at level 1.
Meat loaf	600 W, 20-25 mins	Place Pyrex dish on the wire rack at level 1.

### Combined microwave cooking

Dish	Microwave power setting in watts, cooking time in minutes	Type of heating	Temperature °C	Note
Potato gratin	600 W, 20-25 mins		170-190	Place 22 cm Pyrex dish on the wire rack at level 1.
Cake	180 W, 15-20 mins		180-200	Place 22 cm pyrex dish on the wire rack at level 1.
Chicken*	360 W, 30-35 mins		200-220	Turn after 15 minutes.







\* Slide the wire rack in at level 2 and the universal pan in at level 1.

## Baking



### Notes

■ The values in the table apply to food placed in a cold oven.

■ Apple pie: place the dark springform cake tins diagonally alongside one another.

	Ovenware	Level	Type of heating	Temperature °C	Baking time in minutes
Viennese whirls	Universal pan	2		160-180	20-30
	Universal pan	2		150-170	20-30
Small cakes	Universal pan	2		150-170	25-35
	Universal pan	2		140-160	25-35
Hot water sponge cake	Springform cake tin on the wire rack	1		170-180	30-40
Yeast cakes on a baking tray	Universal pan	2		170-190	45-55
Apple pie	2 x 20 cm springform cake tins + Universal pan	1		180-200	70-90

## Grilling

	Accessories	Level	Type of heating	Grill setting	Cooking time in minutes
Toasting bread*	Wire rack	3		3	1-2
12 beefburgers**	Wire rack + universal pan	3 1		3	30

\* Preheat for 5 minutes.

\*\* Turn halfway through the cooking time.

## Acrylamide in foodstuffs

### Which foods are affected?

Acrylamide is mainly produced in grain and potato products that are heated to high temperatures, such as potato crisps,

chips, toast, bread rolls, bread, fine baked goods (biscuits, gingerbread, cookies).

### Tips for keeping acrylamide to a minimum when preparing food

General	Keep cooking times to a minimum. Cook meals until they are golden brown, but not too dark. Large, thick pieces of food contain less acrylamide.
Baking biscuits Oven chips	Max. 200 °C in Top/bottom heating or max. 180 °C in 3D hot air or hot air mode. Max. 190° C in Top/bottom heating or max. 170 °C in 3D hot air or hot air mode. Egg white and egg yolk reduce the formation of acrylamide. Distribute thinly and evenly over the baking tray. Cook at least 400 g at once on a baking tray so that the chips do not dry out.

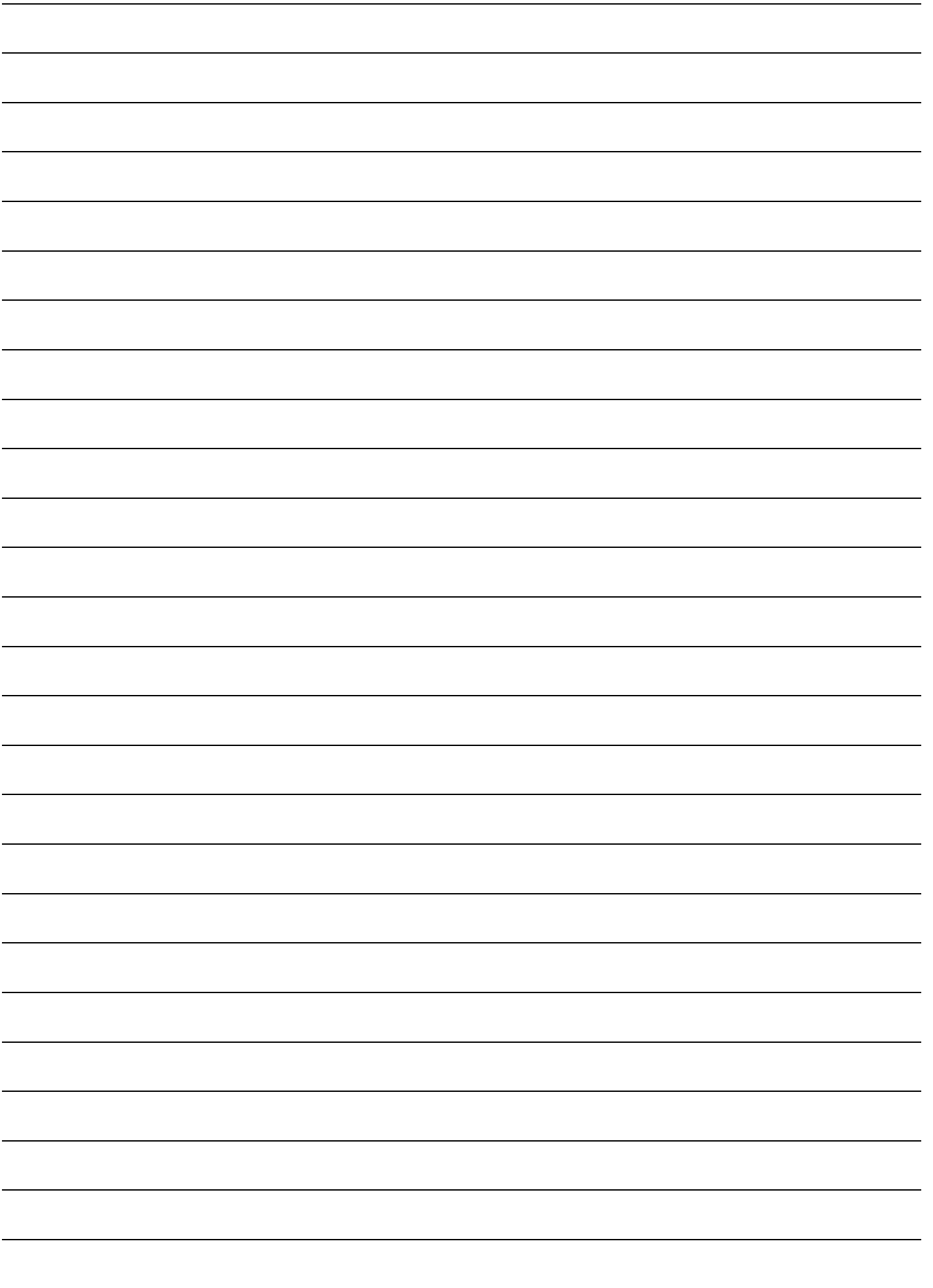

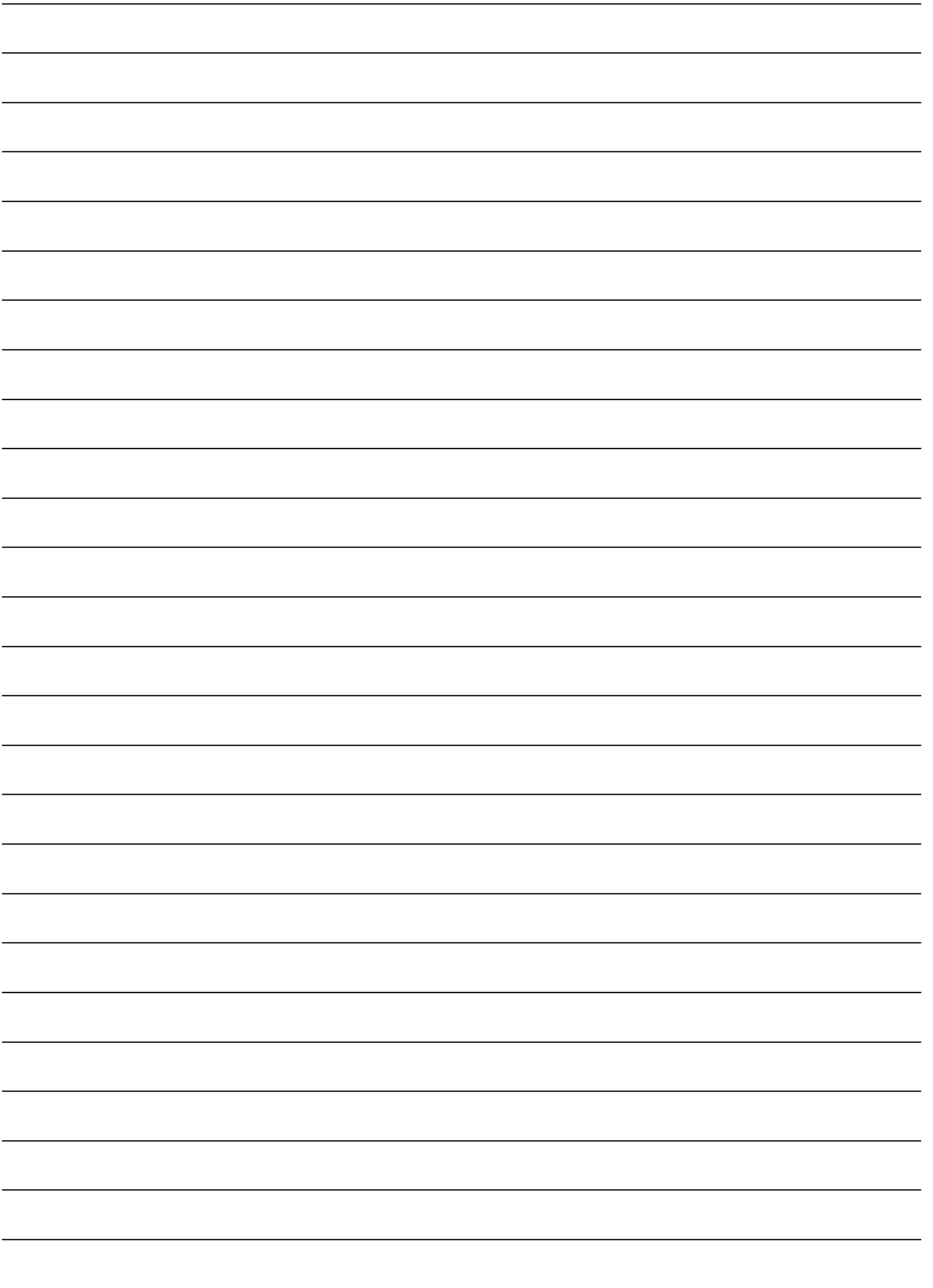



Robert Bosch Hausgeräte GmbH  
Carl-Wery-Straße 34  
81739 München  
DEUTSCHLAND