



**A GUIDE TO USE,  
INSTALLATION AND REGULATION  
OF YOUR COOKERS**

**Models: EG800FS2  
ESG800GUSX**



---

**MANUFACTURED BY: TECNO**

The appliance was designed and made in accordance with the European standards listed below:

=> EN 30-1-1, EN 30-2-1 and EN 437 plus subsequent amendments (gas)

=> EN 60 335-1 and EN 60 335-2-6 (electrical) plus relative amendments

The appliance complies with the prescriptions of the European Directives as below:

=> 2006/95 EC concerning electrical safety (BT).

=> 2004/108 EC concerning electromagnetic compatibility (EMC)

=> 2009/142/ EC concerning gas safety.

---

Oven accessories that could come into contact with foodstuffs are made with materials that comply with the provisions of the 89/109 EC directive dated 21/12/88.

---

This product complies with EU Directive 2002/96/EC.

The crossed-out dustbin symbol reported on the appliance indicates that the appliance must be disposed of separately from other domestic refuse at the end of its useful life. It must therefore be delivered to a waste recycling centre specifically for electric and electronic equipment or returned to the retailer at the moment of purchase of a new equivalent appliance.



The user is responsible for delivering the appliance to the appropriate collection centre at the end of its useful life, Failure to do so may result in a fine, as provided for by laws governing waste disposal.

Differential collection of waste products for eventual recycling, treatment and environmentally friendly disposal helps reduce possible negative effects on the environment and health, and also enables the materials making up the product to be recycled.

For more detailed information on the available refuse collection systems, refer to the local Municipal Solid Waste disposal centre or the shop where the product was purchased.

Producers and importers are responsible for fulfilling their obligations as regards recycling, treatment and environmentally friendly disposal by directly or indirectly participating in the collection system.

## ASSISTANCE AND SPARE PARTS

the best functioning results.

Any subsequent repairs or adjustments that may be necessary must be done with the maximum of care and attention by authorised personnel.

For this reason we recommend you always contact us (refer below), specifying the brand, model, serial number and type of problem you are having with it. You will find the relative data printed on a label affixed on the appliance and on the label affixed to the packing box.

### IMPORTANT NOTICE

The manufacturer shall not be held responsible for any damage to persons or property caused by incorrect installation or use of the appliance.

For prompt warranty service, please ensure that the warranty registration form is completed and return posted to us.

A duplicate data label and wiring diagram are contained in this booklet. Please attach these labels to an accessible surface near by the appliance for easy reference.

You can purchase original spare parts from authorised dealers or direct from us.

## DOMESTIC USE ONLY

## CONTENTS

<b>ASSISTANCE AND SPARE PART</b>	<b>3</b>
<b>IMPORTANT NOTES AND PRECAUTIONS FOR USE</b>	<b>4</b>
<b>DESCRIPTION OF THE APPLIANCE</b>	<b>5</b>
<b>INSTRUCTIONS FOR THE USER</b>	<b>6-14</b>
<b>TROUBLESHOOTING</b>	<b>14</b>
<b>INSTRUCTIONS FOR THE INSTALLER</b>	<b>17-25</b>
<b>TECHNICAL FEATURES</b>	<b>26-32</b>

## IMPORTANT NOTES AND PRECAUTIONS FOR USE

You have purchased one of our products for which we thank you. We are confident that this new appliance, modern, functional and practical, made with top quality materials, will meet all your demands. This new appliance is easy to use but before installing and using it, **it is important to read this handbook through carefully.** It provides information for a safe installation, use and maintenance. Keep this handbook in a safe place for future reference.

**The manufacturer reserves the right to make all the modifications to its products that it deems necessary or useful, also in your interests, without prejudicing its essential functional and safety characteristics.** The manufacturer cannot be held responsible for any inaccuracies due to printing or transcription errors that may be found in this handbook.

**N.B.:** the pictures shown in the figures in this handbook are purely indicative.

- The installation, adjustments, conversions and maintenance operations listed in section «INSTRUCTIONS FOR THE INSTALLER» must only be carried out by authorised personnel .
- The installation of all-gas and combi appliances must comply with the standards in force.
- The appliance must only be used for its original purpose, that is, cooking for domestic use. Any other use is considered improper and, as such, dangerous.
- The manufacturer cannot be held responsible for any damage to persons or property resulting from an incorrect installation, maintenance or use of the appliance.
- Once the packaging has been

removed from the outer surfaces and the various inner parts, thoroughly check that the appliance is in perfect condition. If you have any doubts do not use the appliance and call in an authorised person.

- The packaging materials used (cardboard, plastic bags, polystyrene foam, nails, etc.) must not be left within easy reach of children because they are a potential hazard source. All packaging materials used are environmentally-friendly and recyclable.
- The electrical safety of this appliance is only guaranteed if it is correctly connected to a suitable earth system, as prescribed by the electrical safety standards. The manufacturer disclaims all responsibility if these instructions are not followed. Should you have any doubts, seek the assistance of an authorised person.
- Before connecting the appliance ensure that the rating plate data corresponds to that of the gas and electricity supply (see section «TECHNICAL FEATURES»).
- **NOT FOR USE IN MARINE CRAFT, CARAVANS OR MOBILE HOMES UNLESS EACH BURNER IS FITTED WITH A FLAME SAFEGUARD.**
- **DO NOT MODIFY THIS APPLIANCE**
- **DOMESTIC USE ONLY**

During use the appliance becomes hot. Care should be taken to avoid touching heating elements inside the oven.



## IMPORTANT NOTES AND PRECAUTIONS FOR USE

**WARNING** - Accessible parts may become hot during use. To avoid burns young children should be kept away.

**WARNING** - Accessible parts may become hot when the grill is in use. Children should be kept away.

• The oven door glass and the accessible parts will become hot when in use. To avoid burns and scalds young children should be kept away.

• **Do not** use this appliance as a space heater.

• **Do not** touch any electrical appliance if hands or feet are wet or damp.

• **Do not** use the appliance bare footed.

• **Do not** pull the power lead to take the plug out of the socket.

• **Do not** leave the appliance outside under the sun, rain, etc.

• This appliance is not intended for use by persons (including children) with reduced physical, sensory or mental capabilities, or lack of experience and knowledge, unless they have been given supervision or instruction concerning use of the appliance by a person responsible for their safety.

• Children should be supervised to ensure that they do not play with the appliance. Cleaning and user maintenance shall not be made by children

• **WARNING** - In order to prevent accidental tipping of the appliance, for example by a child climbing over the open oven door, or too high weights are leant on the open oven door, two chains must be screwed on the back on the cooker and fixed to the wall with hooks. Ensure the chains are taut. Please refer to instructions for installation..

• Before cooking for the first time, ensure the oven is empty and its door closed, heat the oven at maximum temperature for two hours. This will allow the protective coating on the interior of the oven to be burnt off and dissipate the associated smells. Ensure adequate ventilation in the kitchen whilst burning off and don't be alarmed by a little bit of smoke during this process.

• Unattended cooking on a hob with fat or oil can be dangerous and may result in fire.

• Never try to extinguish a fire with water, but switch off the appliance and then cover flame e.g. with a lid or a fire blanket.

• Danger of fire: Do not store items on the cooking surfaces

• **Do not** use harsh abrasive cleaners or sharp metal scrapers to clean the oven glass door since they can scratch the surface, which may result in shattering of the glass.

• **NEVER** use sponges or abrasive products, and solvents to remove stains or adhesives on the painted or stainless steel surfaces.

• Switch off the oven before removing the fan guard for cleaning. Replace the guard after cleaning in accordance with the instructions.

• The oven can be equipped with temperature probe. Only use the temperature probe recommended for this oven by our Service Centre.

• Remove any spillage from the lid before opening.

## IMPORTANT NOTES AND PRECAUTIONS FOR USE

- The appliance is not intended to be operated by means of an external timer or separate remote-control system
- Ensure that the appliance is switched off before replacing the lamp to avoid the possibility of electric shock..
- The cookers can be equipped with a small compartment under the oven that can be used for storing things Remember that the surfaces become hot, it is strictly forbidden to place inflammable materials inside.
- **Do not** use a steam cleaner to clean a hob, oven or range.
- The appliance is to be placed directly on the floor and shall not be mounted on a base.
- If the appliance is fitted with a glass lid, this can shatter when heated. Turn off all the burners or disconnect all the plates, and allow them to cool before closing the lid (fig.3)
- **Not suitable for installation or operation with aftermarket lids or covers**
- Avoid using the oven as a larder or as a saucepan cupboard when you are not using it for cooking: if the oven is turned on accidentally it could cause damage and accidents.
- If you are using an electrical socket near the appliance, make sure that the cables are not touching the cooker and are far enough away from all hot parts.
- When you have finished using the appliance check that all the controls are in the off or closed position, checking that the “0” of the knob corresponds to the “•” symbol serigraphed on the front panel.
- Switch off the electrical supply before you start cleaning or servicing the appliance.
- In the case of a failure or malfunction, turn the appliance off and switch off the electrical supply and do not tamper with it. All repairs or adjustments must be carried out with maximum care and the proper attention of an authorised person.
- For this reason we recommend you call our Service Centre.

## DESCRIPTION OF THE APPLIANCE

### PRESENTATION

Our cooker is fitted with a fully gas hotplate.

Each knob on the front panel has a diagram printed above it showing to which burner it refers. The combination of the different sized burners offers the possibility of various types of cooking.

Our cookers are fitted with a gas oven burner and an electric grill. With the aid of the fan the oven can be used for natural convection or forced convection cooking.

To guarantee the customer a good and safe use of the appliance, the cookers have equipped with a safety temperature device which automatically turns on in case the main thermostat fails to work.

In such an event, the electricity is interrupted temporarily: **do not attempt to repair it yourself but turn the appliance off and contact your nearest Assistance Centre.**

The oven walls are fitted with various guide bars or runners (fig. 1) on which the following accessories can be placed. **Supply and quantities vary from model to model (fig. 2):**

- **oven shelf rack (Gc).** Ensure shelf is located with dish and tray stop pointing upwards and at rear of oven.
- **drip tray (V)**
- **handle (D)**
- **drip tray grid (Gv)**

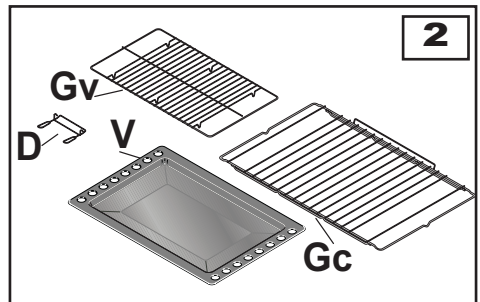
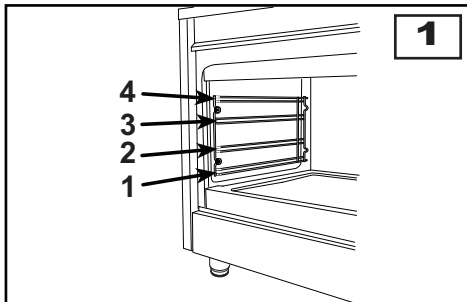



# INSTRUCTIONS FOR THE USER

## DESCRIPTION OF THE CONTROLS

### HOB GAS BURNER KNOB (A)

By rotating the knob in an anticlockwise direction, the following symbols appear:

- 0 = Closed position
-  = "Full on" position
-  = "Reduced rate or Low" position

### GAS OVEN/ELECTRIC GRILL THERMOSTAT KNOB (B)

By rotating the knob in an anticlockwise direction, the following functions appear:

- 0 = Closed position
- from Min. to Maxi (260°C) = Oven temperatures

Turn the knob clockwise if you want to use the electric grill 

OVEN FAN BUTTON 

OVEN LIGHT SWITCH 

### LIGHT INDICATING OVEN ELECTRICAL COMPONENTS ACTIVATION

If present, when lit, it indicates that an electric component is inserted

### LIGHT AND FAN COMMUTATOR KNOB (C)

By turning the knob clockwise or anti clockwise we will find the following symbols.

*In the models with rotisserie, its function is together with light*

### TIMER (D)

To set cooking time, first wind the timer up by turning it completely once from left to right and then back to the number of minutes you want. The timer will ring when the set time has elapsed.

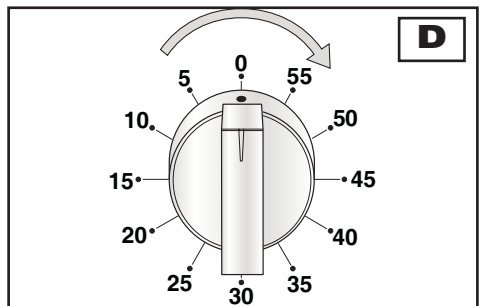
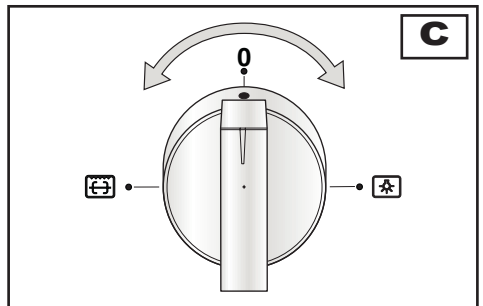
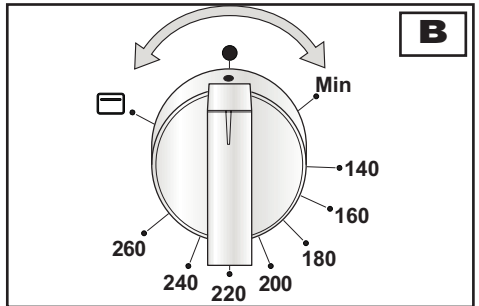
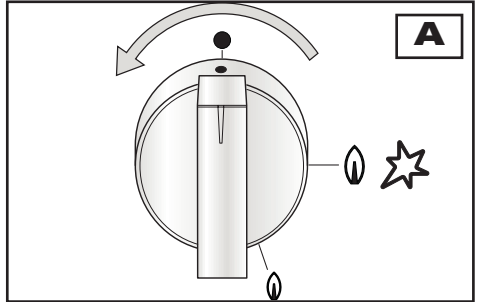





# INSTRUCTIONS FOR THE USER

## HOB: GENERAL NOTES ON SAFETY

- When using the burners, do not leave the appliance unsupervised. Ensure that children and the infirm do not play with the appliance. In particular, make sure that pan handles are positioned correctly and supervise the cooking of foods which use oils and fats, as these are highly inflammable.
- Do not use aerosols or sprays near the appliance when it is in use.
- Even after use, the burners remain hot for a long period; to avoid burning, do not place hands or other objects on them.
- After using the appliance, ensure that all the controls are in the closed or off position.

## AUTOMATIC ELECTRIC IGNITION OF COOKTOP BURNERS

Push and turn the knob (A) which corresponds to burner to be ignited and turn anti clockwise to the "Full On"   position.

Automatically the ignition spark shoots. If there is no electric power the burner may be lit with matches.

## OPTIMUM USE OF COOKTOP BURNERS

In order to achieve maximum efficiency with minimum gas consumption it is useful to remember:

- Do not use large burners with pans of small diameter in order to avoid flames spreading wider than pans (consult the following table) and always use pans with lids (fig. 3).
- When the boiling point is reached, it is best to turn the knob to the "Low position".
- Avoid using over sized pans that may radiate excessive heat and cause damage to surrounding surfaces such as bench tops and glass lid.
- The appliance is equipped with a particular pan support (1) on which must be put the wok support (2). To ensure stability, position the notch (A) of wok support on the pan support fingers as indicated in fig. 4.
- Do not place anything, e.g. flame tamer, asbestos mat, between pan and pan support, as serious damage to the appliance may result (fig. 5).
- Locate pan centrally over the burner so that is stable and does not overhang the appliance (fig. 6).
- If gas burns with a yellow flame, do not continue to use burner and arrange for service.
- Do not use burners without the proper pan support or wok stand, as this will concentrate and deflect the heat onto the hotplate (fig.7) and surrounding surfaces.
- Use only a wok support supplied or recommended by the manufacturer of the appliance (fig. 8).

## ABNORMAL OPERATION

Any of the following are considered to be abnormal operation and may require servicing:

- Yellow tipping of the hob burner flame.
- Sooting up of cooking utensils.
- Burners not igniting properly.
- Burners failing to remain alight.
- Burners extinguished by the oven door.
- Gas valves, which are difficult to turn.

In case the appliance fails to operate correctly, contact our Service Centre.

**Warning: Servicing should be carried out only by authorised personnel.**

Burners	Wok	Large	Medium	Small
Ø pan cm	22 - 24	20 - 22	16 - 18	12 - 14

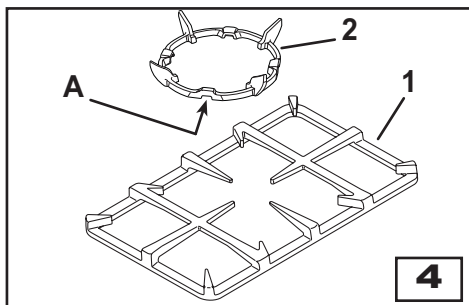
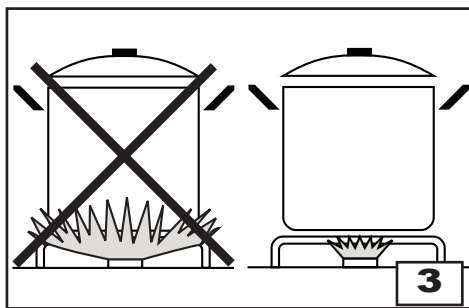

# INSTRUCTIONS FOR THE USER

## OVEN: GENERAL SAFETY INSTRUCTIONS

- Do not leave the oven unsupervised during use. Ensure that children and the infirm do not play with the appliance.
- Do not spray aerosols in the vicinity of this appliance while it is operating.
- Always grip the centre of the oven door when opening. Do not practice excessive pressures on the door when it is open.
- Do not store or use flammable liquids or items in the vicinity of this appliance.
- Do not worry if condensation forms on the door and on the internal walls of the oven during cooking. This does not compromise its efficiency.
- When opening the oven door, be very careful of scalding vapours.
- During use the appliance becomes hot. Care should be taken to avoid touching heating elements inside the oven. Wear oven gloves when placing or removing pans from the oven or use the handle (D) (fig. 2) provided. Hook the handle to the edge of the tray and pull it out, slightly lifting it as you do so.
- When inserting or removing food from the oven, check that excess juices do not overflow onto the oven base (oils and fats are highly inflammable when overheated).
- Use containers that will resist the temperatures indicated on the thermostat knob.



**HOT SURFACE**

- Never cover the base of the oven or the oven shelf with aluminium foil or other materials, as this creates a fire hazard.
- When grilling always put a little water in the grill pan. The water prevents the grease from burning and from giving off bad smells and smoke. Add more water during grilling to compensate for evaporation.
- After using the appliance ensure that all the controls are in the off position.
- **WARNING - During and after use, the oven door glass and the accessible parts will become hot when in use. To avoid burns and scalds children should be kept away.**

## WHAT TO DO THE FIRST TIME YOU USE THE OVEN

- Remove all protective wrapping materials from the appliance and labels from the oven door.
- Remove combustible materials from the warming compartment before commissioning the cooker.
- Before cooking for the first time, **place the programming accessory, on the manual position** and, heat the oven at maximum temperature for 2 hours. This will allow the protective coating on the interior of the oven to be burnt off and expel the associated smells. Ensure adequate ventilation in the kitchen whilst burning off and don't be alarmed by a little bit of smoke during this process. At the end of this time period, allow the appliance to cool down and then clean the interior using hot water and a delicate detergent. Also wash all the accessories (grills, trays, spit roast, etc.) before use.

**Prior to any cleaning, disconnect the appliance from the electricity mains.**

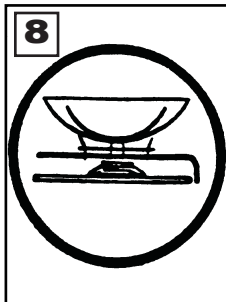
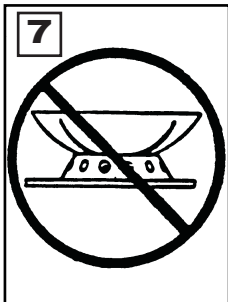
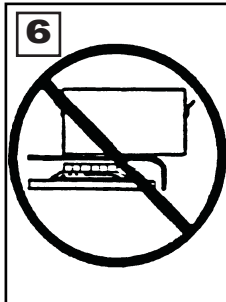
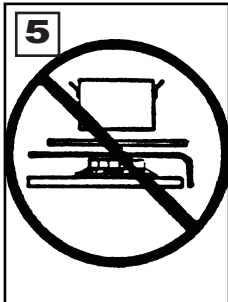

# INSTRUCTIONS FOR THE USER

## HOW TO USE GAS OVEN

The oven burner can be fitted with a safety thermocouple so, once the burner has been lit, keep the knob pressed for about 15 seconds. If, at the end of this time, the burner fails to light, release the knob and wait at least 1 minute before trying again. Should the burner turn out accidentally, turn the knob round to the closed position and wait at least 1 minute before lighting it again.

### MANUAL IGNITION OF THE OVEN BURNER

Open the oven door press and turn the oven knob counterclockwise until it reaches to the maximum temperature position, simultaneously placing a lighted match to the burner through the hole (B) (fig. 9).

### AUTOMATIC ELECTRIC IGNITION OF OVEN BURNER.

Open the oven door push lightly the oven knob and turn counterclockwise until it reaches to the maximum temperature position, then depress the knob. Automatically the ignition spark shoots. Matches can be used to light the burners in a blackout.

After the oven burner has been lit (check through the opening (C) (fig. 9) that it has ignited), adjust the temperature according to your needs and leave open the oven door for 2 to 3 minutes. Close the door gently so the flames will not blow out and wait 15 minutes before putting any food in to cook. Our oven can cook all foods (meat, fish, bread, pizza, cakes, etc.).

### USING THE OVEN

Having ignited the oven, the gas control knob should be adjusted to the desired temperature and the oven door left open for 2 to 3 minutes and then gently close the door to avoid extinguishing the flame. Preheat the oven for approximately 15 minutes.

Your appliance's heat circulation pattern is quite different to many other cookers. It employs an ingenious, natural, "Rapid Draught" convection system. Hot air is efficiently circulated through the oven very quickly producing relatively even heat zoning.

With planning and a clear understanding of your appliance's characteristics and capabilities you will be able to produce superb results and larger than normal quantities. However in order to obtain maximum efficiency it is useful to remember:

- Cooking times and shelf positions will probably be different from your previous oven. The size and type of dishes used will affect cooking times and the use of aluminium foil will increase cooking times. We recommend doing a test bake, and comparing the times in the time and temperature chart to some of your favourite recipes. Add 10 to 15 degrees C when cooking larger quantities. Shelves are numbered from

the bottom (fig. 1).

- Be sure to remove the enamelled grill tray when the oven is in use. It is not intended to be used for baking or roasting purposes and it can interfere with heat distribution in the oven.
- Slightly more heat is generated from the bottom of the oven upwards, with the top shelf being the marginally cooler zone. This is the reverse of other ovens you may have used and some minor adjustment to your cooking methods with some dishes may be required. Most baking would be done on the middle shelves, with the lower shelves being used for a greater degree of base browning.
- Always preheat the oven when cooking frozen or chilled foods.
- Best results are achieved when preparing large quantities or using two shelves simultaneously by positioning serves with an «air space» around. More even cooking can be made possible if two medium sized baking trays are used per shelf, leaving a 3-4 cm «air space» between the trays and from the trays to the oven wall. A single larger tray may divert or block the usual flow of hot air around the oven. When using two shelves simultaneously allow an «air space» by leaving one shelf space empty between.
- You can plan batch baking to make the most efficient use of the hotter and cooler zones, by cooking a different food requiring slightly different temperature on each shelf e.g. small cakes and slab cakes, or two different types of biscuits (refer to the chart on pag. 12).
- Light weight, uncoated aluminium trays and pans are recommended for general cooking. Heavy gauge and dark coloured utensils do attract extra heat and may be unsuitable for some foods.
- The aluminium can be easily corroded if it comes into contact with organic acids present in the foods or added during baking (vinegar, lemon juice). Therefore it is advised not to put directly the foods on aluminium or enamelled trays, but ALWAYS use the proper oven paper.

Contact our Service if assistance is required with cooking results or thermostat operation appears incorrect.

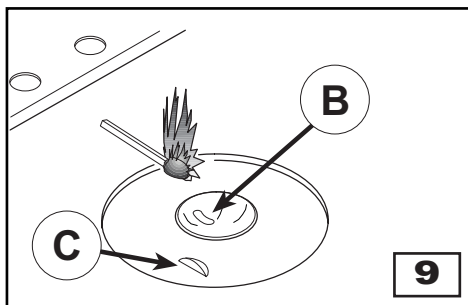

# INSTRUCTIONS FOR THE USER

## TIME AND TEMPERATURE CHART

The above table gives guidelines for cooking a range of different foods, individual food, or personal preferences may slightly vary the oven position, temperature and cooking time from those suggested.

Please note that:

- All cooking temperatures stated refer to a preheated oven (allow 15 minutes for preheating).
- The shelves are numbered from the bottom i.e. the top shelf is Shelf 3, bottom shelf is Shelf 1.
- If baking a larger quantity than the example shown in the chart, slightly increase temperatures and/or time.
- If baking a smaller quantity than the example, slightly decrease the temperature and/or time.
- Remember to remove grill tray from oven before baking in oven.

FOOD ITEM	QUANTITY	OVEN POSITION	TEMPERATURE °C	APPROXIMATE TIME
<b>CAKES</b>				
Patty cakes	20	Shelf 2 or 3	190	15-20 mins.
Sponges	1 or 2	Shelf 2 or 3	190	20-25 mins
Butter cake - slab	1	Shelf 2 or 3	190	30-35 mins.
Boiled fruit cake - 20 cm tin	1	Shelf 2 or 3	160	2 hrs.
Rich fruit cake - 20 cm tin	1	Shelf 2 or 3	150	4 hrs.
<b>SCONES</b> - plain	20	Shelf 2	240	10-12 mins.
<b>BISCUITS</b>				
Anzacs	24	Shelf 2 or 3	150	20 mins.
Burnt butter biscuits	40	Shelf 2 or 3	180	25 mins.
<b>MERINGUE</b> - small	20	Shelf 2 or 3	125	1-1½ hrs. allow to cool in oven
<b>PASTRIES</b>				
Custard tart - 23 cm	1	Shelf 3	220/180	10/40-50 mins.
Fruit pies - biscuit pastry, double crust cooked filling	1	Shelf 3	210/190	15/15-20 mins.
Sausages rolls	20	Shelf 2 or 3	220	20-25 mins.
<b>PIZZA</b> - yeast dough 30 cm	1	Shelf 3	240	20-25 mins.
<b>OVEN MEAL</b>				
Roast meat & vegetables		Shelf 2 or 3	210	as requested
Fruit pies	2	Shelf 2 or 3		50-60 mins.
<b>BREAD</b>	1 loaf	Shelf 3	200	35-40 mins.

## RETAIN THIS CHART FOR EASY REFERENCE

### ROAST MEATS

Meats are generally roasted in the centre of the oven (shelf 3) but the position may be varied according to the size of the meat and the other foods to be cooked at the same time.

A moderate temperature can be used (200°C) although superior results are often achieved by cooking meat quickly at a high temperature e.g. 250°C for 30 minutes to sear the meat, then complete the cooking on a moderate heat. Turkey or other very large joints of meat may be cooked at lower than moderate temperatures.

# INSTRUCTIONS FOR THE USER

## AUTOMATIC ELECTRIC IGNITION OF THE GRILL BURNER

Automatic ignition is achieved by firstly, **fully opening the oven door** and then pushing and turning the gas control knob (B) clockwise to the grill setting, then depress the knob. Automatically the ignition spark shoots. Continue to push gas control knob for 15 seconds after ignition has occurred. If ignition does not occur, turn gas control knob off, open the warming compartment door and wait 60 seconds to allow gas to disperse, then repeat ignition procedure.

## MANUAL IGNITION OF THE GRILL BURNER

In the event of power failure or component malfunction, manual ignition of the grill can be achieved by repeating the above steps, but instead of pushing control knob, placing a lit match at the grill burner.

## USING THE GRILL

- The grill is located in the top of the oven and makes for an extremely versatile and controllable method of cooking.
- Preheat the grill for a few minutes for quicker cooking and more succulent results.
- The food should be seasoned before cooking. Oil or melted butter should also be spread on the food before it is cooked.
- Foods to be grilled should be placed on the grill rack positioned in the drip tray (fig. 2) or directly on the shelf (fig. 10).  
Then place this on the oven shelf required and **use the drip pan to catch the gravy**.
- When grilling always put a little water in the grill pan. The water prevents the grease from burning and from giving off bad smells and smoke. Add more water during grilling to compensate for evaporation.

- **With gas grill the oven door must be left partially opened at its preset hold position and you must ensure that the protective heat guard (fig. 10) is correctly fitted to protect the controls and fascia panel. Take care when later removing the hot protective heat guard.**
- The grill offers a fixed heat setting but, a great degree of heat control is possible by selecting the most suitable oven shelf position for grilling the particular food. The lower the shelf, the less intense the heat. This ability to adjust shelf positions also allows for a range of bulky foods to be prepared under the grill which ordinarily couldn't be prepared in a standard grill compartment.
- Use Shelf 3 for thick cuts of meat, fish fillets or chicken pieces. Use Shelf 2 for larger portions of foods, such as half chicken, whole fish or browning the tops of casserole dishes etc.
- The large grill tray allows an array of foods to be prepared under the grill. The most intense heat is directly beneath the grill burner. Foods requiring more gentle heat can be placed around the perimeter of the tray where heat is not quite as intense, for example, seafood or vegetable kebabs, savouries, warming hamburger buns or keeping foods warm.

## COOKING WITH THE AID OF THE FAN

Some cookers can be equipped with a fan installed in the rear part of the oven compartment. This can be activated by pressing the fan switch .   
After the fan has been activated, the heat will be quickly and regularly distributed throughout the oven, thus allowing different foods to be evenly cooked on several shelves at the same time, also reducing the cooking times.

**The fan cannot be activated during the gas grill**

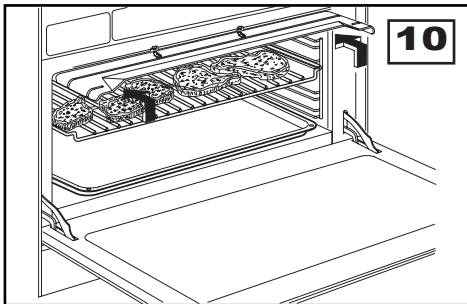

# INSTRUCTIONS FOR THE USER

## USEFUL COOKING TIPS

### Cakes and bread:

- Heat the oven for at least 15 minutes before you start cooking bread or cakes.
- Do not open the door during baking because the cold air would stop the yeast from rising.
- When the cake is cooked turn the oven off and leave it in for about 10 minutes.
- Do not use the enamelled oven tray or drip pan, supplied with the oven, to cook cakes in.
- How do you know when the cake is cooked? About 5 minutes before the end of cooking time, put a cake tester or skewer in the highest part of the cake. If it comes out clean the cake is cooked.
- And if the cake sinks? The next time use less liquids or lower the temperature 10°C.
- If the cake is too dry: Make some tiny holes with a toothpick and pour some drops of fruit juice or spirits on it. The next time, increase the temperature 10°C and set a shorter cooking time.
- If the cake is too dark on top: the next time put the cake on a lower shelf, cook it at a lower temperature and longer.
- If the top of the cake is burnt: cut off the burnt layer and cover with sugar or decorate it with cream, jam, confectioner's cream, etc..
- If the cake is too dark underneath: the next time place it on a higher shelf and cook it at a lower temperature.
- If the cake or bread is cooked nicely outside but is still uncooked inside: the next time use less liquids, cook at a lower temperature and longer.
- If the cake will not come out of the tin: slide a knife around the edges, place a damp cloth over the cake and turn the tin upside down. The next time grease the tin well and sprinkle it with flour or bread crumbs.
- If the biscuits will not come away from the baking tray: put the tray back in the oven for a while and lift the biscuits up before they cool. The next time use a sheet of baking parchment to prevent this happening again.

### Meat:

- If, when cooking meat, the time needed is more than 40 minutes, turn the oven off 10 minutes before the end of cooking time to exploit the residual heat (energy saving).
- Your roast will be juicier if cooked in a closed pan; it will be crispier if cooked without a lid.
- Normally white meat, poultry and fish need medium temperatures (less than 200°C).
- To cook "rare" red meats, high temperatures (over 200°C) and short cooking times are needed.
- For a tasty roast, lard and spice the meat.
- If your roast is tough: the next time leave the meat to ripen longer.
- If your roast is too dark on top or underneath: the next time put it on a higher or lower shelf, lower the temperature and cook longer.
- Your roast is underdone? Cut it in slices, arrange the slices on a baking tray with the gravy and finish cooking it.

### Grilling:

- Sparingly grease and flavour the food before grilling it.
- Always use the grill pan to catch the juices that drip from the meat during grilling.
- Always put a little water in the drip pan. The water prevents the grease from burning and from giving off bad smells and smoke. Add more water during cooking because it evaporates.
- Turn the food half way through cooking.
- If you are grilling fatty poultry (goose) pierce the skin under the wings after about half an hour so the fat can drip away.

**The aluminium can be easily corroded if it comes into contact with organic acids present in the foods or added during baking (vinegar, lemon juice). Therefore it is advised not to put directly the foods on aluminium or enamelled trays, but ALWAYS use the proper oven paper.**

# INSTRUCTIONS FOR THE USER

## CLEANING AND MAINTENANCE

- Prior to any maintenance work or cleaning, disconnect the appliance from the electricity mains.
- Do not use a steam cleaner to clean this appliance.
- Do not wash the parts if they are still hot.
- Do not use metal pads, abrasive powders or corrosive spray products for cleaning
- Do not leave vinegar, coffee, milk, salty water or the juice of lemon or tomato on enamelled surfaces for any length of time.
- Switch off the oven before removing the fan guard for cleaning. Replace the guard after cleaning

### HOT PLATE

To keep the surface of the hob and the various components in pristine condition (grill, enamelled covers, burner heads and flame diffusers, it is very important to wash them in warm soapy water, rinse and dry them well after each use.

### WARNINGS

- Check that the heads burners and the relative burner caps, are correctly positioned in their housings (fig. 11). Take care not to interfere with the ignition spark plugs or flame failure devices.
- If you find a tap is difficult to open or close do not force it but call for technical assistance urgently.

### STRUCTURE

All the cooker parts (in enamelled or painted metal, steel, or glass) should be cleaned frequently with warm soapy water and then rinsed and dried with a soft cloth.

DO NOT use rough or abrasive materials or sharp metal scrapers to clean the oven glass doors as they could scratch and cause the glass to break

NEVER use sponges or abrasive products, and aromatic or aliphatic solvents to remove stains or adhesives on the painted or stainless steel surfaces.

### OVEN CAVITY

**Do not spray or wash the thermostat bulb with acid based products (check the product label before use). The manufacturer cannot be held liable for any damage caused by incorrect cleaning.**

The oven cavity should be cleaned after each use to remove cooking residuals and or grease or sugar which, if burnt on when the oven is used again, will form deposits or unremovable stains as well as unpleasant smells.

To maintain the shine of the enamelled parts, clean them with warm soapy water, rinse and dry them thoroughly. **ALWAYS wash the accessories used.**

### HOW TO CLEAN THE INNER OVEN DOOR GLASS

One of the features of our cookers is that the inner oven door glass can be easily removed for cleaning without the aid of specialized personnel. Just open the oven door and remove the support securing the glass (fig. 12).

#### ATTENTION!!

**This operation can be done also with the door fitted on appliance, but in this way, pay attention that when the glass is pull upwards, the force of the hinges can close the door roughly.**

### OVEN SEAL

The oven seal guarantees the correct functioning of the oven. We recommend you:

- clean it, avoiding abrasive tools or products.
- check its state now and then.

**If the oven door seal has become hard or is damaged, contact our Service Centre and avoid using the oven until it has been repaired.**

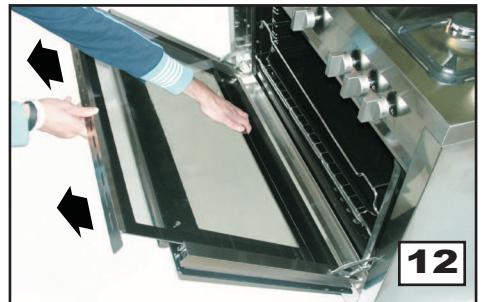
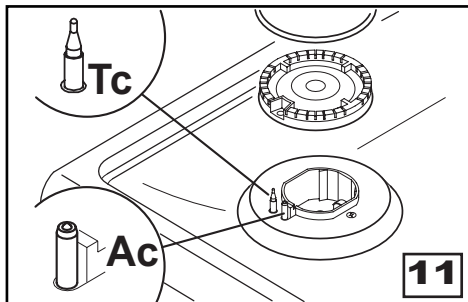



## INSTRUCTIONS FOR THE USER

### OVEN DOOR REMOVAL

The oven door can be removed to give easier access to the oven when cleaning. To remove, proceed as follows:

- Open the oven door and insert rivet or nail (R) in the hole (F) of the hinge (fig. F).
- Partially close the door, forcing it upwards at the same time to free stop tooth and hinge sector.
- Once the hinge is free, pull the door forwards tilting it slightly upwards to free sector.
- To reassemble proceed in the reverse order, paying attention to the correct position of sectors.

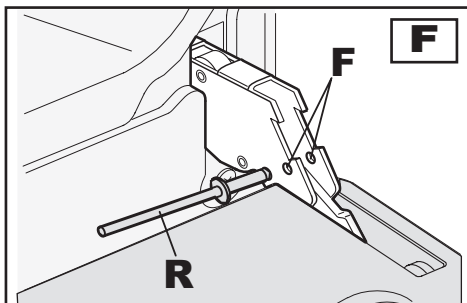

### REPLACING THE OVEN LAMP (fig. 13)

**Ensure the appliance is switched off before replacing the lamp to avoid the possibility of electric shock..**

In the event oven lamp need replacing, the new lamp must comply with the nominal data indicated on page 23 and must be resistant to high temperature (300°C).

Draw out the side guide rails as described above. Then, remove the glass protection cap (V) from the bulb socket, lifting it with a screwdriver placed between the cap and the oven wall and replace the lamp (L). Fit the accessories back in reverse order.

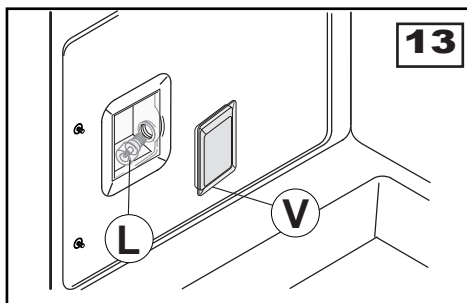

## TROUBLESHOOTING

Some problems can be caused either as the results of simple maintenance operations or by incorrect selection of settings. Prior to contacting a Service Centre please check the following chart.

PROBLEM	REMEDY
The appliance is not working	<ul style="list-style-type: none"> <li>• Make sure the gas cock is open</li> <li>• Check the plug is in</li> <li>• Check that the knobs are set correctly for cooking and then repeat the operations given in the handbook</li> <li>• Check the electrical system safety switches (RCD). If there is failure in the system call an electrician in.</li> </ul>
The electric oven is not working	<ul style="list-style-type: none"> <li>• Check that the programmer accessory, if there is one, is on the manual position and then repeat the operations described in the manual</li> </ul>
The thermostat is not working	<ul style="list-style-type: none"> <li>• Contact Service Centre..</li> </ul>
The electric thermostat warning light does not switch on during use	<ul style="list-style-type: none"> <li>• Turn the thermostat round to a hotter temperature</li> <li>• Turn the selector round to a different function</li> </ul>
The oven light does not switch on	<ul style="list-style-type: none"> <li>• Make sure the lamp is firmly screwed in place</li> <li>• Buy a lamp for high temperatures at one of our Service Centre and fit it following the instructions <b>REPLACING THE OVEN LAMP paragraph.</b></li> </ul>

**Warning: Servicing should be carried out only by authorised personnel.**



# INSTRUCTIONS FOR THE INSTALLER

## TECHNICAL INFORMATION

**The installations, conversions and maintenance operations listed in this part must only be carried out by authorised personnel. The manufacturer cannot be held responsible for any damage to persons or property resulting from an incorrect installation of the appliance.**

- The safety and automatic adjustment devices of the appliances may, during its life, only be modified by the manufacturer or duly authorised supplier.
- This appliance shall be installed only by authorised personnel and in accordance with the manufacturer's installation instructions, local gas fitting regulations, municipal building codes, electrical wiring regulations, AS 5601 - Gas Installations and any other statutory regulations.
- Failure to install the appliance correctly could invalidate any manufacturer's warranty and lead to prosecution under the above quoted regulation.
- Before installation, make sure that local distribution conditions (gas and electrical) are compatible with the appliance's adjustment. Refer to data label for gas type.
- As it is not connected to a device for the evacuation of the products of combustion, it must be installed in accordance with current regulations and used in a well ventilated location. Particular attention must be paid to the regulations on ventilation.

## VENTILATION

All rooms require an openable window or equivalent, while some rooms require a permanent vent in addition to the openable window.

Ventilation must be in accordance with AS5601 - Gas Installations. In general, the appliance should have adequate ventilation for complete combustion of gas, proper flueing and to maintain temperature of immediate surroundings within safe limits.

The use of a gas appliance results in production of heat and moisture in the room in which it is installed. Ensure that the kitchen is well ventilated; keep natural ventilation holes open or install a mechanical ventilation device (mechanical extraction hood).

Prolonged intensive use of the appliance may call for additional ventilation, for example increasing the level of mechanical ventilation where present.

## UNPACKING YOUR COOKER

- Once the packaging has been removed, thoroughly check that the appliance is in perfect condition. If you have any doubts do not use the appliance and call our Service Centre.
- Do not move the appliance by the handles.
- Some parts mounted on the appliance are protected by a plastic film. This protection must be removed before using the appliance. We recommend slitting the plastic film along the edges with a sharp knife or pin.

**The packaging materials used (cardboard, plastic bags, polystyrene foam, nails etc.) must not be left anywhere within easy reach of children as they are a potential hazard source.**

## POSITION (fig. 14)

The appliance should be positioned in good light and free from draughts. Any adjoining wall surface situated within 200 mm from the edge of any hob burner must be a suitable non-combustible material for a height of 150 mm for the entire length of the hob. Any combustible construction above the hotplate must be at least 750 mm above the top of the burner and no construction shall be within 450 mm above the top of the burner.

Where a combustible surface adjacent to the cooker is less than 200 mm from the nearest burner it may be protected by a non-combustible protective layer in accordance with AS5601. The protection must ensure the surface temperature of the combustible surface does not exceed 65° C above ambient.

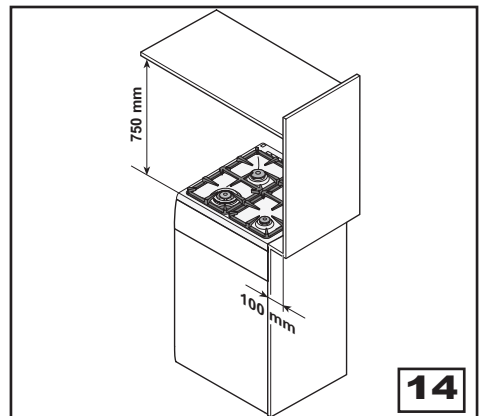

## INSTRUCTIONS FOR THE INSTALLER

### OUTSIDE COOKER DIMENSIONS (A)

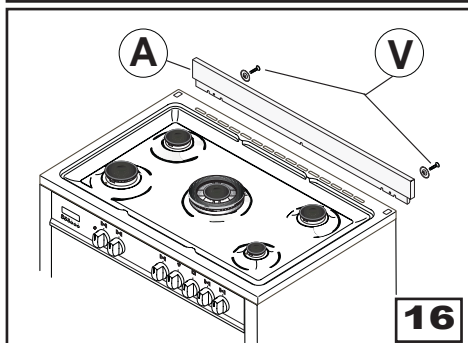
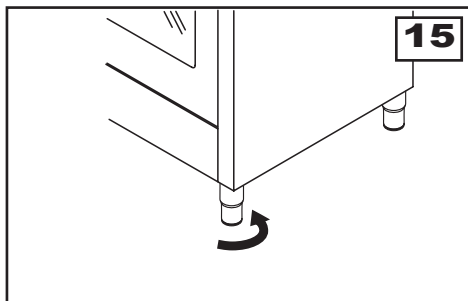
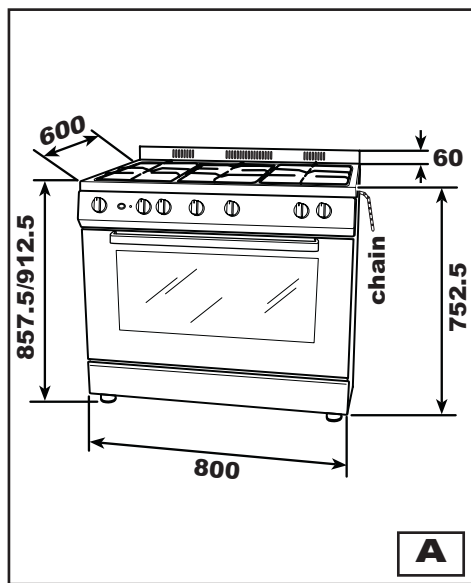

### MAINTENANCE SCHEDULE

*NO REGULAR MAINTENANCE IS REQUIRED  
EXCEPT FOR CLEANING*

### LEVELLING THE COOKER

- **Adjustable feet**, to be fitted to the appliance, which allow the height of the cooker to be aligned with other kitchen furniture. This can be done by means of the terminal part of the leg themselves (fig. 15)
- **Backguard**. The cookers which are equipped with this accessory, leave the factory with this part inserted inside the packaging. In order to install the backguard, it is necessary to loosen the screws (V) positioned on the back of the hob and then to fix the backguard as indicated in figure 16.

# INSTRUCTIONS FOR THE INSTALLER

## SECURING THE COOKER TO WALL (fig. P)

**Note:-** The installation of the chain provided is for safety reasons, it must be installed as indicated below.

To prevent the cooker tipping forwards in the event of children standing on the oven door or where users put extreme weight on the door when in open position, two chains **MUST BE** fixed to the back of the oven which should at all times be secured to the threaded pins. The threaded pins should be secured to the wall at the back of the cooker. The chains should always be attached to the upper threaded pins when the cooker is in its position against the wall. Pay attention in fact that the chain must be fixed without slack.

**WARNING: IF THE COOKER IS INSTALLED BETWEEN TWO CUPBOARDS YOU MUST DRILL A 16MM HOLE LEVEL TO THE SAFETY CHAIN HEIGHT ON EITHER CUPBOARD AS FAR BACK AS POSSIBLE, LOCATE THE COOKER INTO POSITION AND PASS THE SAFETY CHAINS THROUGH THE 16MM HOLES, WITH THE COOKER IN FINAL POSITION PULL BOTH SAFETY**

**CHAINS AND SECURE THEM TO THE INSIDE OF THE CUPBOARD WITH TWO SCREWS ON EACH SAFETY CHAIN.**

**PLEASE TEST THAT THE COOKER DOES NOT TILT FORWARD.**

### Assembly instructions

- Secure threaded pins into wall immediately behind and to the left-hand side about 770 mm from the floor.
- Secure the chain under the nut before using or cleaning etc. of the cooker (fig.P).
- **NOTE FOR INSTALLER**
- To prevent strain on the Flexible Hose assembly, a chain & hook is necessary approx. 100 mm up from the floor (not provided).
- Attach the chain to the lower hooks if the cooker is installed with a hose assembly so that there is no strain on the hose when the cooker is pulled forward for cleaning or maintenance.
- The socket or the switch must be accessible once the appliance is installed.

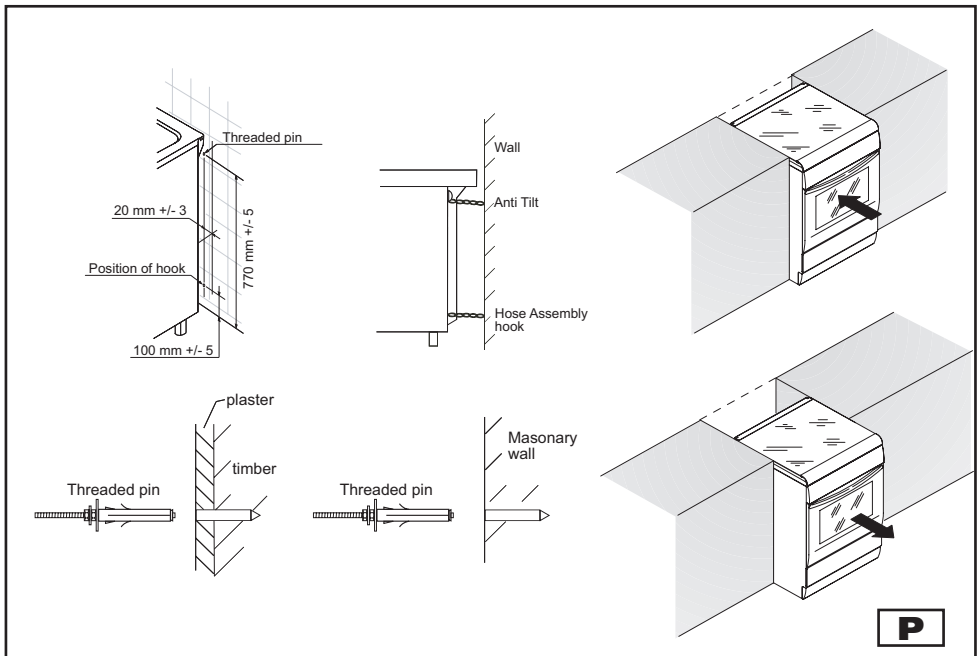

## INSTRUCTIONS FOR THE INSTALLER

### INSTRUCTION FOR STABILIZING THE COOKER

The installation of the brackets provided is for safety reasons and must be installed as indicated below.

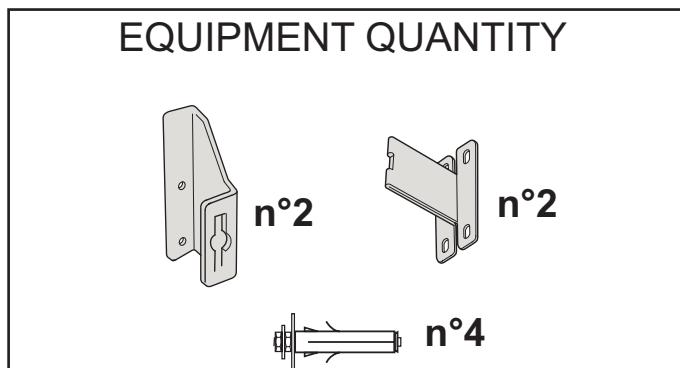

**WARNING:** In order to prevent the cooker tipping forwards in the event of children standing on the oven door or where users put extreme weight on the door when in open position, the stabilising means must be installed by the installer. Failure to fit the stabilising brackets properly may cause personal burn injuries and damage to the gas pipe.

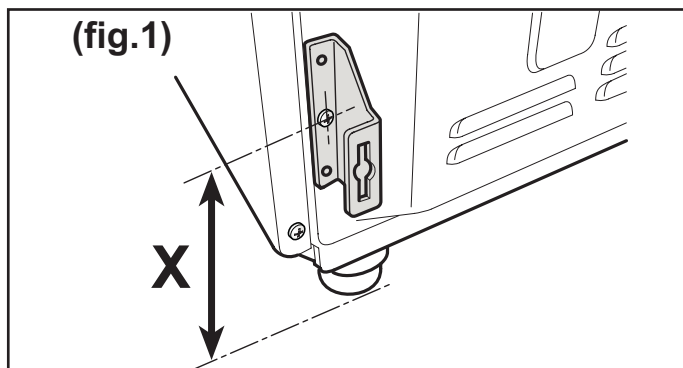

Fix the bracket on the cooker.

One for each side.

Align the cooker with the surrounding cupboard.

Measure the distance from the floor and from the fixing point of the bracket.(X)

## INSTRUCTIONS FOR THE INSTALLER

(fig.2)

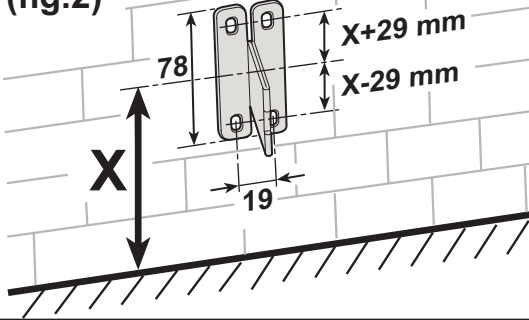

Mark it the same distance, (X) on back wall.

(fig.3)

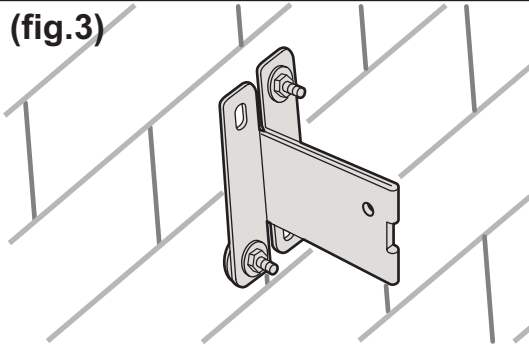

Drill two holes in the wall for each bracket according to the fig. 2 and fix the bracket.

(fig.4)

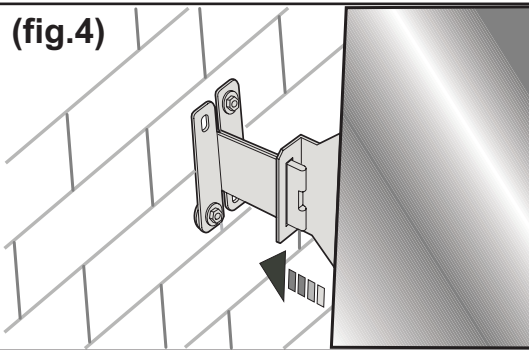

Push back the cooker against the wall.

**IMPORTANT:** After fitting the stabilising brackets and pushing the cooker into position, check that the cooker does not tilt forward or sideways

### **Hose Restraint Chain**

**The installer must fit a chain, no more than 80% of the hose length to ensure that there is no strain on the hose when the cooker is pulled forward. Attach one end of the chain as close as possible to the gas inlet on the cooker and the other end as close as possible to the gas outlet on the wall. Suitable chain and fittings are to be supplied by the installer.**

# INSTRUCTIONS FOR THE INSTALLER

## GAS CONNECTION

This appliance shall be installed only by authorised personnel and in accordance with the manufacturer's installation instructions, local gas fitting regulations, municipal building codes, water supply regulations, electrical wiring regulations, AS 5601 - Gas Installations and any other statutory regulations.

The appliance is adjusted to work at gas indicated on the label which is applied on the glass-window of the oven door and on the cooker packing.

### Installation for Natural gas

Connected regulator (B) to fitting (A) which is then fitted to elbow (F). Ensure arrow on regulator point in the direction shown. Fitting (D) to be supplied by installer (fig. 17). Adjust regulator to give test-point pressure given on data label and on page 23, with one large or one medium burner alight at maximum.

### Position of Regulator (fig. 17)

If stove is to be installed on legs, a gas pipe between fitting (A) and (B) will allow location of the regulator (B) underneath the stove for adjustment and maintenance. If stove is installed on it's base, the regulator should be fitted at rear of stove on fitting (E) for maintenance and adjustment.

**Note: When the regulator is fitted at the rear of the cooker at least 60 mm clearance is required.**

## Installation using flexible connection

As an option, the cooker may be installed with a flexible connection hose, which complies with AS/ NZS 1869 (AGA Approved), 10 mm ID, class B or D, Minimum 1000 mm - Maximum 1200 mm, as an alternative connection.

- All cookers offer left or right hand connection. The manifold has a flat flair over which is inserted a screw nut male  $\frac{1}{2}$ " gas (fig. 18).
- An isolating tap and pressure regulator must be fixed to the rear wall and the flexible pipe attached by means of a union connector.
- The gas connection and isolating tap must be accessible to a service person or inspector.
- The hose assembly must be installed in accordance with AS5601 for a high level connection. The hose should not be subjected to abrasion, kinking or permanent deformation and should be able to be inspected along its entire length. Unions compatible with the hose fittings must be used and connections tested for gas leaks. The fixed consumer piping outlet should be at approximately the same height as the cooker connection point, pointing downwards.
- The hose should be clear of the floor when the cooker is in the installed position. The anti-tilting chain supplied should be anchored to the lower hook fixed to the wall so that the chain prevents strain on the hose connections when the cooker is pulled forward.

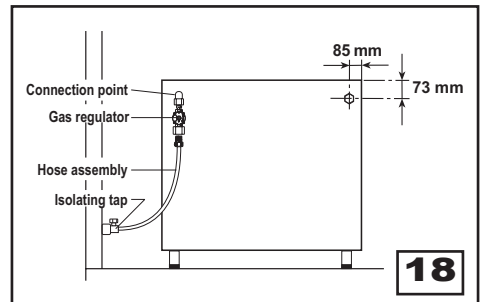
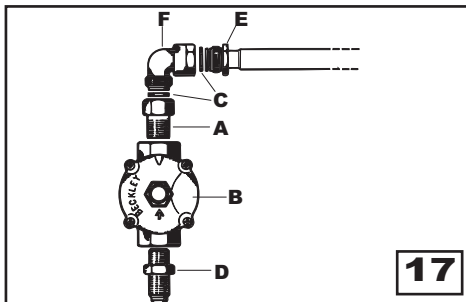

# INSTRUCTIONS FOR THE INSTALLER

## ELECTRICAL CONNECTION

The electrical connection must be carried out in accordance with the current standards and laws in force and by an authorised electrician.

- **Warning this appliance must be earthed.**
- Connection to the electricity supply must be made by an authorised electrician to a suitable isolating switch in accordance with the requirements of SAA Wiring Rules, AS/NZS 3000.
- A cable of the correct rating must be used (see Electrical components).
- Means of disconnection shall be provided in the fixed wiring in accordance with the Australian wiring rules.
- **Remember that the earth wire must be longer than the phase wires.**
- **Note:** The power supply cable must be positioned so that no part of cable can come into contact with any surface which could reach temperatures in excess of 75 K.

## ADJUSTMENTS

- **Always disconnect the appliance from the electricity supply before making any adjustment.**
- **All seals must be replaced by the technician following any adjustment or regulation.**
- **The adjustment of the reduce rate (simmer) must be undertaken only with burners functioning on natural gas while in the case of burners functioning on Propane, the screw must be locked down fully (in clockwise direction).**
- **“Primary air adjustment” on hob gas burners is unnecessary.**
- **If the appliance cannot be adjusted to perform correctly refer to the authorised service provider in your area.**

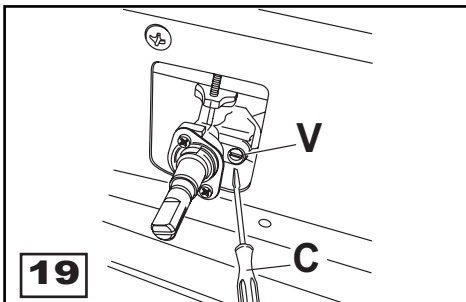

## TAPS (fig. 19)

All gas taps are male cone type with only one way of passage. The adjustment screw (V) is on the side of the stem.

Adjustment of the “**Reduced rate**” position as follows:

- Turn the burner on and place the knob on the “Reduced rate” position (small flame).
- Remove the knob of the tap which is attached by simply applying pressure to the rod.
- With a small screwdriver (C) turn to the right or left the adjustment screw (V) until the flame of the burner is conveniently regulated to the Low position.
- Check that the flame does not go out when the knob is sharply switched from the “Full on” to “Reduced rate” positions.

## OVEN THERMOSTAT (fig. 19A)

**Reduced rate adjustment** should be carried out in the following way:

- Remove the knob thermostat.
- Switch on the oven burner by turning the relative knob to the Maximum position, then wait about 10 minutes.
- Slowly turn the knob back to the Minimum position and, using a small screwdriver (C), turn screw (V) to the right to lower the flame or to the left to increase it.

The flames must be short for an efficient Reduced rate setting. They must be stable to prevent them from accidentally going out and must be able to stand up to normal oven door manoeuvres.

## NOTE:

### Oven Failure

- Check thermocouple terminal.
- Inspect rear of thermostat (under hob) to check that thermocouple connections are “tight” and parallel to each other.
- Check thermostat knob for sufficient clearance from the control panel to allow electromagnet to fully seat. • If above cannot solve the problem, replace thermocouple.

### Oven Ignition Failure

- Ensure that the electrode lead is not “earthing” against cabinet.
- Check spark gap from electrode tip to burner. Should be only 5-6 mm.
- Check ceramic body of electrode for obvious damage or cracks.
- If no spark at all, check ignition box failure or power source.

# INSTRUCTIONS FOR THE INSTALLER

## Hot Plate Ignition Failure

- Check alignment of burner holes to electrode.
- Check aeration sleeve for adjustment for gas type, location and ambient conditions.
- No spark, check ignition box failure or power supply.

## Before Leaving

- Check all connections for gas leaks with soap and water. **DO NOT** use a naked flame for detecting leaks. Ignite all burners to ensure correct operation of gas valves, burners and ignition.
- Turn gas taps to low flame position and observe stability of the flame. When satisfied with the cooker, please instruct the user on the correct method of operation.
- In case the appliance fails to operate correctly after all checks have been carried out, refer to the authorised service provider in your area.

## OVEN BURNER (fig. 20)

The burner is installed on the oven base and is covered by the bottom plate which must always remain in that position during oven operation,

To adjust the primary air, is performed when the burner is ignited, by adjusting the sleeve (B) and unscrewing screw (A). Lock screw (A) in place once the adjustments have been made.

## CHANGING THE FLEXIBLE GAS HOSE

In order to guarantee that the gas hose is always in excellent condition we strongly recommend changing it on the date you will find printed on it.

## GAS CONVERSIONS

### REPLACING THE INJECTORS

Our burners can be adapted to different types of gas by simply installing the injectors suitable for the gas you want to use. To help the installer, the table on page 23 gives the burner nominal heat input, injector diameter and operating pressure of the different gas types.

Comply with the following instructions:

### Injector replacement - Hob burners.

To change the injectors on the hob, remove the burner cup and head and with a 7 mm Ø socket spanner replace them (fig. 21).

### Injector replacement - Oven burner.

Remove oven base. Remove screw (D) (fig. 20) which will release burner and give access to the injector (C). Unscrew injector and replace it. Replace burner and replace screw (D).

**After having replaced the injectors, it will be necessary to proceed with burner adjustment as explained in the previous paragraphs.**

## REPLACING THE ELECTRICAL COMPONENT

- The rear protection will have to be removed in order to change the electrical heating elements, spit motor, terminal board and power cable.
- If you have to change the power cable (see TECHNICAL FEATURES paragraph), always keep the earth wire longer than the phase wires and, in addition, follow all the instructions given in the "ELECTRICAL CONNECTION" paragraph.
- To change the oven lamp see the instructions REPLACING THE OVEN LAMP paragraph.
- To change the lamp holder, the spark generator and the spark electrodes, the work top has to be removed as indicated in the paragraph «REPLACING THE TAPS».
- To change the programming accessory, the thermostat, the commutator and the warning lights, remove the front panel by unscrewing the three fixing screws which lock it to the front frame.

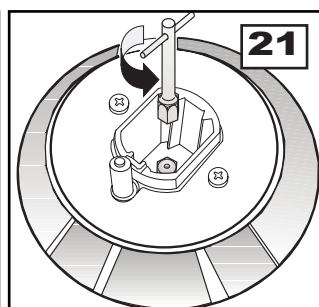
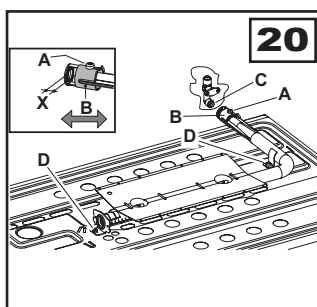
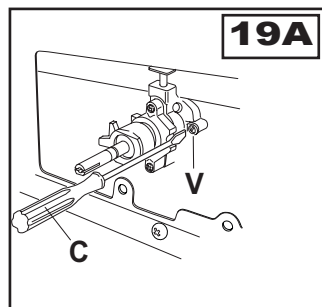



# INSTRUCTIONS FOR THE INSTALLER

## MAINTENANCE

Prior to any maintenance work or changing parts, disconnect the appliance from the gas and electricity power sources. Servicing must only be carried out by authorised personnel.

### REPLACING THE TAPS AND THERMOSTAT

Proceed in the following way when replacing a tap or thermostat :

- Remove pan supports, burner heads.
  - Unscrew the burner fixing screws (Vc) (fig. 24). (four for ultrarapid burner and two for the other burners)
  - Remove the hob, unscrewing frontal and rear fixing screws (Vs) (fig. 24) which lock the hob at the supports (S).
  - Pull out the knobs.
  - Unscrew the nuts (D) of the gas aluminium pipes and pull out the thermocouple quick connectors (F) (fig. 23).
  - Unscrew the screws (Vt) (fig. 22) which lock the crosspieces.
  - Unscrew the screws (Vb) (fig. 22) which unite the the bridles of the taps to the front frame.
  - Make to slip the ramp toward the back part and unscrew the screws (Vb) (fig. 23) in order to free the taps.
  - Change seal each time a tap or a thermostat is replaced. This will ensure perfect retention between the tap or a thermostat and part.
- Reassemble all the parts following the same procedure but in the reverse order.

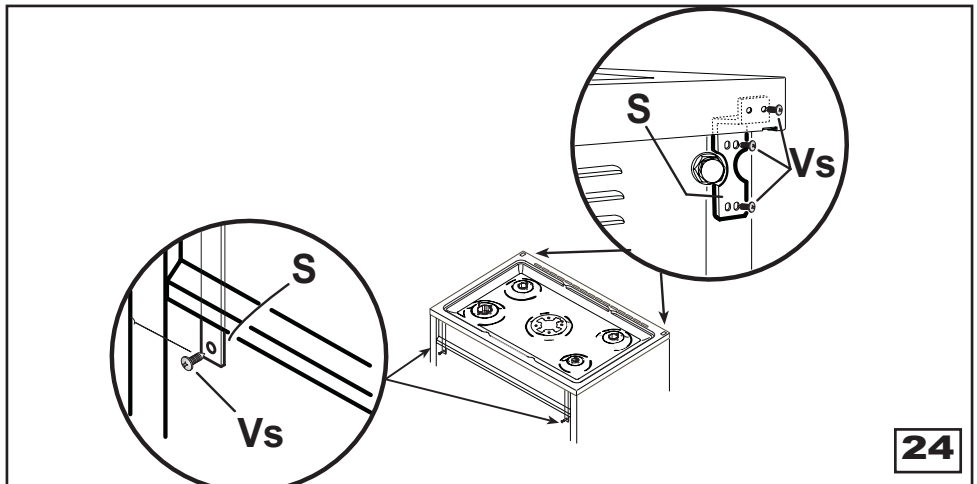
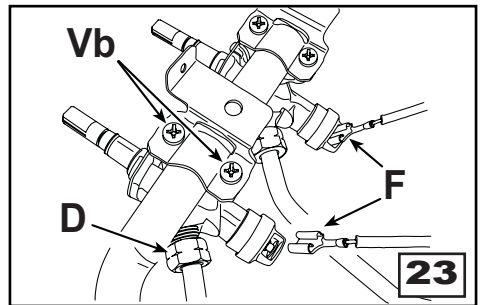
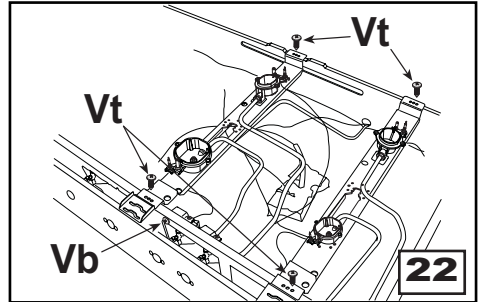

## TECHNICAL FEATURES

### BURNER DISPOSITION

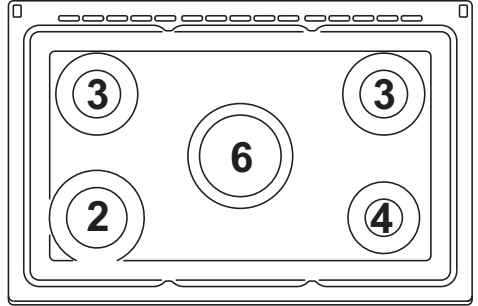

### BURNER TECHNICAL DATA TABLE

N.	BURNER DENOMINATION	GAS	Operating Pressure kPa	Diameter Injectors 1/100 mm	Primary aeration	Rating MJ/h
2	Large Left front	Propane	2.75	88		10.0
		Natural	1.00	142		10.0
3	Medium Right rear	Propane	2.75	73		7.2
		Natural	1.00	120		7.2
3	Medium Left rear	Propane	2.75	73		7.2
		Natural	1.00	120		7.2
4	Small Right front	Propane	2.75	54		3.8
		Natural	1.00	90		4.0
6	Wok Center	Propane	2.75	105		14.6
		Natural	1.00	175		15.0
7	Oven	Propane	2.75	108	7.5 mm open	15.1
		Natural	1.00	180	7.5 mm open	15.1
8	Grill	Propane	2.75	92	7.5 mm open	11.0
		Natural	1.00	155	7.5 mm open	11.0

### ELECTRICAL COMPONENTS NOMINAL DATA

DESCRIPTION	EG800FS2 - ESG800GUSX
Oven lamp	15 W - E 14 - T 300
Fan of the rear heating element	25..29 W
Cooling fan	12 W
Power cable	H05 RR-F 3 x1 mm <sup>2</sup>
Voltage / Frequency	240 V~ / 50 Hz
Total rating electric	40 W

### TECHNICAL DATA

GAS	NATURAL	PROPANE
Operating pressure gas	1.00 kPa	2.75 kPa
Total input gas	58.5	57.9

# TECHNICAL FEATURES

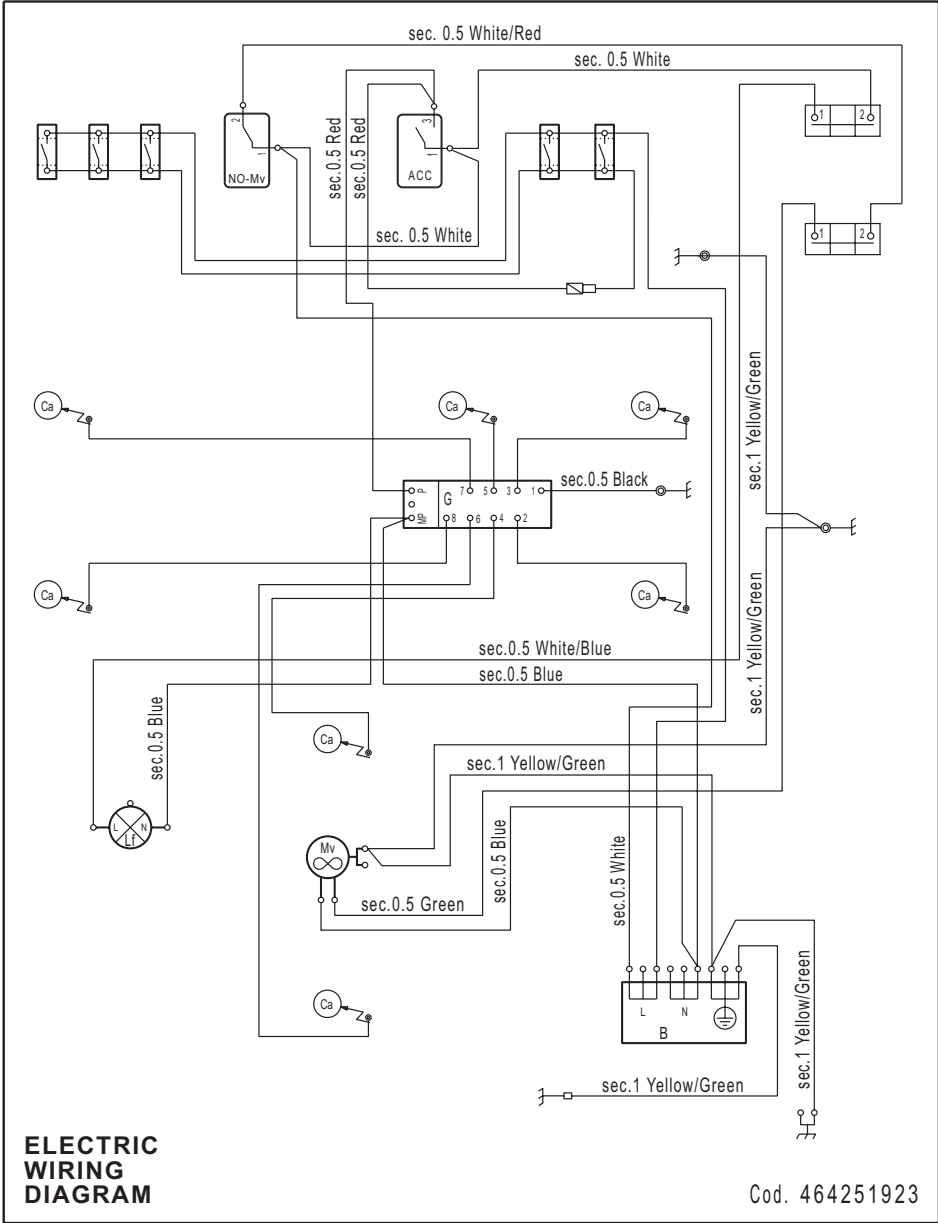

**ELECTRIC  
WIRING  
DIAGRAM**

Cod. 464251923

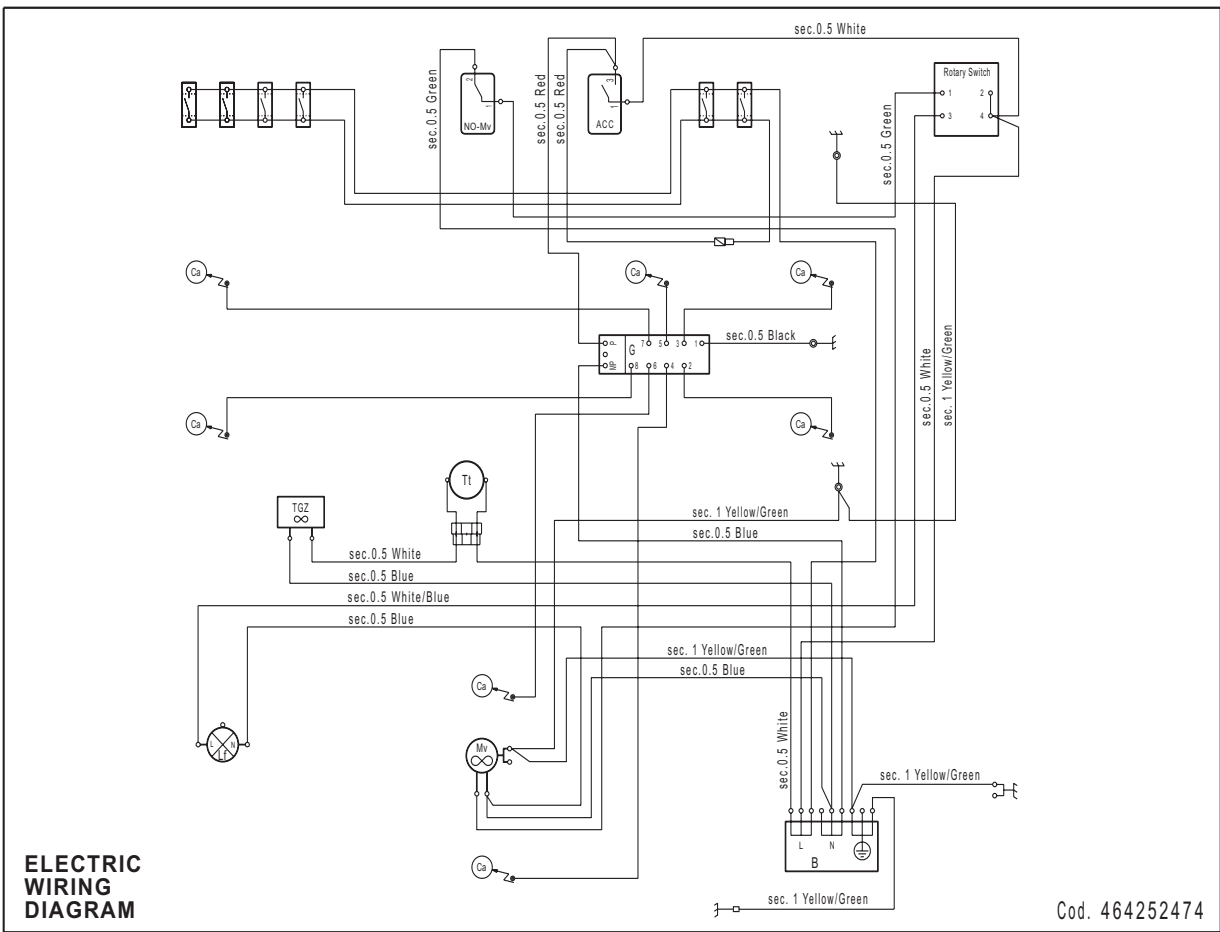

ELECTRIC WIRING DIAGRAM

Cod. 464252474







**SPACE FOR DATA LABEL**