

omega

Instruction Manual for Cooktop OCI60MZ

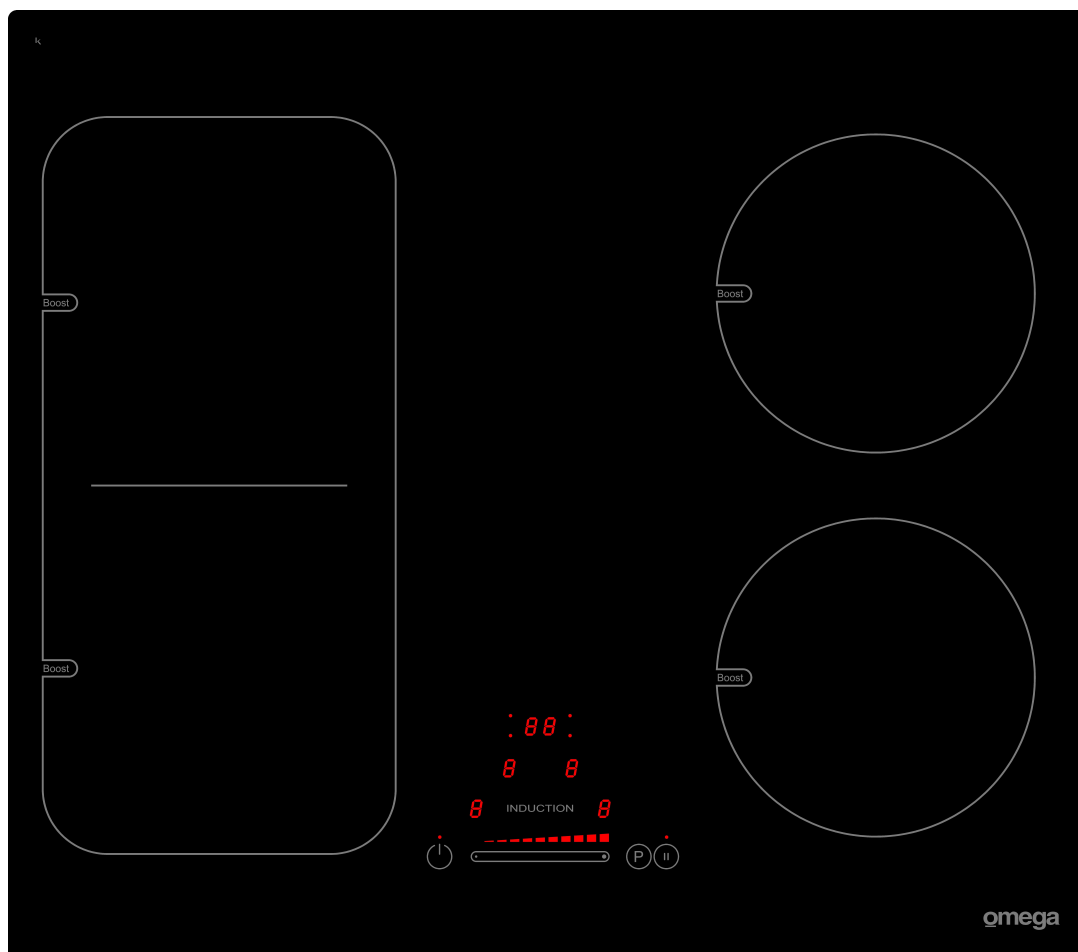

Thank you for introducing our family to yours

At Omega, we understand that cooking, cleaning and washing may not be your favourite things in the world. That's why we created a range of no-nonsense, reliable products that always get the job done for you. With the features you need and nothing you don't. What's more, they're made to fit perfectly into your home life and your wallet. You are welcoming an Omega appliance into your place and you can be sure it'll always serve you well.

We aim to simplify any further appliance purchases. When researching our products you will find a range of icons that visually represent our products key features. Visit our website to learn more about these icons and the features and benefits of our products.

For warranty, instruction manuals, specifications and catalogues, please click the "Support" tab of our website omegaappliances.com.au.

We value your opinion, so please take a few minutes to tell us what you think about your new addition! Simply go to the relevant appliance page of our website and click on "Write a Review".

If you want to know more about promotions, receive cool tips and participate in our giveaway challenges, simply connect with us on social media; like [omegaappliances](https://www.facebook.com/omegaappliances) on Facebook and follow [omegaappliances_au](https://www.instagram.com/omegaappliances_au) on Instagram.

Enjoy your new appliance and remember, we're only one click away!



omegaappliances.com.au



[omegaappliances](https://www.facebook.com/omegaappliances)



[omegaappliances_au](https://www.instagram.com/omegaappliances_au)

omega. Always serves you well.

TABLE OF CONTENTS

SECTION	PAGE NO.
Important Safety Instructions.....	1-2
Cooktop Details	2
Installation	3-4
Operating Instructions	5-10
Cleaning	11
Electrical Connections	12
Trouble Shooting and Error Codes.....	13-14
Warranty	15

IMPORTANT SAFETY INSTRUCTIONS

IMPORTANT: Read the assembly instruction section and safety precautions of this booklet carefully before removing the contents of this carton.

- 1. This Cooktop is not intended for use by persons (including children) with reduced physical, sensory or mental capabilities, or lack of experience or knowledge, unless they have been given supervision or instruction concerning the use of the Cooktop by a person responsible for their safety. Children should be supervised to insure that they do not play with the Cooktop.**
- 2. After removing the packaging, make sure to check if there is any damage to the Cooktop. If there is any damage, never attempt to use the Cooktop and immediately contact your Authorised Service Centre. As packaging materials can be dangerous to children, they need to be collected immediately and put out of reach.**
- 3. In certain circumstances electrical appliances may be a safety hazard. Check the conformity of voltage and power settings, which are specified on the information plate attached to the Cooktop and/or packaging, with the usage conditions available.**
- 4. Do not place heavy objects in or on these appliances, use for storage or as a cutting surface as sharp edges can damage the surface. This Cooktop is designed for cooking food only. Use flat based, stable, inductive cooking rated Cookware only.**
- 5. This Cooktop is designed for domestic household use only and for the cooking of domestic food products. Use as a commercial Cooktop will void the warranty. It should not to be used in a marine environment or outdoors and must be fully built in. Do not use the appliances until fully installed.**
- 6. A means for disconnection must be incorporated in the fixed wiring in accordance with the wiring rules.**
- 7. The electrical connection must be accessible after installation. The Cooktop must be electrically isolated before any maintenance can be performed.**
- 8. The Cooktop is not intended to be operated by means of an external timer or separate remote control system.**
- 9. Electrical connection must be made as per local wiring rules and regulations. Do not disconnect the Cooktop with wet hands or bare feet, and do not disconnect the power cord with extreme force.**
- 10. Ensure that the kitchen is well ventilated or mechanical ventilation is in use while cooking on this Cooktop.**
- 11. Do not store or use flammable materials or aerosols near the cooktop. Items made from aluminium, plastic, plastic film & sugar based foods should also be kept away from the Cooktop, as they may fuse to the surface.**
- 12. Heat from the underside of the unit will be expelled by inbuilt fans – do not block. It is essential that the installation instructions relating to ventilation are followed, otherwise the Cooktop can fail.**
- 13. WARNING - The cooktop will become hot during and directly after use. Do not touch the surface during this time, as it may be hot and can cause burns. To avoid burns, children should be kept away.**
- 14. Cleaning may only be commenced on the Cooktop once it has cooled down and is turned off. Failure to clean properly can damage the unit. Do not use a steam jet or any other high pressure cleaning equipment to clean the Cooktop.**
- 15. When the Cooktop is not being used, turn the Cooktop off. Do not cover with any type of protection sheet or cloth, as these may ignite and burn.**
- 16. Where this Cooktop is installed in a caravan, it shall NOT be used as a spaceheater.**
- 17. Do not modify this Cooktop. Remove all labels from the glass cooktop before operating.**
- 18. Do not use harsh abrasive cleaners or sharp metal scrapers to clean the glass surface as they can scratch the surface, which may result in the glass shattering. Clean the glass using a warm damp cloth (e.g. dishcloth) and dry it with a soft dry teatowel.**
- 19. Do not install this Cooktop above a dishwasher or clothes dryer, as the steam may damage the internal circuitry.**
- 20. If any cracking or chipping is noticed on the cooktop, turn the Cooktop off immediately and call your Authorised Service Centre.**

21. All cabinetry and materials used in the installation must be able to withstand a minimum temperature of 100°C above ambient temperature whilst in use. Certain types of vinyl or laminate kitchen furniture are particularly prone to heat damage or discolouration at temperatures below the guidelines given above. Any damage caused by the Cooktop being installed without adhering to the temperature limits set out above will be the liability of the owner. To avoid any hazards, limit access to the under-bench section of the cook top.
22. The Cooktop must be installed and put into operation by an authorised person under the conditions provided by the manufacturer in this manual. The manufacturer cannot be held responsible for any damage that might occur due to faulty installation.
23. Damage can occur to bench tops if pots and pans are allowed to overlap the bench top. This can result in heat being transferred to the bench top. Ensure that correct sized pots & pans are used. Pans should be lifted on and off the cooktop surface and not dragged. Cooking zones should not be switched on without cookware placed on it. Do not place empty cookware onto the cooking zones when in use.
24. Do not leave the cooktop unattended while cooking with solid or liquid oils. There may be flaming up in conditions of extreme heating. Never pour water onto the flames occurring from oil. Immediately turn the cooktop off and cover the pan with a lid or fire blanket in order to smother the flame.
25. Users with pacemakers should keep their upper body at least 30cm away from any operational inductive cooking zone. If in doubt, please consult your doctor before use.
26. Do not place metal objects such as spoons or pan lids onto the cooktop as they may become hot or cause damage to the surface.
27. A small amount of noise will sometimes be heard as elements turn on & off during operation. This is normal & not a fault. The sound of the fans will vary depending on cooking zone usage.



DO NOT
DO NOT
DO NOT

OPERATE THIS COOKTOP BEFORE READING THE INSTRUCTION BOOKLET
PLACE ARTICLES ON OR AGAINST THIS COOKTOP
STORE CHEMICALS OR FLAMMABLE MATERIALS OR SPRAY AEROSOLS NEAR THIS COOKTOP

COOKTOP DETAILS

ELECTRICAL DETAILS:

COOKTOPS:

Rated Voltage: Single phase 220-240Vac 50Hz, 2-phase 380-415Vac 50Hz: 7400W.
This information can be found on the rating plate (identification plate) affixed to the underside of the Cooktop.

Type	Total Power	Position of the heating zone	Nominal Power*	Booster Power*	Diameter	Minimum diameter detection
Induction	7400 W	Front left	1400 W	1850 W	175mm	100mm
		Rear left	1400 W	1850 W	175mm	100mm
		Front right	1400 W	1850 W	175mm	100mm
		Rear right	1400 W	1850 W	175mm	100mm

* The given power may change according to the dimensions and material of the pan. Nominal power on cooking zones may adjust lower when the boost function is being used on other cooking zones, to keep the Cooktop from exceeding the rated total power.

COOKTOP – Directly wired to mains supply.

SIZES:

Relevant Sizes:	LENGTH (mm)	WIDTH (mm)	HEIGHT (mm)
Cooktop Size (OCI60MZ)	590	520	58
Cut-out Size (OCI60MZ)	560	490	-

INSTALLATION



The adjacent furniture must be able to withstand a minimum temperature rise of 100°C above the ambient temperature of the room it is located in, during periods of use. The power supply to the Cooktop must be cut off before any adjustments or maintenance work is done on it. The Cooktop must be well ventilated (as per this manual) otherwise the Cooktop will overheat.

PREPARATION FOR INSTALLATION AND USE

Manufactured with best quality parts and materials, this modern, functional and practical cooktop will meet your needs in all respects. Make sure to read the manual to obtain successful results so as not to experience any problems in the future. The information given below contains rules that are necessary for correct positioning and service operations. They should be read without fail, especially by the technician who will position the Cooktop.

CHOOSING A LOCATION FOR THE COOKTOP

There are several points to pay attention to when choosing a location for your cooktop. Make sure to take into account our recommendations below in order to prevent any problems and dangerous situations, which might occur later!

When choosing a location for the cooktop, attention should be paid that there are no flammable or combustible materials in the close vicinity, such as curtains, oil, cloth etc. which quickly catch fire.

Ensure a distance between the cooktop edge and rear or side walls of at least 50mm. Furniture surrounding the cooktop must be made of materials resistant to temperatures above 100 C°. Required changes to wall cabinets and exhaust fans above a built-in cooktop as well as minimum heights from the oven board are shown in Figure 1. Accordingly, the exhaust fan should be at a minimum height of 65 cm from the cooktop. If there is no exhaust fan the height should not be less than 70 cm.

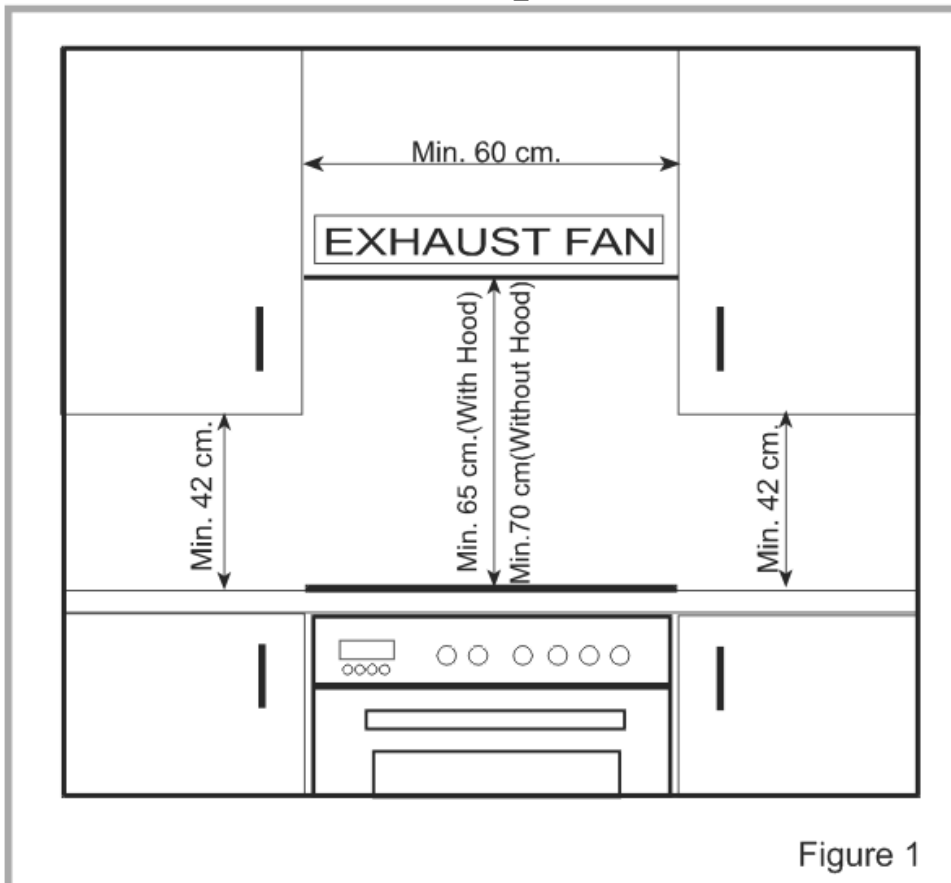
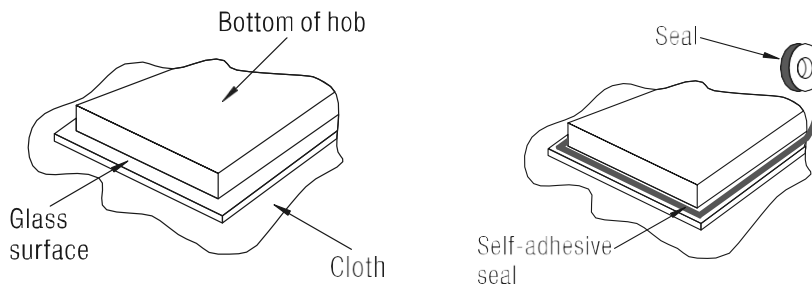

Figure 1

INSTALLATION OF BUILT IN COOKTOP

In order to prevent leakage of any liquids on the work bench and fix the Cooktop to the bench, a special sealing tape is supplied together with your oven. Place the cooktop glass down on a clean cloth on a stable flat surface & apply this seal around the bottom edge of the cooktop (see below). Remove the backing from the sealing tape and then place the Cooktop in position. If the sealing tape is not enough to fully seal the Cooktop to the bench, use a small bead of clear high temperature resistant silicone sealant.



This Cooktop can be installed into a workbench 30-40mm thick. When cutting the hole in the work bench, keep in mind the correct space and ventilation which are shown in the diagrams below.

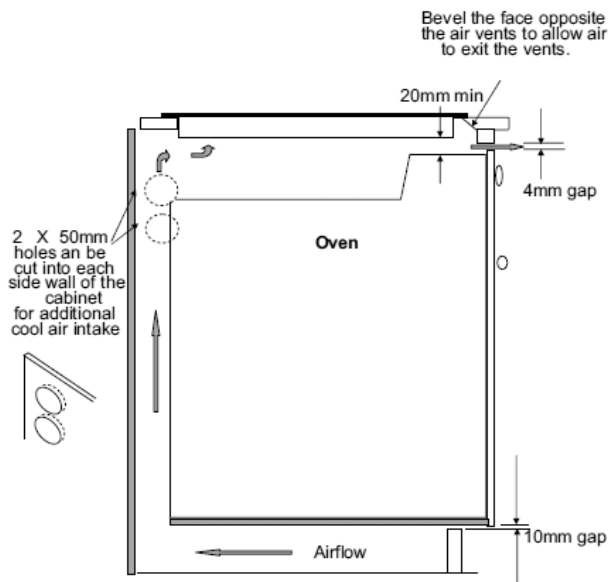

Minimum clearances and ventilation requirements for cooktops installed above an oven

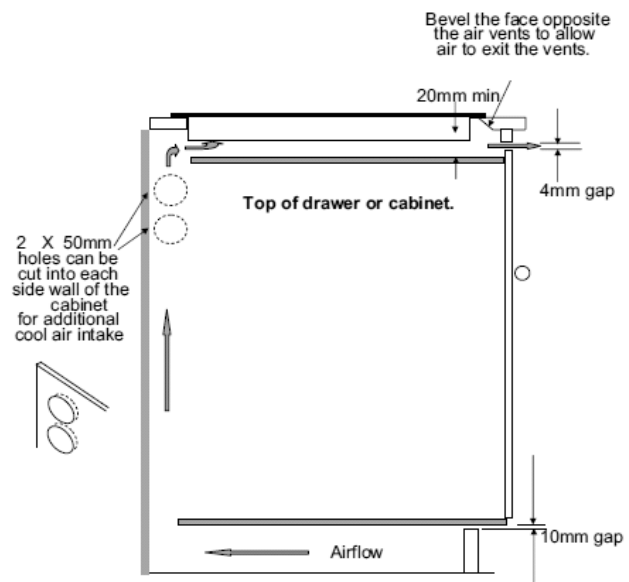

Minimum clearances and ventilation requirements for cooktops installed above a cabinet or drawers

A board must be placed a minimum of 20mm below the cooktop that prevents anyone from touching the underside of the cooktop. Take care that there is adequate ventilation for air exchange to the inductive elements (at least 20mm).

NOTE: INDUCTIVE COOKTOPS GENERATE A LOT OF HEAT INTERNALLY WHEN IN OPERATION. THE BOTTOM OF THE COOKTOP MUST HAVE A CLEAR PATHWAY TO VENT THIS HEAT OUT VIA THE BOTTOM FANS TO THE OPEN AIR IN ORDER TO KEEP ITSELF COOL. FAILING TO PROVIDE ADEQUATE VENTILLATION WILL DAMAGE THE COOKTOP AND VOID YOUR WARRANTY. THE ABOVE DIMENSIONS SHOULD BE CONSIDERED THE MINIMUM VENTILLATION REQUIRED.

OPERATING INSTRUCTIONS

The basic layout of the induction cooktop is shown in the diagrams below.

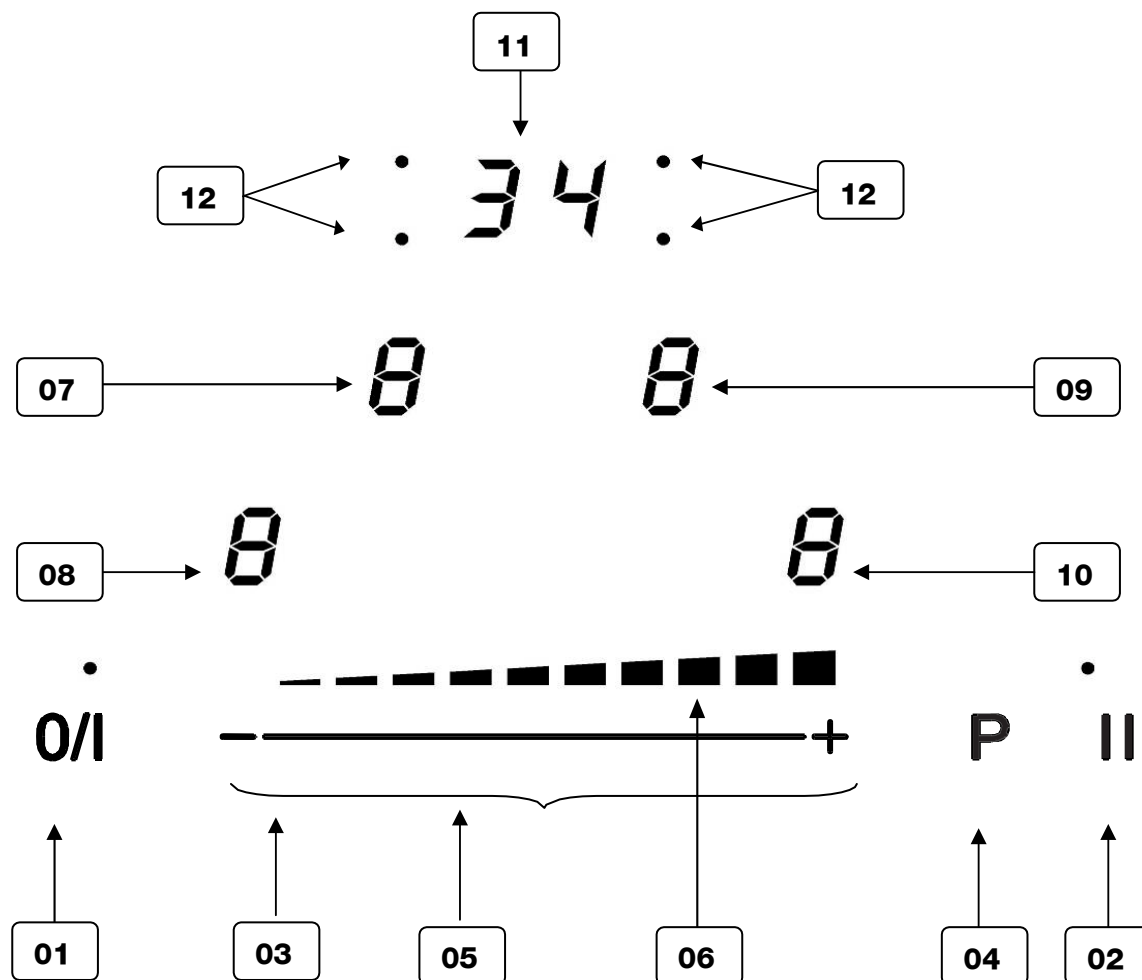

	DESCRIPTION		DESCRIPTION
01	On/off Power touch control	07	Cooking Zone Select touch control & Power LED display (LHR)
02	Stop N Go/Recall Function touch control	08	Cooking Zone Select touch control & Power LED display (LHF)
03	Keep Warm Function touch control	09	Cooking Zone Select touch control & Power LED display (RHR)
04	Boost Power touch control	10	Cooking Zone Select touch control & Power LED display (RHF)
05	Power/Timer Slide touch control	11	Timer Touch Control & LED display
06	Power/Timer Slide LED Indicator	12	Cooking Zone Timer Select Indicator

The induction Cooktop is operated by touching the control buttons, with the functions confirmed by LED displays and acoustic signals. Clean glass surface with a damp cloth and dry before use.

Note: All cooking zones have a pre-set limit on the length of time they will run without any setting changes (table further in the manual).

Turning On and Turning Off the Cooktop

NOTE: Do not operate the Cooktop without first placing a suitably sized cookware on the appropriate cooking zone. If the correct sized cookware is not placed on the cooking zone, the Cooking Zone Select touch control & Power LED display will indicate pan not detected. Settings can be changed, but the zone will not work until the pot is replaced.

If the Cooktop is in Stand-By-Mode, it is put into Operating-Mode by pressing the On/Off Power touch control for at least 1 second. A beep signal indicates the successful operation acoustically, with a small indicator above the touch control being lit.

Each Cooking Zone Select touch control & Power LED display will display a '0'. The decimal points on the Cooking Zone Power Displays will flash until a cooking zone is selected.

- If there is no operation within 20 seconds, all the Cooking Zone Select touch control & Power LED displays will automatically turn off and the Cooktop will be re-set into Stand-By-Mode .
- If the On/Off Power touch control is pressed for more than 1 second (in Operating-Mode), the Cooktop is switched off and is set into the Stand-By-Mode again. The Cooktop can be turned off by pressing On/Off at any time. The small indicator above the touch control will also turn off.
- If there is any residual heat remaining in a cooking zone, this will be indicated in the corresponding Cooking Zone Select touch control & Power LED display as a red "H" .

Selecting A Cooking Zone

1. Select a single cooking zone by pressing the corresponding Cooking Zone Select touch control & Power LED display (07, 08, 09 or 10), and the decimal point of the chosen cooking zone stays bright while the others turn off.
2. For the selected cooking zone, you can set or adjust the power level between 1-9 by touching the Power/Timer Slide touch control (05) All of the other cooking zone displays will have a visible '0', value (if in use) or 'H' (if recently used). The Power/Timer Slide touch control can be operated by either touching the sensor at some point (lower values to the left), or placing a finger on the sensor and sliding it left and right. The position will be displayed on the Power/Timer Slide LED Indicator above, as well as on the Cooking Zone Select touch control & Power LED display.

If left idle for more than 10 seconds, the LED for the chosen cooking zone display will turn off (the cooking zone is no longer selected). Press the Cooking Zone Select touch control & Power LED display again to select the cooking zone again. Other cooking zones can be selected without waiting for the previous one to become inactive.

The Cooking Zone Select touch control & Power LED display works on a thermostat system. This means that the cooking zone will switch on and off in order to remain at the chosen Power Level.

NOTE the cooking zone will remain on for longer periods if a higher Power Level is chosen, alternatively the cooking zone will be on less regularly on lower Power Level Settings.

Turning Off Individual Cooking Zones

A cooking zone can be turned off by selecting the specific cooking zone touching the Cooking Zone Select touch control & Power LED display and then using the Power/Timer Slide touch control to set the power to 0.

The Boost Function The Boost function is available to all cooking zones. It is used to speed up the initial heat up time (boil a pot of water) and only runs for a short time (5 minutes).

1. Select a cooking zone and press the Boost Power touch control (04) once, so the Cooking Zone Select touch control & Power LED display changes from the current value to "P". The power boost function is now active (indicator above the sensor is lit). Once the 5 minutes has passed, the cooking zone power level will drop to 9.

Note: The Boost function uses significantly more power than the nominal power (see Cooktop details). If used in conjunction with other cooking zones, the max power available on the other cooking zones may be reduced to keep power usage within the total allowed.

2. To disable the Boost function, press the Cooking Zone Select touch control & Power LED display for the cooking zone again (so the decimal point is on) and either press the Boost Power touch control (04) again (the cooking zone power level reverts to 9) or adjust the power level with the Power/Timer Slide touch control (05). The indicator above the Boost Power touch control will turn off (unless the second zone is using the boost function).

Activating The Key Lock

The key lock is used to set the cooktop up so that it cannot be operated without disabling the lock. This is a useful feature when cleaning down the glass, or to stop children playing with the controls.

1. Put into Operating-Mode by pressing the On/Off touch control for at least 1 second.
2. When the LED displays light up, simultaneously press the Boost Power touch control (04) and Cooking Zone Select touch control & Power LED display (RHF) (10) within 10 seconds (a beep will sound, but no change will take place with the LED displays if successful). Note: if any other control button is pressed before this, the operation must be restarted.
3. Within 5 seconds, press the Cooking Zone Select touch control & Power LED display (RHF) again. The LED displays (07, 08, 09 and 10) will change to "L". The controls are now locked and no operation except turning the Cooktop from Stand-By-Mode to Operating-Mode and back is available.
4. To unlock the control panel, repeat the sequence above, but instead of pressing the Cooking Zone Select touch control & Power LED display (RHF) at the end of the sequence, press the Boost Power touch control. When successful, all displays will turn off and a beep will sound. The Cooktop is now ready to put into Operating-Mode.

Minute Minder Function

The Minute Minder function is a timer that does not affect any operation on the Cooktop, but can be used as a reminder to take action (add a spice, turn meat etc).

1. The Cooktop must be set to Operating-Mode, so that the Timer Touch Control & LED display shows "CL".
2. Press the Timer Touch Control & LED display (11) and the LED will show "0-".
3. Within 10 seconds, adjust the minutes value (0-9) using the Power/Timer Slide touch control (05). The value will flash for 3 seconds and then the first digit will change to "-".
4. Adjust this (10 minute value) in the same way. The value will flash for 3 seconds and then the Cooking Zone Select touch control & Power LED displays will turn off, leaving the minute minder value and the indicator above the On/Off Power touch control on.
5. When the set time has passed, the Cooktop starts to beep, and the LED displays at the top of the control panel (11) will flash "00". Press any button to turn the sound off and return the Cooktop to display its operations as before.
 - The Minute Minder time can be adjusted at any point by activating the function and adjusting as above. To disable the function, adjust the time to "00". Alternatively, if no cooking zone is being used, press the On/Off Power touch control twice.

The cooktop can be used as normal during the Minute Minder operation, but setting any cooking zone Timer function will clear the Minute Minder function.

Timer Function

The timer function differs from the Minute Minder function in that it will turn off a cooking zone at the end of the time. It can be set for one or more cooking zones (each working independently). The Cooking Zone Select touch control & Power LED display always shows the shortest timer when in operation.

1. First set up the Cooktop with cookware placed on cooking zones and set all power levels.
2. Activate a cooking zone pressing its Cooking Zone Select touch control & Power LED display and within 10 seconds press the Timer Touch Control & LED display (11). The LED shows the current timer value (00 if new).
3. Set the time in the same manner as for the Minute Minder (the difference to setting the Minute Minder function time is that the decimal point of the display (12) for the selected cooking zone is also flashing). The timer starts as the last button is pressed. 3-10 seconds after the last button is pressed, the decimal point on the Cooking Zone Timer Select Indicator (12) will stop flashing and stay on as long as the timer is working. Another timer function can now be set on a different cooking zone, or power levels can be adjusted.
4. If a change needs to be made to a timer, the above can be repeated. Changing the value to "00" will disable the timer on the selected cooking zone (but not the power level).
5. When a timer function finishes, the Cooktop will start to beep indicating the cooking zone has finished. The Cooking Zone Timer Select Indicator (12) for the cooking zone will flash and the Timer Touch Control & LED display (11) LED will flash "00" for 2 minutes (unless a button is pressed) and then the displays will return to normal. Any other timer functions that are running will continue (Cooking Zone Timer Select Indicator decimal points on) until the next timer is finished. If all timer functions finish and there are no other cooking zones active, the Cooktop will return to the Stand-By-Mode after the alarm finishes.

Auto Cooking Function

The Auto Cooking Function allows you to set any or all cooking zones up so that they run at a high power level for a period of time, and then drop the power down to a lower level.

1. The Cooktop must be in set to Operating-Mode and the cooking zone selected.
2. Use the Power/Timer Slide touch control (05) to set the power to "9".
3. Let go of the sensor and then press (+) again (the Cooking Zone Select touch control & Power LED display changes to "A"). Holding down the sensor, slid the sensor back to the left to set a low power setting. After 5 seconds, the Select touch control & Power LED display will alternate between "A" and the low power setting. At this point, the cooking zone will run for a set time at high, and then drop down to the low power setting (at which point the Cooking Zone Select touch control & Power LED display changes to the low power setting). See table for times on next page.
4. To disable the Auto Cooking Function, select the cooking zone and pick a new power setting.

Bridge Function

The Bridge Function allows you to join the two cooking zones on the left hand side of the cooktop.

1. Turn on the cooktop using the On/Off touch control.
2. Press and hold both Cooking Zone select touch controls for the left hand side cooking zones.
3. The bridge function becomes active when only the front cooking zone power display is illuminated.
4. To stop the bridge function, press and hold both Cooking Zone select touch controls for the left hand side cooking zones.

Keep Warm Function

The Keep Warm Function can be used to keep food warm for long periods of time (up to 2 hours). The cookware can be removed from the element for up to 10 minutes without disabling the function.

1. The Cooktop must be set to Operating-Mode.
2. Select one of the cooking zones. Press the Keep Warm Function Touch Control (03) and the Cooking Zone Select touch control & Power LED display of the selected cooking zone will change to "U".
3. The function can be disabled by adjusting the cooking zone power level.

Stop N Go Function

The Stop N Go Function allows you to stop all activity on the Cooktop (cooking, timers) and restart for where you left off at a later time.

1. While the Cooktop is in Operating-Mode, press the Stop N Go/Recall Function Touch Control (02). A pause symbol "II" will appear in each Cooking Zone Select touch control & Power LED display and the indicator above the sensor will light up. All functions will pause, and all touch sensors disabled (except for On/Off Power touch control).
2. Once ready to restart, press the Stop N Go/Recall Function Touch Control (02) again. The indicator above the sensor will flash for 2 seconds. Press any other touch sensor within that 2 seconds and the pause symbols will disappear. The Cooktop will then continue to work as it was before.

Recall Function

There may be times when you are cooking and press the On/Off Power touch control by mistake, deleting all functions and timers. If the On/Off Power touch control is pressed again (within 6 seconds of the Cooktop being set to Stand-By-Mode), the indicator above the Stop N Go/Recall Function Touch Control (02) will flash for 5 seconds. Press the Stop N Go/Recall Function Touch Control while it's flashing, and the previous settings for the Cooktop will be recalled.

TOUCH CONTROL SAFETY FUNCTIONS

The following safety functions are available to avoid unintended operations of the cooktop control:

Pan Detection Failure

If a cooking zone is activated and undersized cookware, incorrect material cookware or no cookware is detected, the symbol U will be displayed on the cooking zone LED display and the cooking zone will be disabled. Place or replace cookware on the cooking zone.

Residual Heat Functions

After all cooking processes there is some heat stored in the glass top called residual heat. The control can calculate roughly how hot the glass is in the worst case. If the calculated temperature is higher than + 60 ° C, then this will be indicated in the corresponding Cooking Zone Select touch control & Power LED display with a red "H" after the cooktop has turned off. The residual heat display is shown as long as the calculated cooking zone temperature is > + 60 ° C.

EXAMPLES OF COOKING ZONE POWER SETTINGS

(The values below are indicative)

1 to 2	Melting Reheating	Sauces, butter, chocolate, gelatine. Dishes prepared beforehand.
2 to 3	Simmering Defrosting	Rice, pudding, sugar syrup. Dried vegetables, fish, frozen products.
3 to 4	Steam	Vegetables, fish, meat.
4 to 5	Water	Steamed potatoes, soups, pasta, fresh vegetables.
6 to 7	Medium cooking Simmering	Meat, eggs, sausages. Goulash, roulade, tripe.
7 to 8	Cooking	Potatoes, fritters, wafers.
9	Frying, roasting Boiling water	Steaks, omelettes, Fried dishes. Water.
P	Frying, roasting Boiling water	Scallops, steaks. Boiling large quantities of water.

AUTO COOKING FUNCTION

HIGH POWER TIMES

Selected power	Time at High (MM:SS)
1	00:48
2	02:24
3	03:36
4	05:24
5	06:48
6	02:00
7	02:48
8	03:36
9	- : -

COOKING ZONE TIME

(BY POWER LEVEL)

POWER LEVEL	OPERATING TIME (HRS:MIN)
1	8:36
2	6:42
3	5:18
4	4:18
5	3:30
6	2:18
7	2:18
8	1:48
9	1:30

CLEANING



NOTE: Cleaning and maintenance operations must only be carried out when the cooktop is cool (all residual heat indicators are off).

The Cooktop should be disconnected from the power outlet or turned off at your isolation switch before commencing any cleaning process.

Do not use plastic, plastic coated or aluminium cooking equipment on this Cooktop.

CLEANING THE COOKTOP

All cookware used on this Cooktop should be rated for induction cooking by the manufacturer. Cookware with rough bases should not be used as they can scratch the glass ceramic surface. The base of the good cookware should be as thick and flat as possible. Before use, make sure that cookware bases are clean and dry.

Always place the cookware on the cooking zone before it is switched on. If possible, always place the lids on the cookware. The base of any cookware used must not be smaller or larger than the cooking zones; they should be the proper size as indicated below, so as not to waste energy.

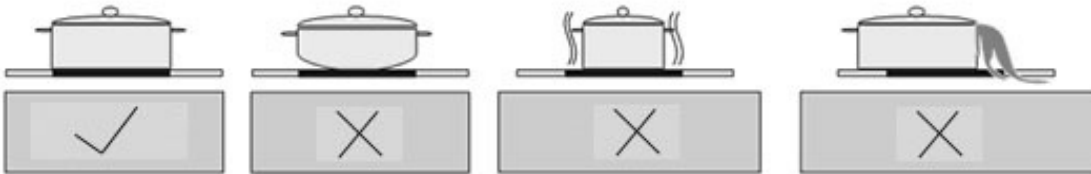

Before cleaning the cooktop, first isolate the cooktop from the power. Once done, ensure that there is no residual heat stored in the Cooktop. The glass is very resistant to high temperature and overheating. If there is residual heat stored in the Cooktop, the related residual heat indicator lamp will be on. In order to avoid burns, let the Cooktop cool down.

Remove all spilt food and fat with a clean damp, warm, slightly soapy, dishcloth. Rinse cloth and wipe cooktop again until clean, then wipe the cooktop dry with a clean tea towel or dry soft cloth.

If aluminium foil or plastic items are accidentally melted on the glass surface, they should be immediately removed from the hot cooking area with a scraper specifically for glass. This will avoid any possible damage to the surface. This also applies to sugar or food containing sugar that may be spilled on the cooktop. Enamelled steel, aluminium & copper will leave a residue on the surface that should be removed immediately or permanent damage may occur.

In the event of other food melted on the cooktop surface, remove the dirt when the Cooktop has cooled down. Use cleaner for glass ceramic or stainless steel when cleaning the surface.

Do not use abrasive sponges to clean the glass surface. These materials may damage the surface.

Do not use chemical detergents, sprays or spot removers on the glass surface. These materials may cause fire or the glass colour to fade. Clean with a damp, warm, slightly soapy, dishcloth.

WARNING: Using cookware that is too large can cause discolouration or damage to the cooktop surface around the cooking zones, which is NOT covered under warranty.

ELECTRICAL CONNECTIONS



LOCAL AUTHORITY REQUIREMENTS

Installation is only permitted by a licensed electrician, and carried out according to instructions provided by the manufacturer. Incorrect installation might cause harm and damage, for which the manufacturer accepts no responsibility.

ELECTRICAL INSTALLATION

Before carrying out the connection to the power supply, the voltage rating of the Cooktop (stamped on the Cooktop identification plate) must be checked for correspondence to the available mains supply voltage, and the mains electric wiring should be capable of handling the oven's power rating (also indicated on the identification plate). If you have any doubts, call in a qualified technician.

NOTE: For connections to the mains power supply, never use adapters, reductions or multiple power points as these may overheat and catch fire. Do not install separate timers.

After having installed the Cooktop, the switched outlet must always be in an accessible position.

The electrical safety of this Cooktop can only be guaranteed if the cooktop is correctly and efficiently earthed, always ensure that the earthing is efficient; if you have any doubts call in a licensed electrician to check the system. The manufacturer declines all responsibility for damage resulting from an installation which has not been correctly earthed.

WARNING: If any damage occurs to the power cable during or after installation, it must be replaced immediately by a licensed electrician with a replacement cable from your Service Centre.

The cooktops can be connected to either a single phase 220-240Vac 50 Hz supply, or 2 phase 380-415Vac 50Hz.

SINGLE PHASE CONNECTION

First, a bridge connection must be made between terminals 1 and 2 (live) and between 3 and 4 (neutral). Connect the pairs to the live and neutral power supply cables. Connect the ground terminal to the ground supply cable.

TWO PHASE CONNECTION

First remove any bridge connection between terminals 1 and 2 (live). Place a bridge connection between 3 and 4 (neutral). Connect terminals 1 and 2 to the live power supply cables. Connect either terminal 3 or 4 to the neutral power supply cable. Connect the ground terminal to the ground supply cable.

The mains terminal block is located on the underside of the cooktop and the terminals are accessible by removing the terminal block cover using a small flat screwdriver.

The Cooktop is designed for fixed connection to the mains. During installation, an all pole disconnecter should be included inside the supply circuit with a contact opening of at least 3mm (rated 32A, delay functioning type). The power supply cord must not touch against any hot surfaces and must be placed so that its temperature does not exceed 75 °C at any point along its length.

IMPORTANT: The Cooktop must NOT be connected to the mains supply by means of a 10A, 15A or 20A plug and socket.

The maximum current drawn in a single phase installation is 32A, and 2x16A for a two phase installation. Only use cables Tmax 90C types H05RN-F, H07RN-F, H05RR-F, H07RR-F etc.

TROUBLESHOOTING AND ERROR CODES

The Cooktop or a cooking zone doesn't start:

- **The electrical connection to the power is faulty – Call an electrician.**
- **A fuse has blown – Check fuse box.**
- **The Key Lock function is active – reset as per the manual.**
- **The control panel buttons are coated in grease or water – clean as per the manual.**
- **An object is covering a control button – in general only one button can be pressed at a time, so remove object to free-up buttons.**

The control panel displays a “U” in one of the Cooking Zone Power LED displays:

- **There is no cookware on the cooking zone – replace cookware on cooking zone.**
- **Cookware cannot be used with induction cooktops - replace cookware.**
- **The size of the base of the cookware is too small - replace cookware.**

The Cooktop or a cooking zone cuts out:

- **A fuse has blown – Check fuse box.**
- **A cooking zone has run unattended for a long period of time so has turned off –reset.**
- **A control panel button has been pressed or covered – remove object and reset.**
- **Cookware is empty and base has overheated – turn off Cooktop, let cool then restart with cookware refilled.**

The control panel LED displays show “Er03”:

- **An object or liquid is covering some or all of the buttons – remove object or carefully clean the liquid away from the control panel.**

The control panel LED displays show “E2” or “EH”:

- **The Cooktop has overheated – remove cookware from top and allow to cool.**

The control panel LED displays show “E3”:

- **The cookware has been detected, but is not suitable – remove cookware and replace.**

The control panel LED displays show “E6”:

- **The Cooktop has detected that the electrical input is not suitable – check power supply.**

The control panel LED displays show “E8”:

- **The Cooktop has detected that the ventilation at the bottom of the Cooktop has become blocked
– check vents are clear & clean, and that fans can be heard starting up periodically.**

The control panel LED displays show “EC” or “E4”:

- **There is a problem with the internal software – reset software (see next page).**

If the problem persists, please contact Omega using the contact details at the end of the manual.

RESETTING THE INTERNAL SOFTWARE SYSTEM

If the error codes EC or E4 appear, please do the following:

- a) Remove all cookware from the cooktop. Have an inductive pot or pan with a bottom diameter of at least 16cm close by for use during the procedure.
- b) Remove the Cooktop from the power supply for a few minutes, by turning the circuit breaker off or removing the fuse.
- c) Reconnect the Cooktop to the power supply. There is now 2 minutes to start the next step, otherwise repeat the above.
- d) **STEP 1:** Without pressing the On/off power touch control, press Boost Power touch control and keep touching with one finger. A “-“ symbol will appear in the four Cooking Zone Select touch control & Power LED displays. While still touching the Boost Power touch control, quickly press each Timer/Zone Power touch control (less than 2 seconds) in succession, starting from RHF, to RHR, LHR and ending at LHF. If a double beep is heard, a mistake has been made & the process needs to start from the beginning. If not, remove all fingers from the control panel and press Simmer Power touch control (03) for a few seconds until flashing “E” symbols appear. Wait until the symbols stop flashing and change to “C” on each LED display. This means the old software has been purged from the Cooktop.
- e) **STEP 2:** Select a cooking zone by pressing the Cooking Zone Select touch control & Power LED display. Place the pot or pan centrally in the cooking zone. Wait for the LED display to change from “C” to a “-“. Repeat for every cooking zone. Do not use multiple pots or pans, or change during the process. Once all the Cooking Zone Select touch control & Power LED displays are showing “-“, the process is finished.
- f) The Cooktop should now turn off and on again correctly. If the error codes persist, please contact the Omega Service Department.



**AUSTRALIAN & NEW ZEALAND PRODUCT WARRANTY
STATEMENT OF STANDARD WARRANTY CONDITIONS**

AUSTRALIAN CUSTOMERS

Our goods come with guarantees that cannot be excluded under the Australian Consumer Law. You are entitled to a replacement or refund for a major failure and for compensation for any other reasonably foreseeable loss or damage. You are also entitled to have the goods repaired or replaced if the goods fail to be of acceptable quality and the failure does not amount to a major failure.

NEW ZEALAND CUSTOMERS

Nothing herein contained shall be construed in any way as excluding or limiting your rights under the Consumer Guarantee Act 1993.

OUR WARRANTY

This product is also covered by the manufacturer's warranty set out in this document (Our Warranty).

Our Warranty is for a period of twenty four (24) months from the date of purchase and for refrigeration appliances will have an additional thirty six (36) months after the first twenty four (24) months on the Sealed System (PARTS only) Compressor & condenser etc. The labour cost to replace these parts is the responsibility of the customer.

This is in addition to (and does not exclude, restrict or modify) any rights or remedies to which you may already be entitled to under the Australian consumer law or the New Zealand Consumer Guarantee act 1993 relating to this product.

Our warranty (which is subject to the conditions below) covers rectification free of charge of any fault arising from defective materials or components, or faulty workmanship. The product will be repaired or replaced at the option of Omega, and all costs of installation, removal, cartage, freight travelling and insurance are to be paid by the customer.

Our warranty is subject to the following conditions:

1. That the purchaser contact Omega prior to any product repair.
2. That the purchaser carefully follows all instructions provided with the product and complies with all relevant electrical & plumbing regulations in their State when installing the product.
3. That the purchaser carefully follows the instructions provided in the owner's handbook relating to the proper use and care of the product and does not use the product for any purpose other than the DOMESTIC use for which it has been designed. If the appliance is used in commercial applications or for rental purposes, Our Warranty is limited to a warranty of Twelve (12) months covering all parts with Three (3) months on any labour cost of service or repair.

SERVICE AREA

The provision of service under Our Warranty is limited by the boundary/ territory area of the nearest service centre. Travelling cost incurred for service outside this area is not covered by Our Warranty and service will incur commercial cost to be paid by the customer regulated by the number of kilometres travelled beyond the service area. These costs will be disclosed to you for acceptance by you prior to your claim being processed.

Microwave ovens must be returned to your nearest Authorised Service Centre for repairs as they are a carry in serviceable Cooktop.

WHAT IS COVERED: By Our Warranty

During the warranty period, Omega or its authorised Service Centre will, at no extra charge, if your Cooktop is readily accessible without the need of special equipment and subject to the terms and conditions of this warranty, repair or replace any parts which it considers defective.

WHAT IS NOT COVERED: By Our Warranty

1. Products installed damaged or incomplete or not in compliance with the relevant electrical & plumbing regulations in their State.
2. Normal wear and tear e.g. cleaning, light globes, filters etc.
3. Failure resulting from power surges and electrical storms.
4. Insect or vermin infestation.
5. Unauthorised repairs or use of non-genuine Omega parts.
6. Any failure caused by the product not being used in accordance with the instruction and the installation manual provided with the product.
7. Misuse or abuse, including failure to properly maintain or service.
8. The clearing of blockages in pumps and hoses.
9. Damage which occurs during delivery or installation.
10. Claims to product surface coating due to liquid or solid spill-overs, accidental damage or damage caused from cleaning products not recommended by Omega.

HOW TO CLAIM OUR WARRANTY

You will need to contact Omega in Australia or New Zealand by using the contact details below.

IN AUSTRALIA

Omega is a division of Shiro Australia Pty Ltd
ABN 28 00 2 386 129
Locked Bag 5002, Kingsgrove, NSW, 2208
Phone: 1300 795 572 Fax: 1800 686 413
Email: customercare@shiro.com.au
Web: www.omegaappliances.com.au

IN NEW ZEALAND

Omega is a division of Monaco Corporation
(Member of Shiro Australia Pty Ltd)
PO Box 4399, Shortland St, Auckland, 1140
Phone: 09 415 6000 Fax: 09 415 7060
Email: service@shiro.com.au

Note: Please complete the following details when you have unpacked the product:

Model No.

Serial No

Date of Purchase.....

Retailer.

