BERTAZZONI
ISTRUZIONI PER L'INSTALLAZIONE, ED USO
PIANI A INDUZIONE

BERTAZZONI
INSTALLATION AND USE INSTRUCTIONS
INDUCTION COOKTOPS

BERTAZZONI
MANUEL D'INSTALLATION ET D'UTILISATION
PLAQUES DE CUISSON À INDUCTION

BERTAZZONI
AANWIJZINGEN VOOR DE INSTALLATIE EN HET GEBRUIK
INDUCTIEKOOKPLATEN

BERTAZZONI
INSTALLATIONS- OCH BRUKSANVISNINGAR
INDUKTIONSHÄLLAR

BERTAZZONI
INSTALLATIONS- OG BETJENINGSVEJLEDNING
INDUKTIONSKOGEPLADER

IT

EN

FR

NL

SW

DK



P604I2M28NV

WWW.BERTAZZONI.COM

Safety Warnings

Your safety is important to us. Please read this information before using your cooktop.

- The appliance must not be used by persons (including children) with reduced physical, sensory or mental capabilities, or lack of experience and knowledge, unless they have been given supervision or instruction. Make sure that children do not to play with the appliance.
- Warning: Hob surfaces made of glass-ceramic or similar materials protect the live parts, so switch off the appliance to avoid the possibility of electric shock if the surface is cracked
- Warning: Do not use a stem cleaner. Do not place metal objects such as knives, forks, spoons and lids on the hob surface since they may become hot.
- After use, switch off the hob element with its control and do not rely on the pan detector. The appliance is not intended to be operated by means of an external timer or separate remote-control system.
- Fire hazard: Do not store items on the cooking surfaces.
- CAUTION: The cooking process has to be supervised. A short term cooking process has to be supervised continuously.
- WARNING: Cooking with fat or oil on an unattended hob can be dangerous and may result in fire.

- If the power cable is damaged, it must be replaced by the manufacturer, its service agent or other similarly qualified persons in order to avoid a hazard.
- This appliance can be used by children aged from 8 years and above and persons with reduced physical, sensory or mental capabilities or lack of experience and knowledge if they have been given supervision or instruction concerning use of the appliance in a safe way and understand the hazards involved. Children may not play with the appliance. Children may not carry out cleaning and user maintenance without supervision.
- **WARNING:** The appliance and its accessible parts become hot during use.
- Take care to avoid touching the heating elements.
- Keep children less than 8 years of age away unless continuously supervised.
- **WARNING:** Cooking with fat or oil on an unattended hob can be dangerous and may result in fire.
- **NEVER** try to extinguish a fire with water, but switch off the appliance and then cover the flames e.g. with a lid or a fire blanket.
- **CAUTION:** The cooking process has to be supervised. A short term cooking process has to be supervised continuously.
- **WARNING:** Fire hazard: do not store items on the cooking surfaces.

- **WARNING:** Use only hob guards designed by the cooking appliance manufacturer or indicated as being suitable in the appliance manufacturer's instructions for use, or hob guards incorporated into the appliance. The use of inappropriate guards can cause accidents.
- The power cable must be inaccessible after installation.

Congratulations on the purchase of your new Induction Hob.

We recommend that you spend some time to read this Instruction / Installation Manual in order to fully understand how to install it correctly and operate it.

For installation, please read the installation section.

Read all the safety instructions carefully before use and keep this Instruction / Installation Manual for future reference.









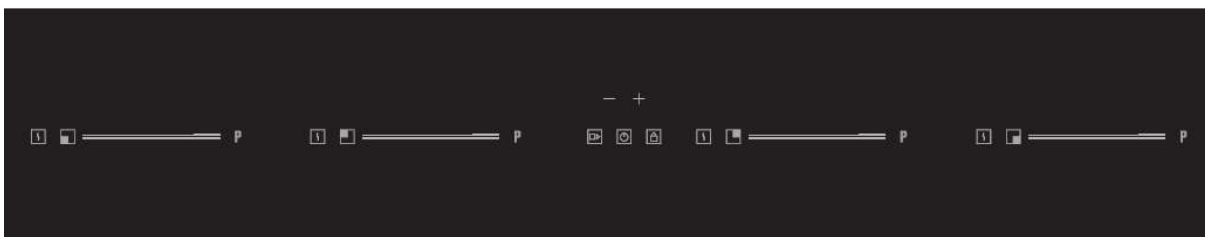

Product Overview

Top View



User interface



Reference	Description
A 	ON/OFF key
B 	Child lock key
C 	Pause key
D 	Timer control keys & Timer setting indicator
E Power slider 	
F 	Boost control key
G 	Cooking functions key
H 	Timer setting indicator
I 	Power level indicator
J 	Timer Indicator
K 	Cooking functions indicator

Heating Zone Power

Heating Zone	Total Power (220–240V ~ 50/60Hz)
Front left zone	2000/2500/2800W (Booster)
Rear left zone	1500/1800/200 (Booster)
Rear Right zone	1500/1800/200 (Booster)
Front Right zone	2000/2500/2800W (Booster)
Total Rating Power	7200W (230V ~)

A Word on Induction Cooking

Induction cooking is a safe, advanced, efficient, and economical cooking technology. It works by using electromagnetic vibrations to generate heat directly in the pan, rather than indirectly through heating the glass surface. The glass only becomes hot because the pan eventually warms it up.

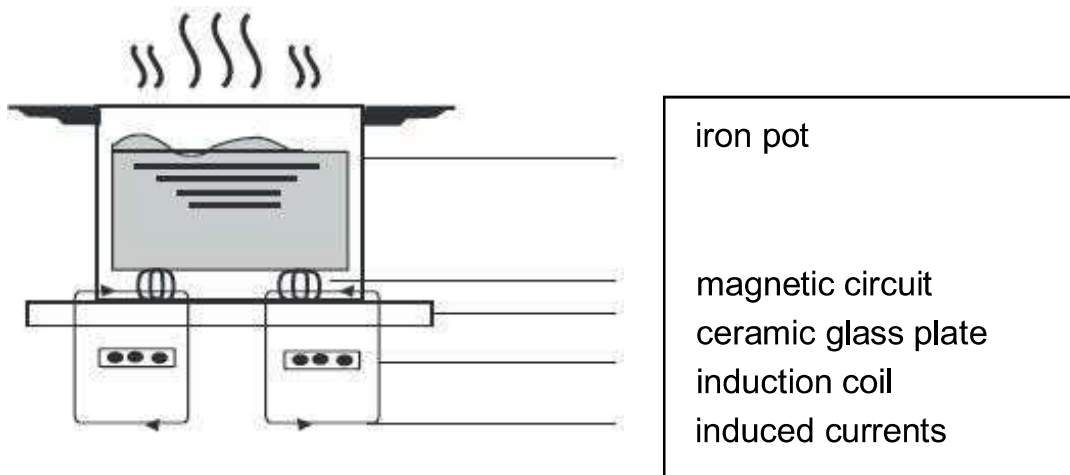

Before using your New Induction Hob

- Read this guide, taking special note of the 'Safety Warnings' section.
- Remove any protective film that may still be on your induction hob.

Using the Touch Controls

- The controls respond to touch, so you don't need to apply any pressure.
- Use the ball of your finger, not its tip.
- You will hear a beep each time a touch is registered.
- Make sure the controls are always clean and dry, and that there are no objects (e.g. a utensil or cloth) covering them. Even a thin film of water may make the controls difficult to operate.

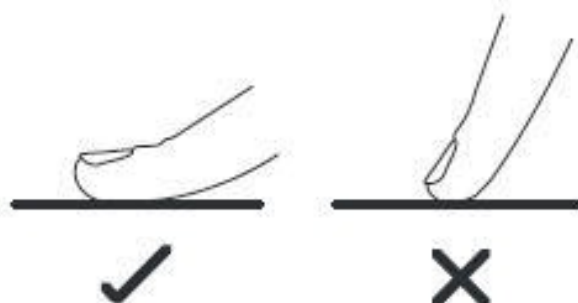

Choosing the right Cookware



- Only use cookware with a base suitable for induction cooking. Look for the induction symbol on the packaging or on the bottom of the pan.

- You can check whether your cookware is suitable by carrying out a magnet test. Move a magnet towards the base of the pan. If it is attracted, the pan is suitable for induction.

- If you do not have a magnet:

1. Put some water in the pan you want to check.

2. If  does not flash on the display and the water is heating, the pan is suitable.

- Cookware made from the following materials is not suitable: pure stainless steel, aluminium or copper without a magnetic base, glass, wood, porcelain, ceramic, and earthenware.

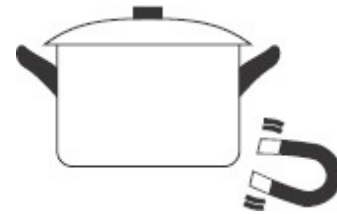

Do not use cookware with jagged edges or a curved base.



Make sure that the base of your pan is smooth, sits flat against the glass, and is the same size as the cooking zone. Use pans with diameters as large as the graphic on the selected zone. A slightly wider pan will use energy most efficiently. Efficiency may be less than expected if you use a smaller pan. The hob may not detect a pan smaller than 140 mm. Always centre your pan on the cooking zone.

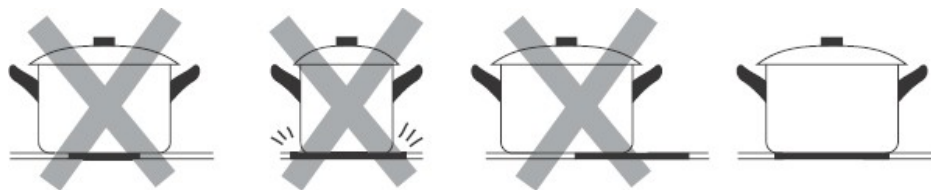

Always lift pans off the Induction hob - do not slide them as they may scratch the glass.

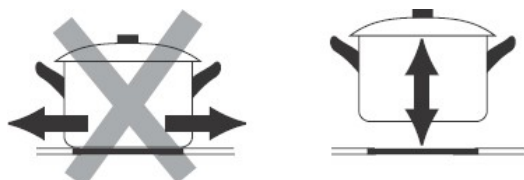

Special functions

Over-Temperature Protection

A temperature sensor has been installed to monitor the temperature inside the Induction hob. When an excessive temperature is detected, the Induction hob will stop operation automatically.

Detection of Small Articles

When an unsuitable size or non-magnetic pan (e.g. aluminium), or some other small item (e.g. knife, fork, key) has been left on the hob, the hob automatically goes into standby in 1 minute. The fan will continue cooling the induction hob for a further 1 minute.

Auto Shutdown Protection

Auto shutdown is a safety function to protect your induction hob. It shuts down automatically if you ever forget to turn off your hob. The default working times for various power levels are shown in the below table:

Power level	1~3	4~6	7~8	9
Default working time (min)	360	180	120	90

When the pan is removed, the induction hob stops heating immediately and the hob will automatically switch off after 2 minutes.



People with a heart pace maker should consult their doctor before using this unit.

Auto Pan Detect

This function automatically detects where the pot or pan is located. The bridge functions is activated automatically, depending on the size of the pot or pan. You just need to power up with the slider.

Using your Induction Hob

To start cooking

1. Touch the ON/OFF (A) control for 3 seconds.
After power on, the buzzer beeps once; all displays show " - " to indicate that the induction hob has entered standby mode.

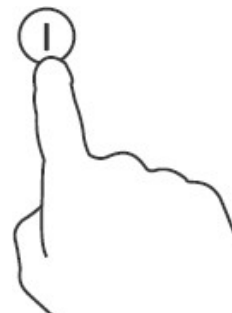

2. Place a suitable pan on the cooking zone that you wish to use.
 - Make sure the bottom of the pan and the surface of the cooking zone are clean and dry.

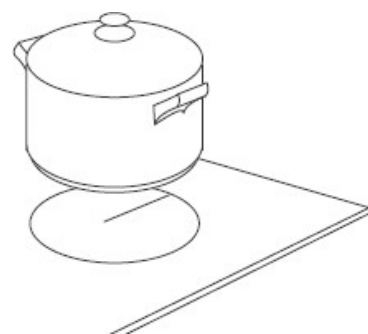

3. Adjust heat setting by touching the slider control (E) for the heating zone where the pan is placed.

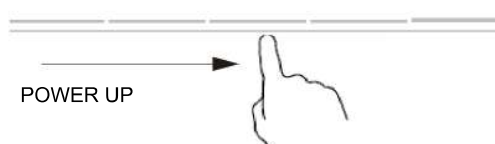
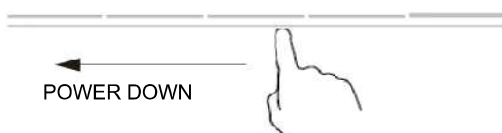

- If you do not choose a heat setting within 20 seconds, the induction hob will automatically switch off. In this case, you will need to start again at step 1.
- You can modify the heat setting at any time during cooking.

If the display flashes alternately with the heat setting

This means that:

- you have not placed a pan on the correct cooking zone or,
- the pan you are using is not suitable for induction cooking or,
- the pan is too small or not properly centred on the cooking zone.

No heating takes place unless there is a suitable pan on the cooking zone. The display will automatically turn off after 1 minute if no suitable pan is placed on it.

When you have finished cooking

1. Touch the slider (E) to decrease the power level to "0".

2. Beware of hot surfaces

"H" will show which cooking zone is hot to the touch. It will disappear when the surface has cooled down to a safe temperature. You can save energy by using a hotplate that is still hot if you want to heat more pans.

Using the Boost function

Activating the boost function

Touch the boost control key (F); the zone indicator will show "P." and the power will reach Max.

Touch the boost control key (F); the zone indicator will show "d" and the power will be boosted to double.

Cancelling the Boost function

Touch the slider control (E) to cancel the Boost function; the cooking zone will then revert to the power you wish.

- This function can work in any cooking zone.
- The cooking zone returns to level 9 after 5 minutes.

Using Cooking Functions

You can choose 3 handy cooking functions by pressing the cooking functions key (G); moves from one function to the next on each press.



- Melt or defrost (about 50°C)



- Heating or keeping warm (about 70°C)



- Simmering, temperature close to boiling, useful for slow cooking

FLEXIBLE AREA

- This area can be used as a single zone, depending on your cooking needs at any time.
- The flexible area is composed of two independent inductors that can be controlled separately. When working as a single zone, cookware is moved from one zone to the other within the flexible area while maintaining the same power level in the zone where the cookware was originally placed. The part that is not covered by cookware is automatically switched off.
- **Important:** Take care to centre the cookware on the single cooking zone. An oval or rectangular saucepan is ideal.

Examples of good and bad pan placement.

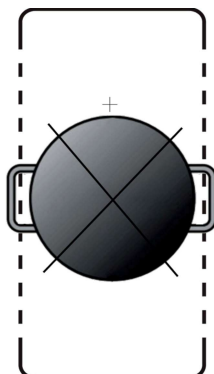
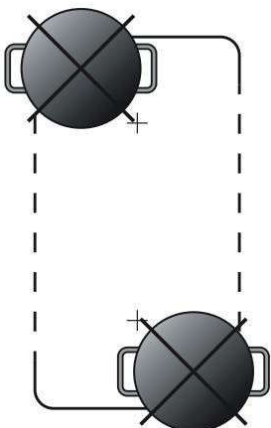
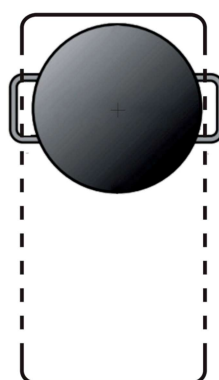
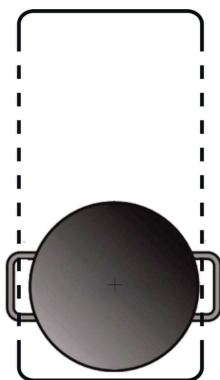
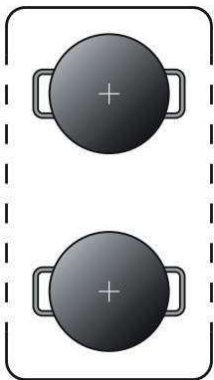

1. To activate the flexible area as a single big zone, simply press the same time related heating zone power slider regulating key at least 2 second

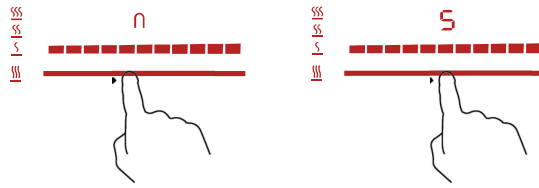

2. The flexible zone indicator next to the power lever indicator will be light up.



3. According to the heating zone where the pan is placed, adjust heat setting by touching the front left zone or the front right zone slider regulating key(E) control.

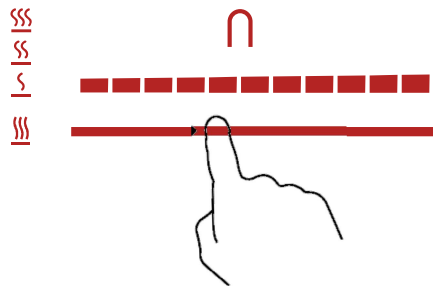

4. If the pot is moved from the front to the rear part (or viceversa),the flexible area detects automatically the new position, keeping the same power.

Using the Child Lock Function

- You can lock the controls to prevent unintentional use (for example, children accidentally turning the cooking zones on).
- When the controls are locked, all controls except the ON/OFF (A) control are

disabled. To lock the controls

Touch the child lock key for 3 seconds. The indicator above the child lock key will be on and the timer indicator will show "Lo"

To unlock the controls

1. Touch and hold the keylock control for a while
2. You can now start using your induction hob



When the hob is in lock mode, all controls are disabled except OFF. You can always turn the hob off with the OFF control in an emergency, but you must unlock the hob before any further operations

Using the Timer

You can use the timer in two different ways:

- You can use it as a minute minder. In this case, the timer will not turn any cooking zone off when the set time is up.
- You can set it to turn one cooking zone off when set time is up.
- You can set the timer for up to 99 minutes.

Using the Timer as an alarm

1. After selecting the cooking zone and required power level, the dot next to power level indicator will flash for 5 seconds



2. When the dot stops flashing, touch the timer control key (D) "-" or "+" to set the time from 1 to 99 minutes.

Hint: Touch the "-" or "+" timer keys once to decrease or increase by 1 minute. Touch and hold the "-" or "+" timer keys to decrease or increase by 10 minutes.

3. When the time is set, it will begin to count down immediately. The display will show the remaining time and the dot next to the timer indicator will continue flashing.



4. The buzzer will beep and the timer indicator will turn off when the set time has elapsed.

Setting the timer to switch off zones

1. After selecting the cooking zone and required power level by touching the power slider (E), the dot next to power level indicator will flash for 5 seconds
2. Before the dot stops flashing, touch the timer control key (D) "-" or "+" to set the time from 1 to 99 minutes.

Hint: Touch the "-" or "+" timer keys once to decrease or increase by 1 minute. Touch and hold the "-" or "+" timer keys to decrease or increase by 10 minutes.

3. When the time is set, it will begin to count down immediately. The timer setting indicator (J) will show the remaining time and the timer indicator will flash for 5 seconds.
4. After that, if the indicator (J) continues flashing, it means that the timer setting indicator shows the remaining time until the timer expires for the corresponding zone, otherwise the indicator (J) will remain lit until the time elapses.
5. When the cooking timer has elapsed, the corresponding cooking zone will switch off automatically. Other cooking zones will keep operating if they were turned on previously.
6. When simultaneously using "the timer as an alarm" and "the timer to switch off the zones", the display will show the remaining alarm time as its first priority. Press the cooking zone power slider (E) to show the remaining time of the switch-off timer.

Using the Pause function





The hob has a handy restart function to pause and restart the cooking process if you are interrupted.

1. When the hob is on and working, press the pause key (C) ; all burners will stop working and all LED indicators will show the symbol “=”
2. Press the pause key (C) again; all parameters will return to their previous settings.

Power Limitation Adjustment Instruction (1.5kW / 2.8kW / 3.7kW / 4.5kW / 6.0kW / 6.5kW / 7.2kW)

ATTENTION! : Only the authorized service representative may make this adjustment!

Make sure the hob is switched off. The required power level can be set by carrying out the following steps within 60 seconds:

Step	Control Panel Operation	Display
1	 <p>When the hob is turned off, temperature manager key and timer key.</p>	
2	<p>The LED display shows the power levels.</p>	
3	<p>Press the + and - keys to choose the power limitation.</p>	<p>Select 1.5/2.8/3.7kW/4.5kW/6.0kW/6.5kW/7.2kW alternative</p>
4	 Press pause key to quit	<p>Quit setting</p>

Failure Display and Inspection

If a fault occurs, the induction hob will enter the protection state automatically and display the corresponding error codes:

Error Message	Possible Cause	What to do
	No pan or pan unsuitable;	Replace the pan:
ER03	Water or pan on the glass over the control	Clean the user interface
F1E	The connection between the display board and the left mainboard has failed (in the cooking zone for which the indicator is showing "E")	1. Connection cable not plugged in properly or defective; Replace the mainboard.
F3E	Coil temperature sensor failure. (in the cooking zone for which the indicator is showing "E")	Replace the coil sensor
F4E	Mainboard temperature sensor failure. (in the cooking zone for which the indicator is showing "E")	Replace the mainboard
E1E	Temperature sensor of the ceramic glass plate is high	Please restart after the induction hob has cooled down.
E2 E	Temperature sensor of the IGBT is high	Please restart after the induction hob has cooled down.
E3 E	Abnormal supply voltage (too high)	Please check that the power supply is normal; Power on when the power supply is normal.
E4 E	Abnormal supply voltage (too low)	Please check that the power supply is normal; Power on when the power supply is normal.
E5 E	Temperature sensor failure (in the cooking zone for which the indicator is showing "E")	Connection cable not plugged in properly or defective assembly;

The above are causes and solutions of the most common failures.

Do not disassemble the unit by yourself to avoid any hazards and damage to the induction hob, and **please contact the supplier.**

Installation

Choosing installation equipment

Cut out the work surface according to the sizes shown in the drawing.

Leave a space of at least 5 cm around the hole for the purpose of installation and use.

Make sure the work surface is at least 30 mm thick. Please select a heat-resistant work surface material to avoid extensive deformation due to the heat radiated by the hotplate.

As shown below:

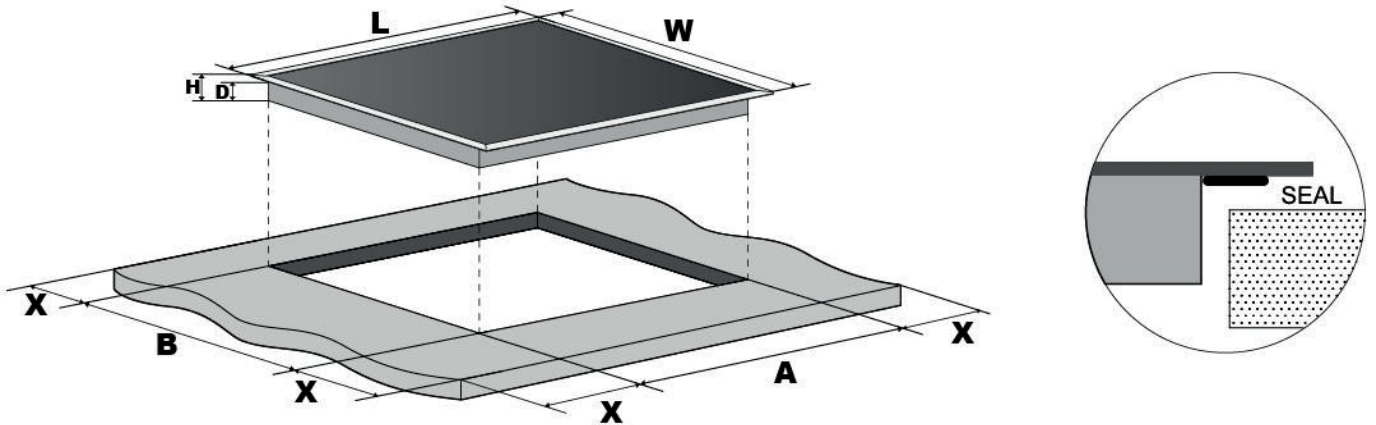

L(mm)	W(mm)	H(mm)	D(mm)	A(mm)	B(mm)	X(mm)
590	520	60	55	560	490	50 min.

Under all circumstances, make sure the induction hob is well ventilated and that the air inlet and outlet are not blocked. Ensure the induction hob is in good working condition as shown below.

- Note: Leave a safety distance of at least 700 mm between the hotplate and the cupboard above the hotplate. If over the hob a hood is installed, keep as reference the distance indicated into the hood user manual.

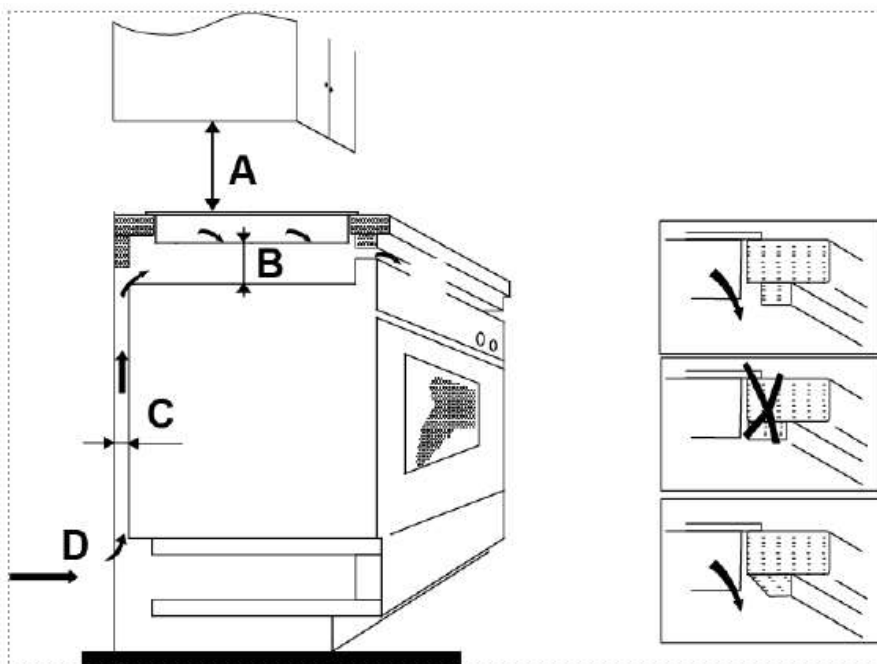

A(mm)	B(mm)	C(mm)	D
700	20 min.	20 min.	Air intake

Before installing the hob, make sure that

- the work surface is square and level, and no structural members interfere with the space requirements
- the work surface is made of heat-resistant material
- if the hob is installed above an oven, the oven has a built-in cooling fan
- the installation will comply with all clearance requirements and applicable standards and regulations
- a suitable isolating switch providing full disconnection from the mains power supply is incorporated into the permanent wiring, and is installed and positioned in accordance with the local wiring rules and regulations.

The isolating switch must be of an approved type and provide a 3 mm contact separation (air gap) on all poles (or all active [phase] conductors if the local wiring rules allow for this variation of the requirements)

- the customer will be able to access the isolating switch easily with the hob installed
- you consult local building authorities and by-laws if in doubt regarding installation
- you use heat-resistant finishes that are easy to clean (such as ceramic tiles) for the wall surfaces surrounding the hob.

After installing the hob, make sure that

- the power supply cable is not accessible through cupboard doors or drawers
- there is adequate flow of fresh air from outside the cabinetry to the base of the hob
- if the hob is installed above a drawer or cupboard space, a thermal protection barrier is installed below the base of the hob to avoid touching the bottom of the hob.
- the customer can easily access the isolating switch

The unit should be placed on a stable, smooth surface (use the packaging). Do not apply force to the controls protruding from the hob.

Product placement

- The unit should be placed on a stable, smooth surface (use the packaging). Do not apply force to the controls protruding from the hob.

fig. 1

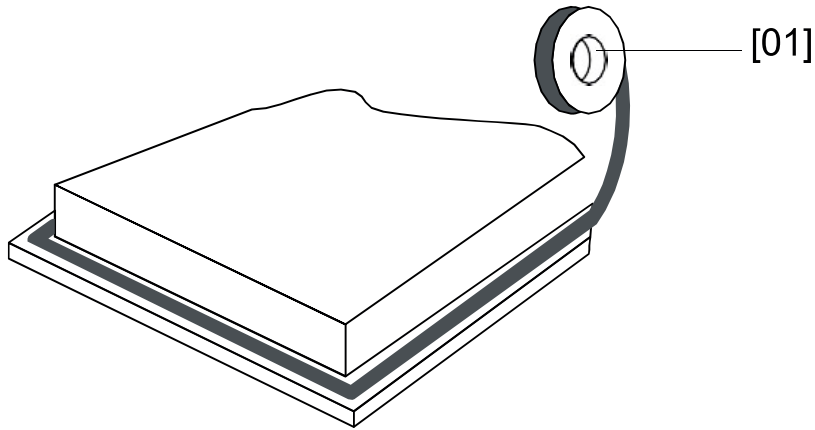

01



Stretch out the supplied seal along the bottom edge of the hob, ensuring the ends overlap.

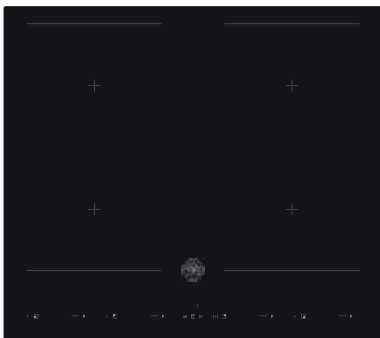
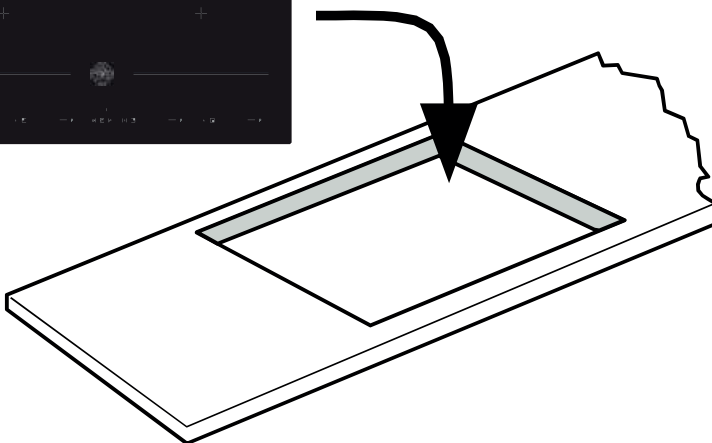

fig.
2



Do not use adhesive to fix the hob into the worktop.

Once the seal is fitted, position the hob into the cut-out in the worktop. Apply gentle downwards pressure onto the hob to push it into the worktop and ensure a good seal around the outer edge

Cautions

1. Only qualified personnel or technicians may install the induction hotplate. Our professionals at your service. Please never carry out the operation by yourself.
2. Do not install the hob directly above a dishwasher, fridge, freezer, washing machine or clothes dryer, as the humidity may damage the hob electronics
3. Install the induction hotplate in such a way as to ensure good heat radiation to enhance its reliability.
4. The wall and induced heating zone above the table surface must be heat resistant.
5. To avoid any damage, the sandwich layer and adhesive must be heat resistant.

Connecting the hob to the mains power supply



Only a suitably qualified person may connect this hob to the mains power supply. Before connecting the hob to the mains power supply, check that:

1. the domestic wiring system is suitable for the power drawn by the hob.
2. the voltage matches the value given in the rating plate
3. the power supply cable sections can withstand the load specified on the rating plate. When connecting the hob to the mains power supply, do not use adapters, reducers or branching devices as they can cause overheating and fire.

The power supply cable must not touch any hot parts and must be positioned to ensure that its temperature will not exceed 75°C at any point.



Check with an electrician whether the domestic wiring system is suitable without alterations. Only a qualified electrician may make any alterations.

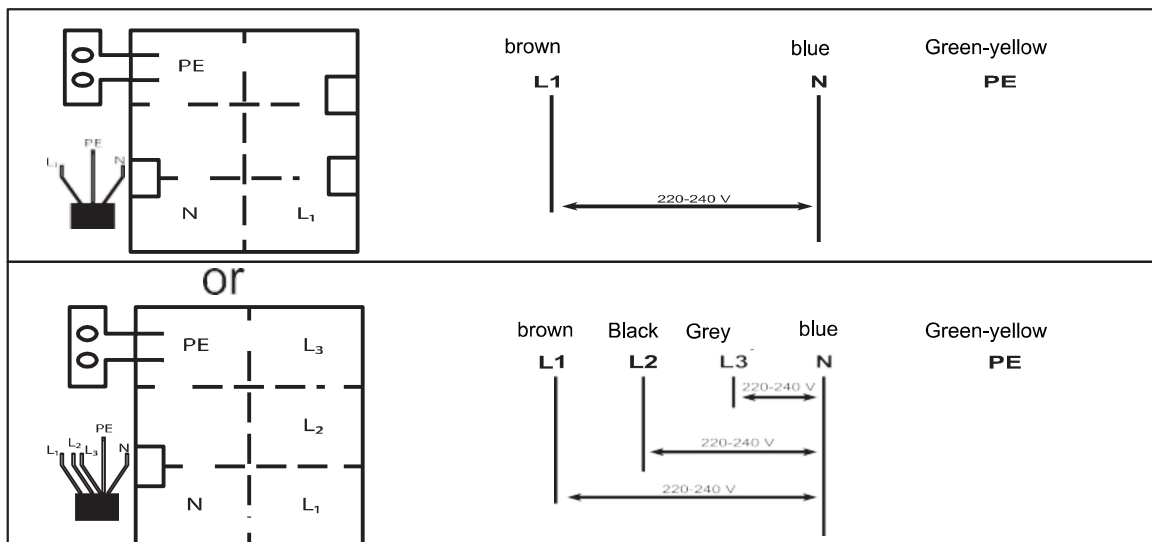

- If the cable is damaged or needs to be replaced, this must be carried out the by after-sale agent with dedicated tools to avoid any accidents.
- If the appliance is being connected directly to the mains, install an omnipolar circuit-breaker with a minimum opening of 3mm between contacts.
- The installer must ensure that the correct electrical connection has been made and that it is compliant with safety regulations.
- The cable must not be bent or compressed.
- The cable must be checked regularly. Only authorised technicians may replace it.

This appliance requires a 32 Amp Miniature Circuit Breaker.

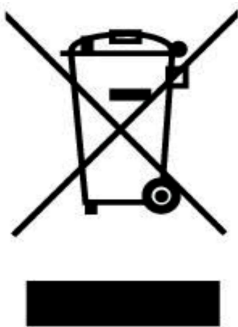
 <p>DISPOSAL: Do not dispose of this product as unsorted municipal waste. Such waste must be collected separately for special treatment.</p>	<p>This appliance is labelled in compliance with European Directive 2011/65/EU on Waste Electrical and Electronic Equipment (WEEE). By ensuring that this appliance is disposed of correctly, you will help prevent any possible damage to the environment and to human health that might otherwise occur if it were disposed of inappropriately.</p> <p>The symbol on the product indicates that it may not be treated as normal household waste. It should be taken to a collection point for recycling of electrical and electronic goods.</p> <p>This appliance requires specialist waste disposal. For further information regarding the treatment, recovery and recycling of this product, please contact your local council, your household waste disposal service, or the shop where you purchased it.</p> <p>For more detailed information about treatment, recovery and recycling of this product, please contact your local council, your household waste disposal service or the shop where you purchased it.</p>
--	---