88L
Upright Freezer,
MUF88B
MUF88S
MUF88W

Welcome

Residentia Group

—

Head Office

165 Barkly Avenue
Burnley, Victoria
Australia 3121

—

ACN

600 546 656

—

Online

residentia.group
www.mykin.house

—

Postage

PO Box 5177
Burnley, Victoria
Australia 3121

—

Telephone

1300 11 4357

Congratulations on purchasing your new Upright Freezer. The Mykin brand is proudly distributed within Australia by Residentia Group Pty Ltd.

Please refer to the warranty card at the rear of this manual for information regarding your product's parts and labour warranty, or visit us online at: www.residentia.group

At Residentia Group, we are customer obsessed and our Support Team are there to ensure you get the most out of your appliance. Should you want to learn more about your new dishwasher, it's features or importantly taking care of the appliance, our Support Team are here to help.

You can use our online Support Centre at anytime by visiting: <http://support.residentiaigroup.com.au>

Or you can contact us via phone by dialing: 1300 11 HELP (4357).

It is important that you read through the following use and care manual thoroughly to familiarise yourself with the installation and operation requirements of your appliance to ensure optimum performance.

Again, thank you for choosing a Mykin appliance and we look forward to being of service to you.

Kind Regards,
The Residentia Team

Content

**PAGE 02
WELCOME**

**PAGE 04
SAFETY WARNINGS**

**PAGE 07
PRODUCT OVERVIEW**

**PAGE 08
GETTING STARTED**

**PAGE 08
INSTALLATION**

**PAGE 10
USING YOUR
UPRIGHT FREEZER**

**PAGE 11
USAGE TIPS**

**PAGE 11
ENERGY SAVING TIPS**

**PAGE 12
MAINTENANCE
AND CLEANING**

**PAGE 14
FAQS AND
TROUBLESHOOTING**

**PAGE 15
SPECIFICATIONS**

**PAGE 16
PURCHASE DETAILS**

**PAGE 17
YOUR RECEIPT**

**PAGE 18
WARRANTY**

Safety Warnings

IMPORTANT SAFETY INSTRUCTIONS READ CAREFULLY AND KEEP FOR FUTURE REFERENCE

Read this manual thoroughly before first use, even if you are familiar with this type of product. The safety precautions enclosed herein reduce the risk of fire, electric shock and injury when correctly adhered to. Make sure you understand all instructions and warnings.

Keep the manual in a safe place for future reference, along with the completed warranty card and purchase receipt. If you sell or transfer ownership of this product, pass on these instructions to the new owner.

Always follow basic safety precautions and accident prevention measures when using an electrical appliance, including the following:

IMPORTANT: Pay particular attention to messages that contain the words **DANGER, WARNING** or **CAUTION**. These words are used to alert you to a potential hazard that can seriously injure you and others. The instructions will tell you how to reduce the chance of injury and let you know what can happen if the instructions are not followed.



This symbol alerts you to take care as this appliance contains a flammable refrigerant (isobutane) and insulation blowing gas (cyclopentane). Do not expose it to high heat, sparks and open flames.

The refrigerant isobutane (R600a) is contained within the refrigerant circuit of the appliance, a gas with a high level of environmental compatibility, which is nevertheless flammable. During transportation and installation of the appliance, ensure that none of the components of the refrigerant circuit become damaged.

WARNING: Do not damage the refrigerant circuit! Never use an appliance with a damaged refrigerant circuit! If the refrigerant circuit becomes damaged, avoid proximity to open fires and all types of heat and ignition sources. Thoroughly ventilate the room in which the appliance is located.

DANGER: It is hazardous for anyone other than an authorised service person to service this appliance. In Queensland, the authorised service person MUST hold a Gas Work Authorisation for hydrocarbon refrigerants to carry out servicing or repairs which involve the removal of covers.

The room for installing the appliance must be at least 1m³ per 8g of refrigerant. The amount and type of refrigerant in the appliance can be found in the Technical Specifications on page 17 and on the rating plate, found on the appliance.

Usage Conditions and Restrictions

- **Domestic use only:** This appliance is intended for indoor household use only. It is not intended for commercial, industrial or outdoor use. It is not intended for use in a recreational vehicle.
- **Purpose:** Do not use this appliance for anything other than its intended purpose. Other uses are not recommended and may cause fire, electric shock or personal injury.
- **Attachments:** The use of attachments is not recommended by the appliance manufacturer and distributor as they may be hazardous.
- **Improper use:** Damage due to improper use, or repairs made by unqualified personnel will void your warranty. We assume no liability for any eventual damages caused by misuse of the product or noncompliance with these instructions.

Safety Warnings (Continued)

General Safety Instructions Cont.

- **WARNING:** Do not use mechanical devices or other means to accelerate the defrosting process, other than those recommended by the manufacturer.
- **Usage restriction:** This appliance is not intended for use by persons (including children) with reduced physical, sensory or mental capabilities, or lack of experience and knowledge, unless they have been given supervision or instructions concerning use of the appliance by a person responsible for their safety.
- **Children:** Supervise young children to ensure they do not play with the appliance. Never allow children to operate, play with or crawl inside the appliance.
- **WARNING:** Do not use electrical appliances inside the appliance, unless they are of the type recommended by the manufacturer.
- **Explosive or flammable substances:** Do not store explosive substances such as aerosol cans with a flammable propellant in this appliance. Do not store or use petrol or any other flammable vapours and liquids in the vicinity of this or any other appliance. Do not use such substances for cleaning the appliance. The fumes can create a fire hazard or an explosion.
- **Damage:** Do not use the appliance if the power cord, plug or the appliance itself is damaged. If the cord is damaged, contact the after sales support line and have the cord replaced by qualified personnel in order to avoid a hazard.
- **WARNING:** Do not damage the refrigerant circuit.
- **Do not modify:** Do not attempt to alter or modify this appliance in any way.
- **Repair:** Do not attempt to repair or replace any part of this appliance unless it is specifically recommended in this manual. All other servicing should be referred to a qualified technician. Contact the after sales support line for advice.
- **WARNING:** Do not locate multiple portable socket-outlets or portable power supplies at the rear of the appliance
- **CAUTION:** Do not touch frozen food or freezer walls with wet hands as this may cause frostbite or skin injury.

Electrical Safety

- **Voltage:** Before connecting and turning on the appliance, ensure the electrical voltage and circuit frequency correspond to that indicated on the appliance rating label.
- **Earthing:** This appliance should be properly earthed for your safety. The power cord of this appliance is equipped with a three-prong plug for use in standard wall outlets to minimise the possibility of electrical shock. Do not modify the cord and/or plug provided with the appliance. Improper use of the earthed plug can result in the risk of electric shock.
- **Connection:** This appliance requires a standard 220-240 V AC 50Hz electrical outlet. Do not overload the electrical circuit.
- **Power cord:** Do not kink or damage the power cord; do not leave it exposed or dangling. Secure it at the back of the appliance so no one steps on or places anything on the cord or against it. Keep the cord out of reach of children. When moving the appliance, make sure not to damage the power cord.
- **WARNING:** When positioning the appliance, ensure the supply cord is not trapped or damaged.
- **Auxiliary Items:** Do not use an inverter, adaptor or extension cord with this appliance. If the cord is too short, have a qualified electrician install an outlet near the appliance. Use of an extension cord and an inverter can negatively affect the performance of the unit.
- **Protect from moisture:** To protect against the risk of electric shock, do not immerse the unit, cord or plug in water or spray it with any other liquid. Do not connect or disconnect the electric plug when your hands are wet. Turn the power switch off before removing the plug from the socket.
- **WARNING: Disconnect!** To reduce the risk of fire, electric shock or personal injury, always unplug the appliance from the socket when not in use, when moving and before cleaning or servicing. Never unplug the unit by pulling the power cord. Always grip the plug firmly and pull straight out from the power point.

Safety Warnings (Continued)

- **Electrical work:** Any electrical work required for the installation of this appliance should be carried out by a qualified electrician.
- **Note:** Use of a surge protector is recommended in areas with unstable power supply.

Never use this appliance with a damaged refrigerant circuit! If the coolant circuit becomes damaged, avoid proximity to open fires and all types of heat sources. The room in which the appliance is located should be ventilated for a few minutes.

Installation

Heavy: This appliance is heavy, take care when moving it. To avoid back or other injury, consider a two person lift or mechanical aid when installing it. Failure to do so can result in back or other injury.

Damage: When unpacking, check the appliance carefully for damage. If it is damaged, do not install the appliance. Contact our after sales support centre on 1300 43 57 for advice on examination or return of the damaged appliance.

Protect from moisture: Install the appliance in an indoor area protected from wind, rain, water spray or drips.

Protect from heat: Do not install the appliance next to an oven, grill or other source of high heat, or where it will be exposed to direct sunlight for prolonged periods of time.

WARNING: Ventilation: To ensure proper ventilation, keep any ventilation openings, in the appliance enclosure or in the built-in structure, clear of obstructions. Ensure adequate air circulation around the appliance to prevent overheating.

Level: Install the appliance level in order to ensure proper operation.

WARNING: Tipping Hazard: This appliance is heavy and may tip over. Use two or more people to move and install the appliance.

WARNING: Ventilation: Do not block ventilation openings. Insufficient airflow may cause overheating and not cooling.

Cleaning and Maintenance

Disconnect: Unplug the appliance before cleaning or servicing. Failure to do so can result in electric shock, injury or death. Do not connect or disconnect the plug when your hands are wet.

Flames: Do not let open flames or ignition sources enter the appliance.

Flammable/explosive substances: Never clean this appliance with flammable fluids. Do not store or use volatile, flammable or explosive propellants or liquids in or close to this or any other appliance. The fumes can create a fire hazard or explosion.

Solvents: Do not use solvent based cleaning agents or abrasives on the interior as these may damage or discolour the surfaces of the appliances.

WARNING! Do not use mechanical devices or other means to accelerate the defrosting process. Never use a sharp or metal instrument to remove frost or clean the appliance. Use a plastic scraper, if necessary.

Service: Do not attempt to repair, modify or replace any part of the appliance unless specifically recommended in this manual. Refer all other servicing to a qualified technician, or contact the after sales support line for advice on examination or repair of the appliance.

Responsible disposal

Note: At the end of its working life, do not throw this appliance out with your household rubbish. Electrical and electronic products contain substances that can have a detrimental effect on the environment and human health if disposed of inappropriately. Observe any local regulations regarding the disposal of electrical consumer goods and dispose of it appropriately for recycling and recovery of the refrigerant and blowing agent. Contact your municipal authorities for advice on recycling facilities in your area.

WARNING! This refrigeration appliance contains flammable refrigerants and insulation blowing gases, which must be removed before disposal. Contact your municipal authorities for any codes or regulations concerning the disposal of such materials.

Product Overview

Your Upright Freezer



Key:

1. Temperature Control Knob
2. Storage Drawers (×3)
3. Door
4. Adjustable Foot
5. Top Hinge Assembly
6. Bottom Hinge Assembly + Foot

The images in this user manual are for demonstration purposes only.
Your upright freezer may appear differently.

Getting Started

Unpacking

- **Packaging materials:** This appliance has been packaged to protect it against transportation damage. Remove all packaging materials from around and inside the appliance and keep the original packaging carton and materials in a safe place. It will help prevent any damage if the product needs to be transported in the future, and you can use it to store the appliance when it is not in use. In the event the carton is to be disposed of, please recycle all packaging materials where possible.
- **Suffocation:** Plastic wrapping can be a suffocation hazard for babies and young children, so ensure all packaging materials are out of their reach and disposed of safely.
- **Power cord:** Unwind the power cord to its full length and inspect it for damage. Do not use the appliance if it or its cord have been damaged or are not working properly. In case of damage, contact our after sales support line for advice on examination, repair or return of the damaged product.
- **Read the manual:** Read this manual to familiarise yourself with the appliance. Pay particular attention to the safety instructions on the previous pages.
- **Clean:** To remove any dust from transit and storage, clean the interior and exterior surfaces of the appliance with lukewarm water and a soft cloth. Dry thoroughly. **Important:** do not use harsh or abrasive detergents or powders as these will damage the finish.

Installation

- **Two person installation:** Use two or more people to move and install the appliance. Failure to do so can result in back or other injury.
- **Freestanding design:** This appliance is designed to be freestanding only, and should not be recessed or built-in.
- **Floor surface:** This appliance must be properly positioned on a dry, sturdy, level surface that is strong enough to support it when it is fully loaded.
- **Ambient temperature:** The ambient temperatures must correspond to the climate class (T) indicated on the rating plate of the appliance: 16°C – 38°C
- **Clearances:** Ensure that air can circulate freely around the back of the cabinet, which is necessary to cool the compressor and condenser. Allow at least 10cm clear space at the back and sides of the unit, and 30cm between the top and any surface above (i.e. a bench top). If you are installing your freezer next to a fixed wall, leave sufficient space on the hinge side to allow for the door to swing open.

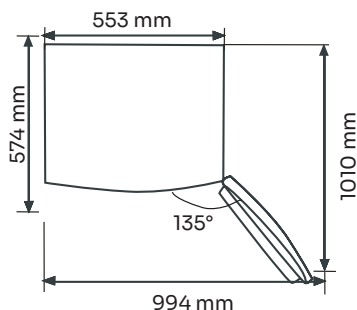

Installation (Continued)

Positioning

Do NOT install/use the appliance in the following locations/situations:

- In moist areas or areas of high humidity.
- In a recreational vehicle, or for use with an inverter.
- In direct sunlight, near heat sources, next to an open flame, cooking or heating appliance, or near any other source of high heat.
- Direct sunlight may affect the acrylic coating and heat sources may increase the unit's power consumption. For best energy efficiency install the appliance in the coolest area of the room.
- In an area with extreme cold ambient temperatures.
- In an area with excessive moisture and high humidity. Make sure it is protected from elements such as wind, rain, water spray or drips.
- In an area where petrol or other explosive and/or flammable liquids or fumes are used or stored. The fumes can create a fire hazard or explosion.

Electrical connection

- **WARNING!** It must be possible to disconnect the appliance from the mains power supply; the plug must therefore be easily accessible after installation.
- Before plugging in your new upright freezer, let it stand upright for at least 2 hours. This will allow the refrigerant gases to settle into the compressor and reduce the possibility of a malfunction in the cooling system.
- The appliance must be earthed. The plug of the power supply cord is equipped with a contact for this purpose. Do not under any circumstances cut or remove the third (earth) prong from the power cord. If the plug does not fit your outlet, consult a licensed electrician for advice to have the outlet changed.
- Plug the unit into a dedicated, properly earthed wall outlet. Ensure that your outlet voltage and circuit frequency correspond to the voltage stated on the rating label.
- Secure the upright freezer's supply cord behind the unit. Do not leave it exposed or dangling to prevent injury and accidental disconnection from the power supply.
- Adjust the temperature control as described below.
- When first starting up, and after a period out of use, allow the unit to cool down for at least 2–3 hours (4 hours if starting up during warm weather in summer) before placing food in the upright freezer.

Levelling Your Appliance

To level the appliance, use the levelling feet at the bottom.

- To raise the appliance, turn the feet clockwise.
- To lower the appliance, turn the feet counter-clockwise.
- Adjust the feet on the right and left sides until the appliance is horizontal and stable.

Reversing the door

Tools needed:

- Cross screwdriver
- Putty knife or thin-blade screwdriver
- 5/16" socket and ratchet
- Masking tape

1. Preparation:

- Power off the Upright Freezer.
- Remove all items from the unit.
- Securely tape the door closed to prevent it from swinging open during the process.

Using Your Upright Freezer

2. Disassembly:

- Unscrew and remove the top cover of the Upright Freezer.
- Unscrew and remove the upper hinge.
- Remove the door.
- Unscrew and remove the bottom hinge and levelling feet.

3. Reassembly on the Opposite Side:

- Move the levelling feet and bottom hinge to the opposite side of the Upright Freezer and secure them.
- Install the door stopper and axle sleeve on the opposite side of the door.
- Carefully place the door onto the bottom hinge.
- Attach the upper hinge to the opposite side and secure the door.
- Reinstall the top cover of the Upright Freezer.

Adjusting the Temperature

To adjust the temperature, use the control knob. Turn the knob to the right for colder temperatures and to the left for warmer temperatures. The dial is marked from 1 to 4, with 1 being the warmest setting and 4 being the coldest setting.

- For summer or if the room is too warm, set the thermostat to 4 for maximum cooling.
- For winter or if the room is too cold, set the thermostat to 1 for minimum cooling.
- For most situations, the recommended setting is in the middle range (between 2 and 3).

IMPORTANT: If the unit is unplugged, lost power, or turned off, you must wait 3 to 5 minutes before restarting the unit.

If you choose to change the thermostat setting, adjust the thermostat control by one numerical increment at a time. Allow several hours for temperature to stabilize between adjustments.

Your first use, you should set the thermostat to the maximum position of 6 for the first 24 to 48 hours, after which you can set it to the setting that best suites your needs.

Using for the First Time

When you install your appliance, set the thermostat knob to position 6 for the first 24–48 hours, after which you can set it to the level that best suites your needs. It is the best to wait 24 hours before adding food.

IMPORTANT: Once the unit has started, continuous operation is recommended. Please try and avoid turning the unit off and on as this may affect the service life.

Noise From Your Upright Freezer

- You may notice that your upright fridge makes some unusual noises from time to time. Most of these are perfectly normal, but you should be aware of them!
- These noises are caused by the circulation of the refrigerant liquid in the cooling system. This is not a fault and will not affect the performance of your unit and is common with all modern fridges.

Usage Tips

- Do not store food uncovered in the upright freezer. Always use good quality, freezer-proof packaging to maintain food quality. Remove air from packages of solid food and seal bags tightly before freezing.
- Keep portions small to ensure they are frozen (and subsequently defrosted) rapidly.
- Make sure that fresh, unfrozen food packages do not touch food that is already frozen, thus avoiding a temperature rise in the frozen food.
- When freezing food, do not push food together too much, leave some space for air to circulate around each item. Do not place packages directly against the back wall.
- When buying frozen food, only buy quantities that you can store straight away; use an insulated container for your shopping and when you get home, place the food in the chilling compartment immediately.
- When storing pre-packed, commercially frozen food, follow the food manufacturer's instructions for storing the food in a home fridge or freezer. Do not exceed any storage times listed on the packaging.
- Once you have opened a packet of frozen food, re-wrap it airtight to prevent surface evaporation which causes drying or freezer burn.
- Do not place carbonated liquids such as bottles of fizzy drink in the freezer as the container could explode under pressure and damage the chiller.
- Do not refreeze food once it has been defrosted.
- Frozen food which has thawed accidentally should either be used immediately or thrown away. Alternatively, if the food is uncooked and has not been completely defrosted, it may be cooked and then refrozen.
- **CAUTION!** Do not remove items from the chilling compartment if your hands are damp or wet as this could cause skin abrasions.

Energy Saving Tips

- The appliance should be placed in the coolest area of the room, away from heat producing appliances or heating ducts. Please avoid placement in direct sunlight.
- Let hot foods cool to room temperature before placing them in the appliance.
- Do not overload the appliance with unfrozen food as this may cause it to freeze slowly and risk food spoilage.
- Be sure to wrap foods properly and wipe containers dry before placing them in the appliance. This cuts down on frost building up inside in the unit.
- Please do not wrap items in aluminium foil, wax paper or paper towel. This materials interfere with cold air circulation, making the appliance less efficient.
- Organise and label food to reduce door openings and extended searches. Remove as many items as needed at one time, ensuring the unit is opened as few times as possible.

Maintenance and Cleaning

Defrosting

- For the most efficient operation and minimum energy consumption, defrost the freezer when the frost on the freezer walls is excessive or >5mm thick. To minimize disruption, choose a time when the stock of frozen food is low.

Important! Do not use boiling water because it may damage the plastic parts. In addition, never use a sharp or metallic instrument to remove frost as it may damage the cooling coils and will void the warranty. We recommend using a plastic scraper.

- Remove the frozen food from the freezer and place it in a cooler to protect the food.
- Unplug the upright freezer.
- During defrosting, the ice melts into the cabinet. You can also use a plastic scraper carefully.
- Clean the interior of the fridge and freezer and remove any water.
- Reset the thermostat to desired setting.
- Allow the cabinet to cool for one hour.
- Return food to the freezer.

Helpful Tip. Defrosting usually takes a few hours. Leaving the door open will help speed the process. Also, pouring warm water (not boiling) on the ice/frost will help speed melting. If you must use a scraper, please use caution: it is very easy to damage the freezer compartment and void your warranty.

Cleaning

WARNING

Before cleaning the appliance, make sure it is switched off and disconnected from the power supply. Failure to do so can result in electric shock or injury.

- Wash the inside surfaces and the interior accessories with a damp, warm cloth moistened in a water and baking soda solution. The solution should be about 2 tablespoons of baking soda to 1 litre of water. Rinse and wipe dry with a soft cloth.
- Clean the outside of the unit with a damp, well wrung out cloth, keeping the area of the controls dry. Keep the lid gasket (seal) clean.
- **Never use boiling water to accelerate defrosting as it may damage the plastic components.**
- After cleaning/defrosting, push the drain plug in.
- After everything is dry, place appliance back into service.
- Allow approximately 1–2 hours for the cabinet to cool down again (depending on the length of time the appliance was disconnected from the power).

WARNING

Never clean the unit with an abrasive, acid, oil or solvent based cleaning agent. Never use flammable fluids or sprays for cleaning as the fumes from these substances can create a fire hazard or Explosion.

Maintenance and Cleaning (Continued)

Maintenance and Cleaning Cont.

Service, repair and spare parts

Do not attempt to alter or modify this appliance in any way, or to repair or replace any part unless it is specifically recommended in this manual. All other servicing should be referred to a qualified technician. Contact our after sales support on 1300 11 43 57 for advice.

Our after sales support centre stocks a selection of spare parts for the Mykin 88L Upright freezer. To enquire about purchasing a part, call us on 1300 11 43 57 or email support@residentiagroup.com.au

Power Failure

Most power failures are corrected within a few hours and should not affect the temperature of your appliance if you minimise the number of times the door is opened. If the power is going to be off for a longer period of time, take proper steps to protect the contents.

FAQs and Troubleshooting

| Problem | Possible Cause | Possible Solution |
|---|---|--|
| The appliance does not operate. | <ul style="list-style-type: none"> ▪ The appliance is not plugged in. ▪ The appliance is turned off. ▪ The circuit breaker tripped or a blown fuse. | <ul style="list-style-type: none"> ▪ Plug in the appliance. ▪ Turn on power point. ▪ Reset circuit breaker/replace fuse. |
| The appliance is not cold enough. | <ul style="list-style-type: none"> ▪ Check the temperature control setting. ▪ The door is opened too often, or is kept open for too long; the door is not closed completely; hot food has been placed inside. ▪ The appliance has recently been disconnected for a period of time. | <ul style="list-style-type: none"> ▪ Reduce the temperature. ▪ Do not open door for 2+ hours; Check that the door is closed properly and for any obstructions preventing the door closing properly; Remove hot food and let it cool first before replacing it. ▪ Plug in the appliance. |
| The appliance has an odd odour. | <ul style="list-style-type: none"> ▪ Food may not be wrapped properly. ▪ Food may be rotten. ▪ The interior may not be clean. | <ul style="list-style-type: none"> ▪ Check that the food is wrapped tightly. ▪ Check for rotten food and remove. ▪ Clean the interior of the appliance. |
| The door will not close properly. | <ul style="list-style-type: none"> ▪ The appliance is not level. ▪ The gasket is dirty. ▪ Food is stacked too high. | <ul style="list-style-type: none"> ▪ Level the appliance. ▪ Clean gasket with warm water and a soft cloth. ▪ Re-position food so it does not obstruct. |
| The door is difficult to open. | <ul style="list-style-type: none"> ▪ A difference in pressure between the air inside and outside of the unit. | <ul style="list-style-type: none"> ▪ This is a normal phenomenon and cannot be avoided. |
| Moisture forms on the inside appliance walls. | <ul style="list-style-type: none"> ▪ Hot and humid weather increases the internal rate of frost build-up. ▪ The door is slightly open. ▪ The door is kept open too long, or is opened too frequently. | <ul style="list-style-type: none"> ▪ This is normal. ▪ Close the door. ▪ Open the door less often |
| Moisture forms on the outside of the appliance. | <ul style="list-style-type: none"> ▪ The door is slightly open, causing cold air from inside the appliance to meet warm, moist air from the outside. | <ul style="list-style-type: none"> ▪ Close the door or check for obstructions. |
| There are vibrations. | <ul style="list-style-type: none"> ▪ The appliance is not level. ▪ The floor is uneven or weak. ▪ The appliance is touching the wall. | <ul style="list-style-type: none"> ▪ Level the appliance. ▪ Be sure your floor can adequately support the appliance. ▪ Move the appliance away from the wall and check it is level. |

Specifications

| | |
|------------------------------|------------------------------|
| Model/s: | MUF88B, MUF88S, MUF88W |
| Product Dimensions: | W: 553mm, D: 574mm, H: 845mm |
| Weight: | 27.5kg |
| Net Capacity: | 88L |
| Energy Rating (MEPS): | 4 Stars |

Standards

This product complies with AS/NZS IEC 62552.1/2/3:2018 for electrical safety, and with EN 55014-1:2006+A1:2009 A2:2011 for electromagnetic compatibility.

Purchase Details

For your records, please record details of your purchase below and staple your receipt on the opposite page. Your serial number can be found on the rating plate of your Dishwasher.

STORE DETAILS

STORE NAME | _____

ADDRESS | _____

TELEPHONE | _____ PURCHASE DATE | _____

PRODUCT DETAILS

MODEL NO. | _____

SERIAL NO.* | _____

Attach your receipt to this page



Warranty

WARRANTY TERMS AND CONDITIONS UPRIGHT FREEZERS

This document sets out the terms and conditions of the product warranties for Residentia Group Appliances. It is an important document. Please keep it with your proof of purchase documents in a safe place for future reference should you require service for your Appliance.

1. IN THIS WARRANTY

- (a) 'acceptable quality' as referred to in clause 10 of this warranty has the same meaning referred to in the ACL;
- (b) 'ACL' means Trade Practices Amendment (Australian Consumer Law) Act (No.2) 2010;
- (c) 'Appliance' means any Residentia Group product purchased by you accompanied by this document;
- (d) 'ASR' means Residentia Group authorised service representative;
- (e) 'Residentia Group' means Residentia Group Pty Ltd of 165 Barkly Ave, Burnley VIC 3121, ACN 600 546 656 in respect of Appliances purchased in Australia;
- (f) 'major failure' as referred to in clause 10 of this warranty has the same meaning referred to in the ACL and includes a situation when an Appliance cannot be repaired or it is uneconomic for Residentia Group, at its discretion, to repair an Appliance during the Warranty Period;
- (g) 'Warranty Period' means:
 - (i) where the Appliance is used for personal, domestic or household use (i.e. normal single family use) as set out in the instruction manual, the Appliance is warranted against manufacturing defects for 24 months, following the date of original purchase of the Appliance;
- (h) 'you' means the purchaser of the Appliance not having purchased the Appliance for re-sale, and 'your' has a corresponding meaning.

2. This warranty only applies to Appliances purchased and used in Australia and is in addition to (and does not exclude, restrict, or modify in any way) any non-excludable statutory warranties in Australia.

3. During the Warranty Period Residentia Group or its ASR will, at no extra charge if your Appliance is readily accessible for service, without special equipment and subject to these terms and conditions, repair or replace any parts which it considers to be defective. Residentia Group or its ASR may use remanufactured parts to repair your Appliance. You agree that any replaced Appliances or parts become the property of Residentia Group. This warranty does not apply to light globes, batteries, filters, seals or similar perishable parts.
4. Parts and Appliances not supplied by Residentia Group are not covered by this warranty.
5. You will bear the cost of transportation, travel and delivery of the Appliance to and from Residentia Group or its ASR. If you reside outside of the service area, you will bear the cost of:
 - (a) travel of an authorised representative;
 - (b) transportation and delivery of the Appliance to and from Residentia Group or its ASR, in all instances, unless the Appliance is transported by Residentia Group or its ASR, the Appliance is transported at the owner's cost and risk while in transit to and from Residentia Group or its ASR.
6. Proof of purchase is required before you can make a claim under this warranty.

Warranty (Continued)

7. You may not make a claim under this warranty unless the defect claimed is due to faulty or defective parts or workmanship. Residentia Group is not liable in the following situations (which are not exhaustive):
- (a) the Appliance is damaged by:
 - (i) accident
 - (ii) misuse or abuse, including failure to properly maintain or service
 - (iii) normal wear and tear
 - (iv) power surges, electrical storm damage or incorrect power supply
 - (v) incomplete or improper installation
 - (vi) incorrect, improper or inappropriate operation
 - (vii) insect or vermin infestation
 - (viii) failure to comply with any additional instructions supplied with the Appliance;
 - (b) the Appliance is modified without authority from Residentia Group in writing;
 - (c) the Appliance's serial number or warranty seal has been removed or defaced;
 - (d) the Appliance was serviced or repaired by anyone other than Residentia Group, an authorised repairer or ASR.
8. This warranty, the contract to which it relates and the relationship between you and Residentia Group are governed by the law applicable where the Appliance was purchased.
9. To the extent permitted by law, Residentia Group excludes all warranties and liabilities (other than as contained in this document) including liability for any loss or damage whether direct or indirect arising from your purchase, use or non use of the Appliance.10. For Appliances and services provided by Residentia Group in Australia, the Appliances come with a guarantee by Residentia Group that cannot be excluded under the Australian Consumer Law. You are entitled to a replacement or refund for a major failure and for compensation for any other reasonably foreseeable loss or damage. You are also entitled to have the Appliance repaired or replaced if the Appliance fails to be of acceptable quality and the failure does not amount to a major failure. The benefits to you given by this warranty are in addition to your other rights and remedies under a law in relation to the Appliances or services to which the warranty relates.
11. At all times during the Warranty Period, Residentia Group shall, at its discretion, determine whether repair, replacement or refund will apply if an Appliance has a valid warranty claim applicable to it.
12. Missing parts are not covered by warranty. Residentia Group reserves the right to assess each request for missing parts in a case by case basis. Any parts that are not reported missing in the first week after purchase will not provide free of charge.
13. To enquire about claiming under this warranty, please follow these steps:
- (a) carefully check the operating instructions, user manual and the terms of this warranty;
 - (b) have the model and serial number of the Appliance available;
 - (c) have the proof of purchase (e.g. an invoice) available;
 - (d) telephone the numbers shown below.
14. You accept that if you make a warranty claim, Residentia Group and its ASR may exchange information in relation to you to enable Residentia Group to meet its obligations under this warranty.

IMPORTANT

Before calling for service, please ensure that the steps in point 13 have been followed.

CONTACT SERVICE

Service: 1300 11 HELP (4357)

The Australian Consumer Law requires the inclusion of the following statement with this warranty:

Our goods come with guarantees that cannot be excluded under the Australian Consumer Law. You are entitled to a replacement or refund for a major failure and for compensation for any other reasonably foreseeable loss or damage. You are also entitled to have the goods repaired or replaced if the goods fail to be of acceptable quality and the failure does not amount to a major failure.



E2447

myk1n

part of the family