

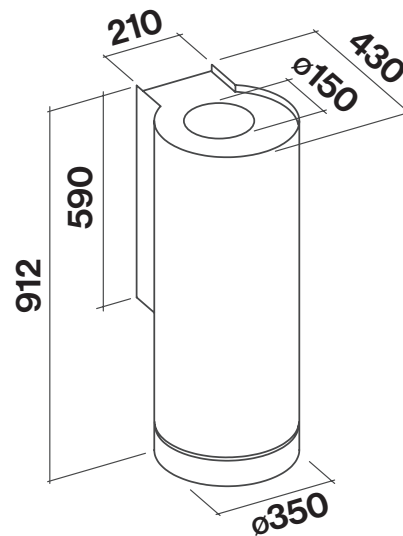

Product Features

<b>Motor Type</b>	On Board Motor
<b>Filtration Type</b>	Top Metallic Filter Charcoal Filter
<b>Controls</b>	Electronic Control
<b>Speed Settings</b>	3 Speed + Boost
<b>Ducting</b>	150mm circular outlet (Recirculating Function Available)
<b>Timer Functions</b>	15min Auto Shut-Off
<b>Other</b>	N/A

Dimensioned Drawings



Model Code	Hood Mounting	Size	Motor Output	Lighting	Finish
F5PR35B1 •	Wall	35cm	800 m <sup>3</sup> /hr	LED 3 x 1.2 W (2300 K)	Black
F5PR35W1	Wall	35cm	800 m <sup>3</sup> /hr	LED 3 x 1.2 W (2300 K)	White

Special Order •