

# Breville

*the Toast & Melt*

Instruction Booklet



BSG220/BSG520/BSG540

# CONGRATULATIONS

on the purchase of your new  
Breville Toast & Melt

## CONTENTS

- 4 Breville recommends safety first
- 6 Know your Breville Toast & Melt
- 8 Operating your Breville Toast & Melt
- 9 Toasted sandwiches
- 10 Open sandwich melts
- 12 Hints for best results
- 14 Care, cleaning & storage
- 16 Recipes
  - Savoury (p17)
  - Sweet (p25)

At Breville we are very safety conscious. We design and manufacture consumer products with the safety of you, our valued customer, foremost in mind. In addition we ask that you exercise a degree of care when using any electrical appliance and adhere to the following precautions.

## IMPORTANT SAFEGUARDS

### READ ALL INSTRUCTIONS BEFORE USE AND SAVE FOR FUTURE REFERENCE

- Carefully read all instructions before operation and save for future reference.
- Remove any packaging material and promotional stickers before using the sandwich press for the first time.
- To eliminate a choking hazard for young children, remove and safely discard the protective cover fitted to the power plug of this appliance.
- Do not place the sandwich press near the edge of a bench or table during operation. Ensure that the surface is level, clean and free of water.
- Keep the sandwich press clear of walls, curtains and other heat or steam sensitive materials.
- Do not place the sandwich press on or near a hot gas or electric burner, or where it could touch a heated oven. Use the sandwich press well away from walls.
- Provide adequate space above and on all sides for air circulation around the sandwich press.
- Do not place the sandwich press on any surface that may be affected by heat. The use of a heat resistant mat is recommended on these surfaces.
- Do not use on a sink drain board.
- Always use the sandwich press on a dry, level surface.
- Do not touch hot surfaces. Use the handles to lift and open the top plate. Take care when using the Adjustable Grilling Height Control.
- Do not leave the sandwich press unattended when in use.
- Do not place anything on top of the sandwich press when the lid is closed, when in use and when stored.
- Always switch the sandwich press off at the power outlet, then unplug the power cord and to allow to cool, if appliance is not in use, before cleaning, before attempting to move the appliance, disassembling, assembling and when storing the appliance.
- Do not use harsh abrasives, caustic cleaners or oven cleaners when cleaning the sandwich press.
- Keep the exterior housing and the non-stick cooking plates clean. Follow the cleaning instructions provided in this book. Refer to Care, Cleaning and Storage (Page 11).
- This appliance is not intended to be operated by means of an external timer or separate remote control system.

## IMPORTANT SAFEGUARDS FOR ALL ELECTRICAL APPLIANCES

- Fully unwind the power cord before use.
- Do not let the power cord hang over the edge of a bench or table, touch hot surfaces or become knotted.
- To protect against electric shock do not immerse the power cord, power plug or appliance in water or any other liquid.
- The appliance is not intended for use by persons (including children) with reduced physical, sensory or mental capabilities, or lack of experience and knowledge, unless they have been given supervision or instruction concerning use of the appliance by a person responsible for their safety.
- Children should be supervised to ensure that they do not play with the appliance.
- It is recommended to regularly inspect the appliance. To avoid a hazard do not use the appliance if power cord, power plug or appliance becomes damaged in any way. Return the entire appliance to the nearest authorised Breville Service Centre for examination and/or repair.
- Any maintenance other than cleaning should be performed at an authorised Breville Service Centre.
- This appliance is for household use only. Do not use this appliance for anything other than its intended use. Do not use in moving vehicles or boats. Do not use outdoors. Misuse may cause injury.
- The installation of a residual current device (safety switch) is recommended to provide additional safety protection when using electrical appliances. It is advisable that a safety switch with a rated residual operating current not exceeding 30mA be installed in the electrical circuit supplying the appliance. See your electrician for professional advice.



## IMPORTANT

*Fully unwind the power cord from the cord storage facility before use.*

## SAVE THESE INSTRUCTIONS

# KNOW

your Breville Toast & Melt

## KNOW YOUR BREVILLE TOAST & MELT

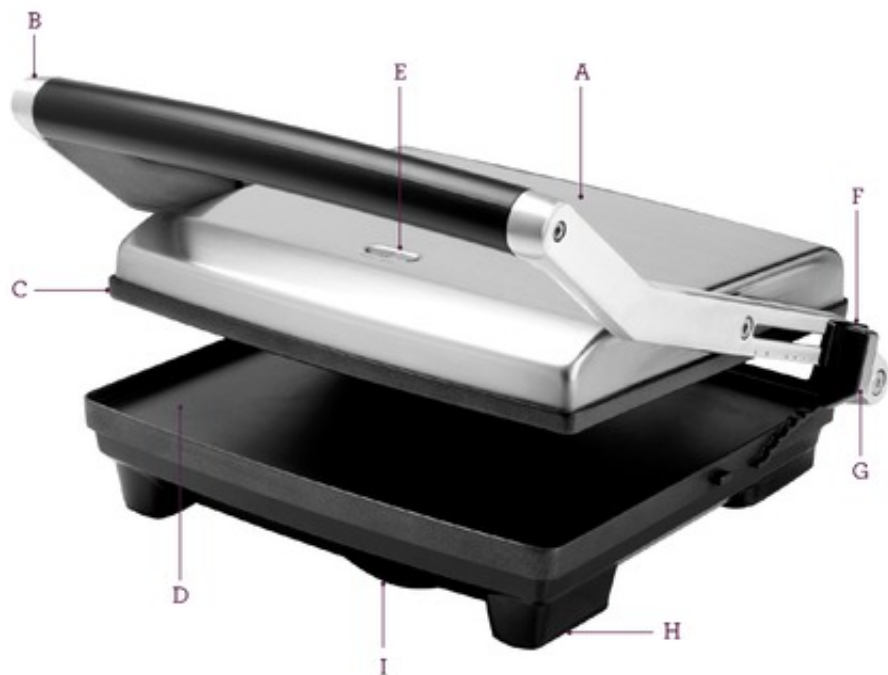

- A. **2200W of power (BSG540) 2000W of power (BSG520 & BSG220)** for fast heat up and quick toasting.
- B. **Heavy duty die-cast arms** for durability and strength.
- C. **Floating top plate** automatically adjusts to thick or thin sandwiches.
- D. **Flat non-stick cooking plates** for extra crispy toasted results.
- E. **'Power' and 'Ready' lights** indicate when the sandwich press is heating or ready to use.
- F. **Adjustable height control clip** with 4 settings for making open sandwich melts, toasted sandwiches and everything in between.
- G. **Safety locking storage clip** to lock plates closed for upright storage.
- H. **Non-slip feet**
- I. **Convenient cord wrap in base**

# OPERATING

your Breville Toast & Melt



## OPERATING YOUR BREVILLE TOAST & MELT

### BEFORE FIRST USE

Remove any promotional materials and packaging materials before use. Check that the cooking plates are clean and free of dust. If necessary, wipe over with a damp cloth.

When using the sandwich press for the first time you may notice a fine smoke haze. This is caused by the heating of some of the components. There is no need for concern.

### TOASTED SANDWICHES

1. Insert the power plug into a 230V or 240V power outlet and then turn the power ON. The red 'POWER' light will illuminate.
2. Allow the sandwich press to pre-heat with the top cooking plate in the closed position until the green 'READY' light illuminates.
3. During this time, prepare the sandwich. When the sandwich press has pre-heated, place the sandwich onto the bottom cooking plate. Always place sandwiches towards the rear of the bottom cooking plate.
4. Close the top cooking plate. The top cooking plate has a floating hinge that is designed to evenly press down on the sandwich (see Fig 1).



Fig. 1

5. Toasting should take approximately 5-8 minutes. Exact toasting time will be a matter of taste. It will also depend on the type of bread and type of filling used.
6. When the sandwich is cooked, use the handle to open the sandwich press and raise the top cooking plate. Remove sandwich with the help of a plastic or wooden spatula. Never use metal tongs or a knife as these can cause damage to the non-stick coating.

#### NOTE

Always allow the sandwich press to pre-heat until the green 'READY' light illuminates.

#### NOTE

The safety locking storage clip should not be used to clamp down the top cooking plate when the sandwiches are in the sandwich press. The weight of the top cooking plate will gradually press down the sandwich during the cooking process.

#### NOTE

When using the sandwich press for the first time you may notice a fine smoke haze. This is caused by the heating of some of the components. There is no need for concern.

### CAUTION

**HOT SURFACE** - The temperature of accessible surfaces may be high when the appliance is operating.

Fully unwind the cord from the cord storage facility before use.

## OPERATING YOUR BREVILLE TOAST & MELT

Your sandwich press features an Adjustable Height Control feature which allows you to fix the top plate to a range of positions above the bottom plate. This allows your sandwich press to be used as an open toaster ideal for toasting open sandwich melts. It can also be used for toasting sandwiches where you don't need to apply the weight of the top plate.

### OPEN SANDWICH MELTS

1. Allow the sandwich press to pre-heat until the green 'READY' light illuminates.
2. Place sandwich to be melted on bottom plate.
3. Move the Adjustable Height Control clip on the right hand side of the sandwich press to the desired height (see Fig 2).
4. Slowly lower the top plate until it rests on the Adjustable Height Control clip.
5. The top plate will radiate the desired heat to melt ingredients such as cheese.
6. Toasting melts should take approximately 3-4 minutes. However exact toasting time will be a matter of taste. It will also depend on the height of the top plate.



Fig. 2



### Adjustable Height Control

Toasts or melts any bread thickness in minutes.



Fig. 3

### NOTE

The Adjustable Height Control can be moved to accommodate thick or thin melts by sliding the clip forwards or backwards along the arm.



# HINTS FOR BEST RESULTS

from your Breville Toast & Melt

## HINTS FOR BEST RESULTS

### BREAD

Most types of bread can be used; white, wholemeal, kibbled wheat, wholegrain, raisin loaf and so on. The sandwich press is ideal for toasting foccacia, Turkish bread, baguettes as well as bread rolls. Raisin bread, brioche or other sweet breads which contain a high sugar content will tend to brown quicker.

### FILLINGS

Try to use canned or pre-cooked fruit as fresh fruit may give off excessive juices when heated. Be careful when biting into sandwiches containing fillings such as cheese and tomato or jam as they retain heat and can burn if eaten too quickly.

### TOASTING BREAD

The unique flat plate design makes the sandwich press ideal for toasting plain breads, and Turkish bread, without any fillings or spreads. Try toasting Turkish Bread with jams for a great alternative to standard breads at breakfast.

### FAT FREE SNACKS

Due to the non-stick flat plate design, it is not necessary to use any butter or margarine on the outside of your toasted snacks.

# CARE, CLEANING & STORAGE

for your Breville Toast & Melt

## CARE, CLEANING & STORAGE

Before cleaning, switch the power off at the power outlet and then remove the power plug. Allow your sandwich press to cool before cleaning. The appliance is easier to clean when slightly warm.

Always clean your sandwich press after each use to prevent a build up of baked-on foods.

Wipe cooking plates with a soft cloth. If cooked on food is not removed by this method reheat the unit for 1-2 minutes, then brush with a little oil or melted butter. Allow to stand for five minutes then wipe with a damp cloth.

### NOTE

The cooking plates are coated with a non-stick surface, do not use abrasives.

### NOTE

Do not use spray-on non-stick coatings as this will affect the performance of the non-stick surface on the cooking plates.

## STORAGE

To store your sandwich press:

1. Switch off at power outlet and unplug power cord from the wall.
2. Allow the sandwich press to fully cool.
3. Slide the Adjustable Height Control towards the front handle to the 'LOCK' position so that the top and bottom cooking plates are locked together (see Fig 4).



Fig. 4

4. Wrap the power cord in the cord storage area below the appliance (see Fig 5).
5. Store on a flat, dry, level surface.



Fig.5

### NOTE

The storage clip should not be used to clamp down the top plate when sandwiches are in the sandwich press.

## WARNING

*Do not immerse any part of the sandwich press in water or any other liquid.*

# RECIPES



## SAVOURY TOASTED SANDWICHES

### OMELETTE FOCACCIA WITH ROASTED CAPSICUM & MUSHROOM

Serves 2

#### INGREDIENTS

3 bacon rashers, thinly sliced  
1 Tablespoon extra virgin olive oil  
100g button mushrooms, sliced  
½ cup shallots, thinly sliced  
Freshly ground black pepper  
3 x 60g eggs, lightly beaten  
1 Tablespoon freshly chopped herbs  
¼ cup thinly sliced roasted capsicum  
1 large focaccia, halved  
125g sliced Swiss cheese  
Salad greens, optional

#### METHOD

1. Pre-heat sandwich press until the green 'READY' light illuminates.
2. Meanwhile, fry bacon in a non-stick frypan until crisp. Remove from pan and set aside. Sauté mushrooms and shallots in frypan until any liquid has evaporated. Remove from heat.
3. Beat eggs lightly adding pepper and herbs. Pour mixture over mushrooms in pan. Return to medium heat and cook until eggs are set but soft in the centre, approximately 3-5 minutes.
4. Remove omelette from frypan and roughly chop.
5. Cut focaccia in half to form a sandwich. Fill focaccias with omelette, capsicum, cheese and bacon.
6. Cook focaccia until golden, crisp and heated through, approximately 8 minutes
7. Serve with salad greens.

### CHAR GRILLED CHICKEN LAVOSH WITH MANGO & PINENUT MAYONNAISE

Serves 2-3

#### INGREDIENTS

¼ cup mayonnaise  
¼ Tablespoon chilli salsa  
1 teaspoons grated lime rind  
¼ Tablespoon lime juice  
125g canned mango pieces, drained  
1½ Tablespoon toasted pinenuts  
1 char-grilled chicken breast, sliced thinly  
2 sheets lavosh bread  
1 avocado, sliced  
Salad greens, optional

#### METHOD

1. Pre-heat sandwich press until the green 'READY' light illuminates.
2. Combine mayonnaise, salsa, rind, juice, mango, pinenuts and chicken.
3. Spread chicken mixture over each lavosh. Top with avocado and roll tightly.
4. Cook lavosh rolls until golden, crisp and heated through, approximately 8 minutes.
5. Serve sliced on an angle with salad greens.

## SAVOURY TOASTED SANDWICHES

### TUNA, BRIE & ARTICHOKE ROLLS

Serves 2

#### INGREDIENTS

2 large crusty round rolls  
100g black olive paste  
200g can tuna, drained  
6 marinated baby artichokes  
125g Brie cheese, thinly sliced

#### METHOD

1. Pre-heat sandwich press until the green 'READY' light illuminates.
2. Cut rolls in half and spread with olive paste. Fill with tuna, artichokes and cheese.
3. Cook until golden, crisp and heated through, approximately 8 minutes.

### MEXICAN TORTILLAS WITH CHORIZO & SOUR CREAM

Serves 2-3

#### INGREDIENTS

125g Mexican salsa  
¼ cup red kidney beans  
1 Tablespoon freshly snipped garlic chives  
100g finely chopped chorizo sausage  
8 tortilla rounds (unfried variety)  
100g tzatziki dip  
100g avocado dip  
125g mozzarella cheese, grated  
Sour cream, for serving  
Salad greens, optional

#### METHOD

1. Pre-heat sandwich press until the green 'READY' light illuminates.
2. Combine salsa, beans, chives and sausage. Spoon mixture over 4 tortillas. Top with alternating layers of tzatziki, avocado and cheese, then remaining 4 tortillas to make 4 sandwiches. Be careful not to overfill.
3. Cook tortillas until golden, crisp and heated through, approximately 8 minutes.
4. Serve with sour cream and salad greens.

### ROAST BEEF PITA WITH EGGPLANT & MUSTARD

Serves 2-3

#### INGREDIENTS

- 2 round Pita bread
- 70g cream cheese
- 3 teaspoons seeded mustard
- ½ Tablespoon lemon juice
- ⅓ cup grated canned beetroot, drained
- 100g shaved rare roast beef
- 70g marinated roasted eggplant

#### METHOD

1. Pre-heat sandwich press until the green 'READY' light illuminates.
2. Combine cream cheese, mustard and lemon juice. Spread each Pita bread with cream cheese mixture. Top with beetroot, roast beef and eggplant. Roll tightly.
3. Cook Pita bread until golden, crisp and heated through, approximately 10 minutes. Serve sliced.

### SPICY LAMB PITA WITH MINT & TOMATO

Serves 2-3

#### INGREDIENTS

- 1 Tablespoon oil
- 125g ground lamb mince
- 2 Tablespoons finely chopped onion
- ½ cup diced tomato
- 1 Tablespoon freshly chopped mint
- ¼ teaspoon ground coriander
- Pinch ground ginger
- ½ teaspoon ground cumin
- ¼ teaspoon turmeric
- Salt and freshly ground black pepper, to taste
- 3 pita breads
- 3 slices Swiss cheese
- Tzatziki dip, for serving

#### METHOD

1. Pre-heat sandwich press until the green 'READY' light illuminates.
2. Heat oil in a non-stick frypan, sauté lamb mince, onions, tomato, mint, spices and seasonings until browned and cooked. Drain.
3. Split pitas open to form pockets. Fill with lamb mixture and insert a cheese slice into each pocket.
4. Cook pitas until golden, crisp and heated through, approximately 10 minutes.
5. Serve with tzatziki dip.

## SAVOURY TOASTED SANDWICHES

### WARM CAESAR TURKISH

Serves 2

#### INGREDIENTS

3 bacon rashers, thinly sliced  
2 round Turkish breads  
1 char grilled chicken breast fillet, thinly sliced  
1 hard boiled egg, peeled and sliced  
1/4 cup prepared garlic croutons  
30g baby spinach leaves  
60g freshly grated Parmesan cheese  
Caesar salad dressing, for serving

#### METHOD

1. Pre-heat sandwich press until the green 'READY' light illuminates.
2. Meanwhile heat a non-stick frypan and fry bacon until crispy. Cut Turkish bread in half to form a sandwich. Fill with bacon, chicken, eggs, croutons, spinach and cheese.
3. Cook Turkish bread until golden, crisp and cooked through, approximately 6 minutes.
4. Serve drizzled with Caesar salad dressing.

### MEDITERRANEAN LAYERED COB ROLLS

Serves 2-3

#### INGREDIENTS

2 twist or cob bread rolls  
2 Tablespoons pesto  
100g marinated roasted eggplant  
125g marinated roasted red capsicum  
60g char-grilled sliced sweet potato  
100g marinated semi-dried tomatoes, drained  
60g mushrooms, sliced  
100g sliced Swiss cheese

#### METHOD

1. Pre-heat sandwich press until the green 'READY' light illuminates.
2. Cut bread rolls in half and spread with pesto. Fill with eggplant, capsicum, sweet potato, dried tomato, mushrooms and cheese.
3. Cook bread rolls until golden, crisp and heated through, approximately 8 minutes.

## SAVOURY TOASTED SANDWICHES

### ANTIPASTO RYE WITH HOMMUS

Serves 2-3

#### INGREDIENTS

- 4 slices rye bread
- ½ Tablespoon extra virgin olive oil
- 1 Tablespoon sun-dried tomato paste
- 60g hommus
- 4 stuffed vine leaves
- 200g artichoke hearts, drained and sliced
- 4 slices Swiss cheese

#### METHOD

1. Pre-heat sandwich press until the green 'READY' light illuminates.
2. Combine oil tomato paste. Spread rye bread with tomato mixture then hommus. Fill with vine leaves, artichokes and cheese to make 2 sandwiches.
3. Cook until golden, crisp and heated through, approximately 8 minutes.
4. Serve cut in half.

### GORGONZOLA PANINI WITH SPINACH

Serves 2

#### INGREDIENTS

- 30g herb and garlic butter
- 4 slices crusty country-style bread
- 50g English spinach leaves
- 60g Gorgonzola cheese, crumbled
- 60g marinated roasted capsicum

#### METHOD

1. Pre-heat sandwich press until the green 'READY' light illuminates.
2. Spread herb and garlic butter over bread slices and fill with spinach, cheese and capsicum.
3. Cook until golden, crisp and heated through approximately 6 minutes.
4. Serve cut in half.

### GOAT'S CHEESE & ROASTED PEPPER FOCACCIA

Serves 2

#### INGREDIENTS

- 1 large round focaccia
- 90g softened goat's cheese
- ½ Tablespoon roughly chopped Italian parsley
- ½ Tablespoon roughly chopped basil
- 1 clove garlic, thinly sliced
- 1 Tablespoon drained capers
- 1 Tablespoon lemon juice
- ½ Tablespoon sweet Thai chilli sauce
- 60g marinated roasted zucchini
- 50g semi dried tomatoes

#### METHOD

1. Pre-heat sandwich press until the green 'READY' light illuminates.
2. Cut focaccia in half to form a sandwich. Combine goat's cheese, parsley, basil, garlic, capers, lemon juice and chilli sauce. Spread focaccia with goat's cheese mixture. Fill with zucchini and tomatoes.
3. Cook focaccias until golden, crisp and heated through, approximately 8 minutes.

### PROSCIUTTO BAGUETTE WITH BOCCONCINI

Serves 2

#### INGREDIENTS

- 2 small-medium baguette rolls
- 80g Italian prosciutto, thinly sliced
- 75g bocconcini cheese, thinly sliced
- 4 basil leaves
- Freshly ground black pepper
- 1 Tablespoon extra virgin olive oil

#### METHOD

1. Pre-heat sandwich press until the green 'READY' light illuminates.
2. Cut baguette in half. Fill with layers of prosciutto, cheese and basil. Season to taste and drizzle with oil.
3. Cook baguettes until golden, crisp and heated through, approximately 6-8 minutes.
4. Serve cut in half.

## SAVOURY TOASTED SANDWICHES

### CHAR-GRILLED CHICKEN AND SALSA VERDE CIABATTA

Serves 2

#### INGREDIENTS

- 1 char-grilled chicken breast fillet, sliced
- 1 clove garlic, thinly sliced
- ½ cup chopped parsley
- 1 Tablespoon finely chopped sage
- ¼ cup stuffed pimento green olives, chopped
- 1 Tablespoon drained capers
- 1 Tablespoon extra virgin olive oil
- ½ teaspoon freshly grated lime rind
- ½ Tablespoon lemon juice
- 4 large slices Ciabatta bread
- 4 large slices Swiss cheese

#### METHOD

1. Pre-heat sandwich press until the green 'READY' light illuminates.
2. Combine chicken, garlic, parsley, sage, olives, capers, oil, rind and juice. Fill bread with chicken mixture and sliced cheese to make 2 sandwiches.
3. Cook until golden, crisp and heated through, approximately 8-10 minutes.

### PRAWN AND WATERCRESS WHOLEGRAIN TOASTIE

Serves 2

#### INGREDIENTS

- 4 slices wholegrain bread
- 70g cream cheese, softened
- 60g herb & garlic butter
- 75g watercress
- 400g medium cooked king prawns, peeled and de-veined

#### METHOD

1. Pre-heat sandwich press until the green 'READY' light illuminates.
2. Spread bread with combined cream cheese and garlic butter. Fill with watercress and prawns to make 2 sandwiches.
3. Cook until golden, crisp and heated through, approximately 8 minutes.



## SAVOURY TOASTED SANDWICHES

### CRISPY SWORDFISH FOCACCIA WITH SPINACH & MAYO

Serves 2

#### INGREDIENTS

- 250g fresh swordfish fillets thinly sliced
- 1½ Tablespoons extra virgin olive oil
- 2 Tablespoons freshly chopped herbs (basil, garlic chives, thyme, dill)
- ½ teaspoon paprika
- Salt and freshly ground black pepper, to taste
- 1 large focaccia
- 2 Tablespoons mayonnaise
- 4 tomato slices
- ½ Tablespoon drained capers
- 6 baby English spinach leaves

#### METHOD

1. Pre-heat sandwich press until the green 'READY' light illuminates.
2. Brush fish fillets with half the olive oil. Coat fillets with combined herbs, paprika and seasonings.
3. Heat remaining oil in a frypan. Fry fish until golden. Remove and drain.
4. Cut focaccia in half to form a sandwich and spread mayonnaise. Fill with fish, tomato, capers and spinach.
5. Cook focaccias until golden, crisp, and heated through, approximately 5 minutes.

#### NOTE

Large focaccia may need to be cut in half to fit into BSG220 and BSG520 2 Slice Sandwich Press's.

### ITALIAN FONTINA TOASTIE

Serves 2

#### INGREDIENTS

- 4 slices white bread
- 100g Italian fontina cheese, sliced
- 100g marinated roasted red capsicums
- 100g sliced marinated mushrooms
- Freshly ground black pepper, to taste

#### METHOD

1. Pre-heat sandwich press until the green 'READY' light illuminates.
2. Fill bread with layers of cheese, capsicum and mushrooms season with pepper make into 2 sandwiches.
3. Cook until golden, crisp and heated through, approximately 6-8 minutes.

#### NOTE

Fontina cheese may be substituted with Parmesan or Romano cheese.



## SWEET TOASTED SANDWICHES

### CHOCOLATE CREAM CHEESE TOASTIE

Serves 2

#### INGREDIENTS

80g cream cheese, softened  
4 slices textured Country style bread  
250g bittersweet chocolate, coarsely grated  
Vanilla ice-cream, for serving

#### METHOD

1. Pre-heat sandwich press until the green 'READY' light illuminates.
2. Spread cream cheese over bread slices and sprinkle with grated chocolate. Sandwich together.
3. Cook until golden, crisp and heated through, approximately 6 minutes.
4. Serve with ice-cream.

### CRISPY BRIOCHE WITH BERRIES AND ICE-CREAM

Serves 2

#### INGREDIENTS

½ punnet strawberries, hulled  
½ punnet blueberries  
½ punnet raspberries  
¼ cup port  
1 loaf brioche  
Vanilla ice-cream, for serving  
Icing sugar, for serving

#### METHOD

1. Pre-heat sandwich press until the green 'READY' light illuminates.
2. Puree berries and port until smooth. Set aside. Cut 4 slices from brioche and cook until toasted, approximately 5 minutes.
3. Arrange toasted brioche on 2 large, white plates. Top with ice-cream and drizzle with berry sauce.
4. Serve immediately, dust with icing sugar.

## SWEET TOASTED SANDWICHES

### BERRY & MASCARPONE TOASTIE

Serves 2

#### INGREDIENTS

- 100g Mascarpone cheese
- 4 slices Country style bread
- ½ punnet strawberries, hulled and sliced
- ½ punnet raspberries
- 1 Tablespoon honey

#### METHOD

1. Pre-heat sandwich press until the green 'READY' light illuminates.
2. Spread cheese over bread slices. Fill with berries and drizzle with honey to make 2 sandwiches.
3. Cook until golden, crisp and heated through, approximately 8 minutes.

### SWEET NECTARINE & CINNAMON TOASTIE

Serves 2

#### INGREDIENTS

- 40g unsalted butter, softened
- 4 slices soy and linseed grain bread
- 2 nectarines, peeled and sliced
- 1 teaspoon ground cinnamon
- 2 Tablespoons caster sugar

#### METHOD

1. Pre-heat sandwich press until the green 'READY' light illuminates.
2. Spread butter over bread slices. Fill with sliced nectarine and sprinkle with combined cinnamon and sugar to make 2 sandwiches.
3. Cook until golden, crisp and heated through, approximately 8 minutes.

## SWEET TOASTED SANDWICHES

### FIG & RICOTTA FOCACCIA WITH FRESH MINT

Serves 2

#### INGREDIENTS

- 2 small plain rounds of focaccia
- 80g fresh ricotta cheese
- 3 fresh figs, thinly sliced
- 6 small fresh mint leaves
- 1 Tablespoon caster sugar

#### METHOD

1. Pre-heat sandwich press until the green 'READY' light illuminates.
2. Cut focaccias in half to form a sandwich. Spread with ricotta cheese. Fill with figs, mint leaves and sprinkling of caster sugar.
3. Cook until golden, crisp and heated through, approximately 8 minutes.

# Breville

## Breville Customer Service Centre

### Australian Customers

**Mail:** PO Box 22  
Botany NSW 2019  
AUSTRALIA

**Phone:** 1300 139 798

**Fax:** (02) 9384 9601

**Email:** Customer Service:  
askus@breville.com.au

### New Zealand Customers

**Mail:** Private Bag 94411  
Botany Manukau 2163  
Auckland NEW ZEALAND

**Phone:** 0800 273 845

**Fax:** 0800 288 513

**Email:** Customer Service:  
askus@breville.com.au

[www.breville.com.au](http://www.breville.com.au)

Breville is a registered trademark of Breville Pty. Ltd. A.B.N. 98 000 092 928.  
Copyright Breville Pty. Ltd. 2010.

Due to continued product improvement, the products illustrated/photographed  
in this booklet may vary slightly from the actual product.

**Model BSG220/BSG520/BSG540 Issue - B10**