

---

EC9255

# La Specialista

ARTE EVO

COFFEE MAKER  
Instruction for use



---

**DeLonghi**

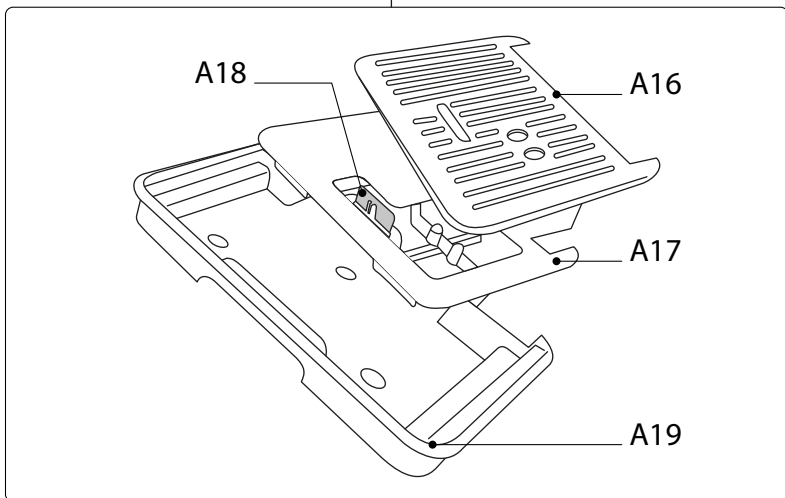
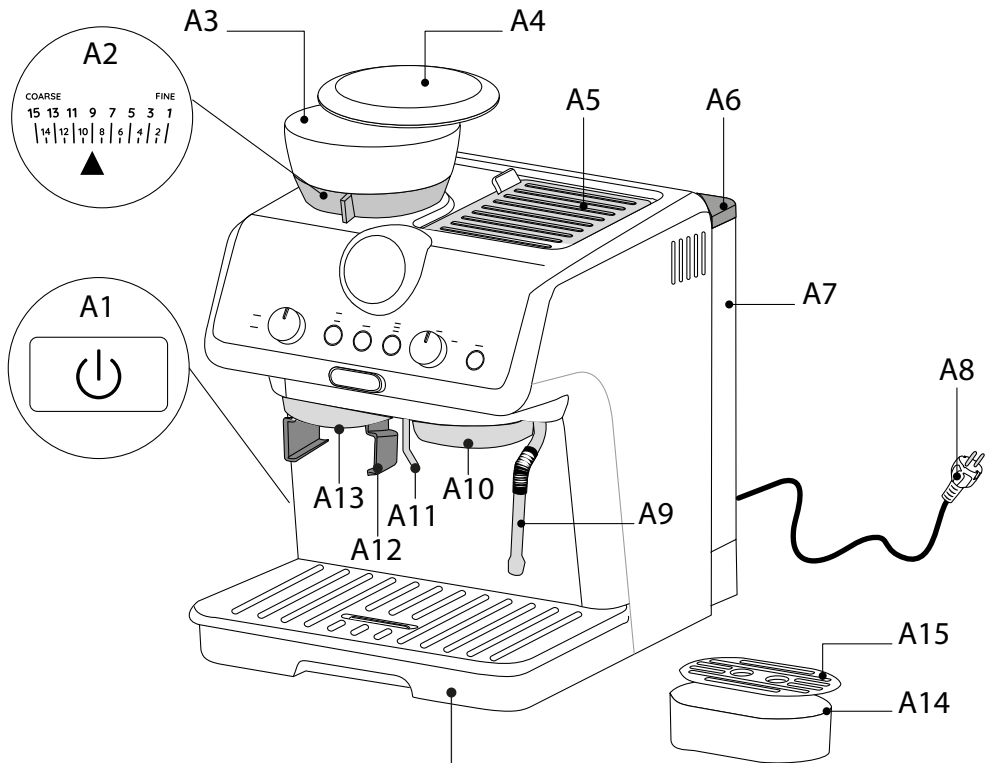

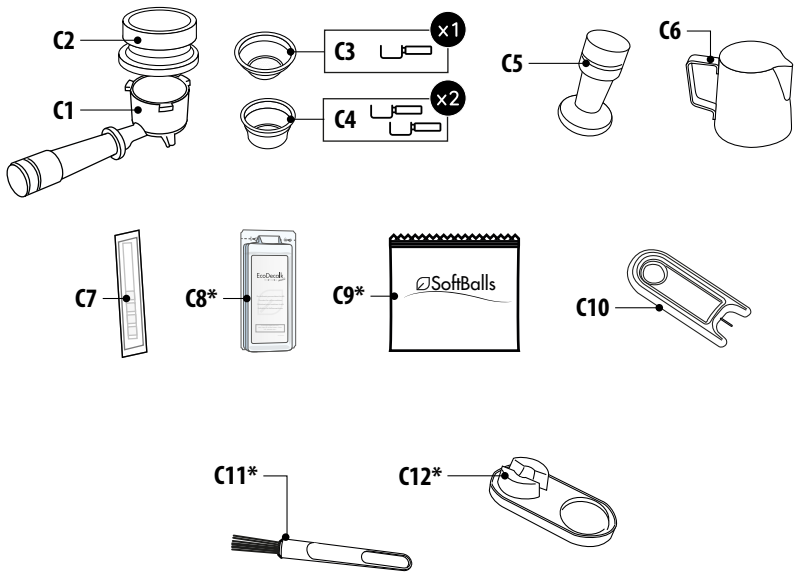
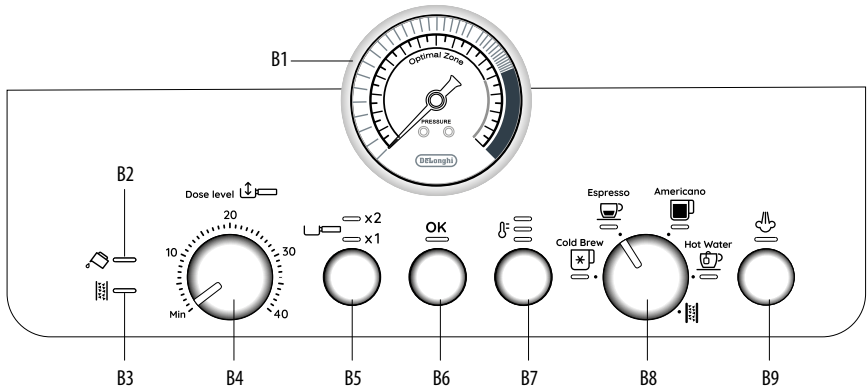

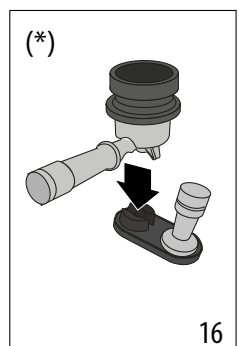
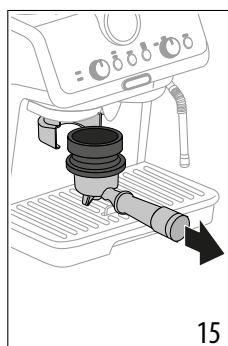
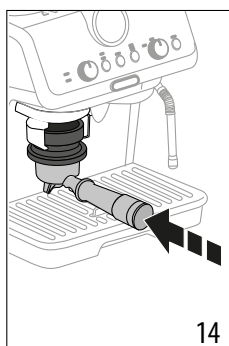
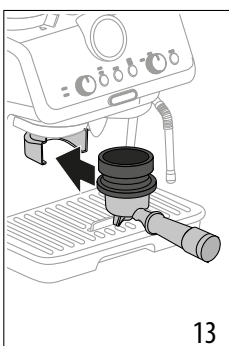
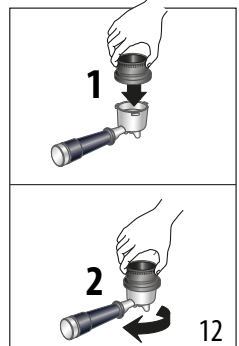
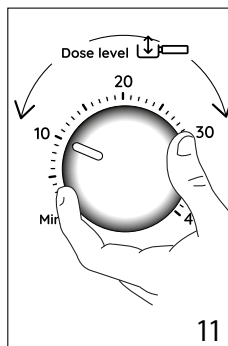
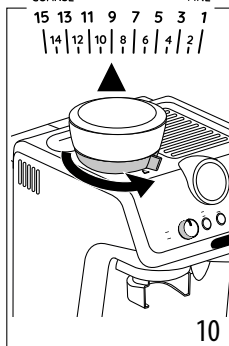
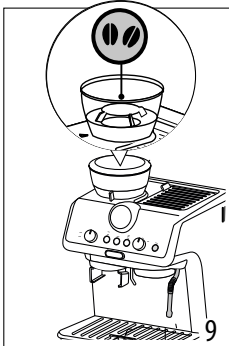
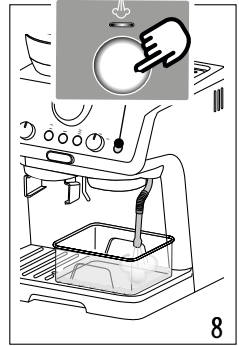
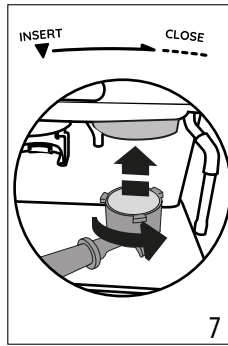
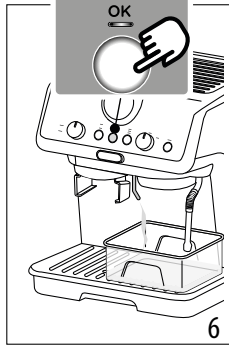
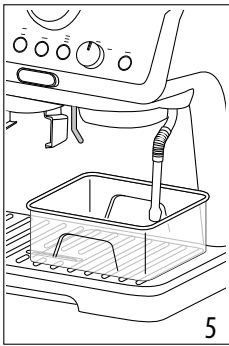
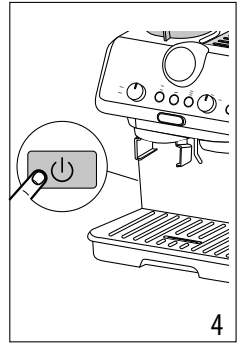
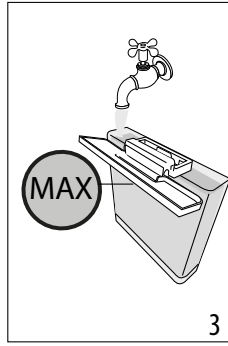
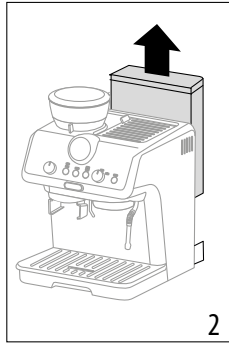
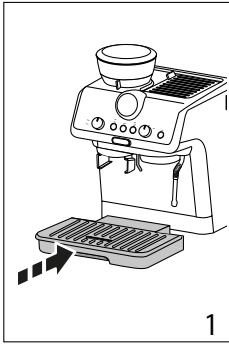

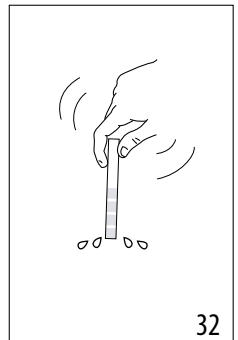
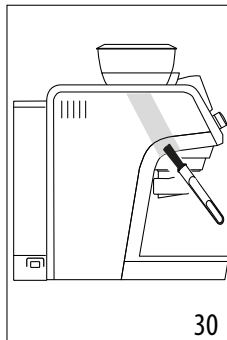
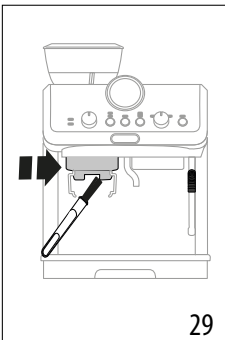
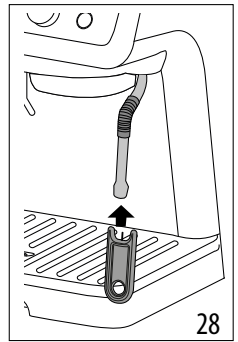
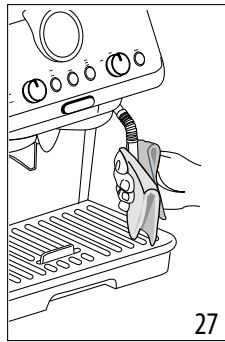
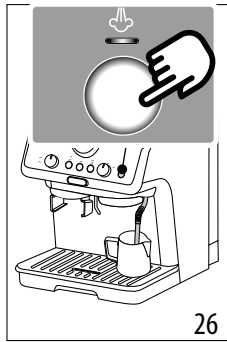
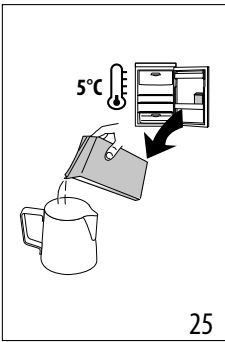
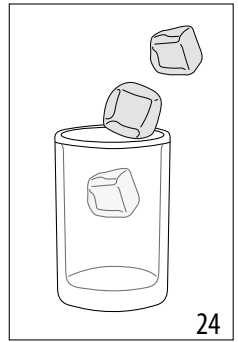
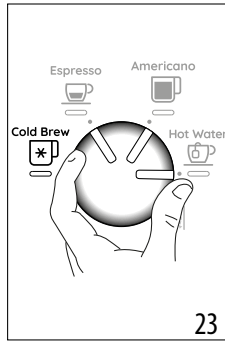
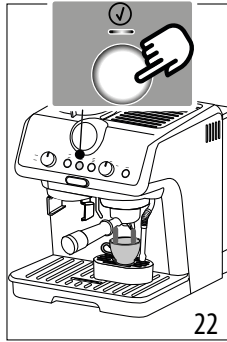
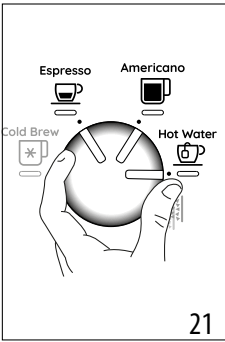
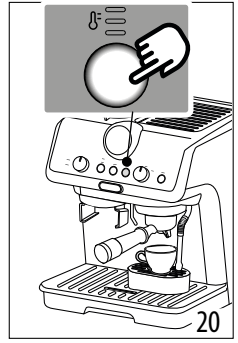
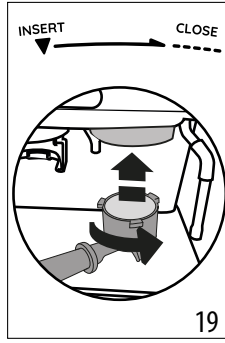
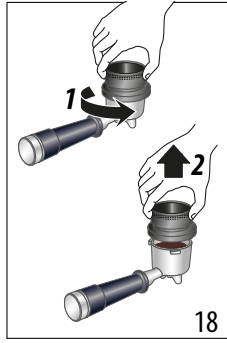
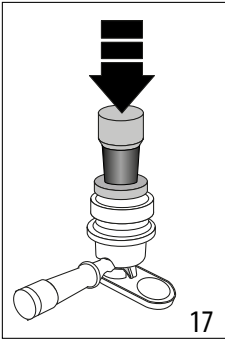

Before using the appliance, always read the safety warnings.

## 1. DESCRIPTION

### 1.1 Description of appliance - A

- A1. Main switch (ON/OFF)
- A2. Grinding level selector
- A3. Beans container
- A4. Beans container lid
- A5. Accessory door
- A6. Water tank lid
- A7. Water tank
- A8. Power cord
- A9. Steam wand
- A10. Coffee spout
- A11. Hot water spout
- A12. Coffee grinder filter holder bracket
- A13. Coffee grinder outlet
- A14. Small cup drip tray
- A15. Small cup grille
- A16. Cup/mug grille
- A17. Cup/mug grille support
- A18. Drip tray water level indicator
- A19. Drip tray

### 1.2 Description of control panel - B

- B1. Pressure gauge
- B2. "No water" indicator
- B3. "Descal" indicator
- B4. Ground coffee quantity dial
- B5. 1 or 2 cup button (to use the corresponding coffee filter)
- B6. "OK" button: deliver drink/confirm
- B7. "Coffee temperature" button
- B8. Function selector dial
  - Cold Brew
  - Espresso
  - Americano
  - Hot water
  - Descaling
- B9. "Steam" button: to deliver steam

### 1.3 Description of accessories - C

(\* Accessories different for type and number upon model)

- C1. Filter holder
- C2. Dosing and tamping guide
- C3. 1 cup filter
- C4. 2 cup filter
- C5. Tamper
- C6. Milk jug
- C7. "Total Hardness Test" paper
- C8. Descaler (\*certain models only)
- C9. Softballs (\*certain models only)

- C10. Steam wand cleaning needle
- C11. Cleaning brush (\*certain models only)
- C12. Tamping mat (\*certain models only)

### 1.4 Optional cleaning accessories recommended by the manufacturer

For more information, visit [www.delonghi.com](http://www.delonghi.com).

ECO MULTICLEAN  **Cleaner**  
EAN: 8004399333307

## 2. PREPARING THE APPLIANCE

Wash all accessories with warm water and washing-up liquid, then proceed as follows:

1. Insert the drip tray (A19) complete with cup grille (A16) and relative support (A17) (fig. 1);
2. Extract the water tank (A7) (fig. 2) and fill with fresh clean water, taking care not to exceed the MAX level (fig. 3).
3. Put the tank back in the appliance.

**Important:** *Never operate the appliance without water in the tank or without the tank.*

**Please note:** *You should customise water hardness as soon as possible following the instructions in section "9. Settings menu".*

## 3. SETTING UP THE APPLIANCE

1. Plug into the mains socket. Press the main switch (A1) (fig. 4).
2. **Place a container of at least 100 ml capacity under the hot water spout (A11)** (fig. 5).
3. Press the OK button (B6) (fig. 6). Delivery begins and stops automatically. Empty the container.

Before using the coffee maker, the internal circuits of the machine must be rinsed. Proceed as follows:

4. Place the coffee filter (C3) or (C4) in the filter holder (C1).
5. Attach the filter holder (C1) complete with filter to the appliance: to ensure it is attached correctly, align the handle of the filter holder with "INSERT" (fig. 7), then turn the handle to the right until it is aligned in the "CLOSE" position.
6. Place a container under the filter holder and the steam wand (A9).
7. Press the OK button (B6): delivery will begin.
8. When delivery has finished, press the steam button (B9) (fig. 8) and release the jet for a few seconds so as to rinse the steam circuit; to ensure best possible results, this operation should be repeated 3 or 4 times. The purpose of this procedure is to purge any water from the circuit before using steam to prepare a drink.

The appliance is ready for use.

**Please note:** *We also recommend rinsing the internal circuits if the appliance is not used for a long period.*

When using the machine for the first time, 4-5 cups of coffee will need to be made before it gives satisfactory results. Pay particular attention to the quantity of ground coffee in the filter

((C3) or (C4)) (see instructions in section “4.1 Step 1 - Grinding”). Proceed as described in section “The “perfect dose””.

## 4. MAKING COFFEE

### 4.1 Step 1 - Grinding

1. Put coffee beans in the container (A3) (fig. 9). It is best to grind only a quantity of beans sufficient for immediate use, so that the coffee will always be fresh.
2. The default grinding setting is 9 (medium ground). If this is too fine or too coarse, adjust the level according to personal taste and the type of coffee used (adjust only when the coffee grinder is in operation (fig. 10)).

**Please note:** *Adjust the level according to the flow. If the flow is too slow, increase the grinding setting; if it is too fast, reduce it. Selecting levels between 3 and 1 will result in the beans being ground very fine. This kind of setting is suitable only for very special coffee (light roast) or when the quality of the ground coffee is less than ideal, and attributable to worn burrs (grinding too coarse).*

3. Place one of the coffee filters (C3) or (C4) in the filter holder (C1). Press  (B5) to select preparation of 1 or 2 cups. This also doubles the quantity of espresso delivered.
4. Set the quantity by adjusting the dial (B4), starting from the minimum position (fig. 11).

The first time you use it, leave the dial in the Min. position. In the beginning, it is normal to make a few attempts before finding the optimal setting. We suggest you start with the default values, then modify them if necessary following the suggestions in section “Adjusting the quantity of ground coffee in the filter”.

5. Attach the dosing and tamping guide (C2) to the filter holder: 1 press; 2 rotate to lock (fig. 12).
6. Insert the filter holder in the coffee grinder outlet (A13) (fig. 13).
7. Press the filter holder until you hear a “click” (fig. 14), then release. Grinding starts and stops automatically.

**Please note:** *To manually stop grinding, just press the filter holder again (until you hear a click).*

### Adjusting the quantity of ground coffee in the filter

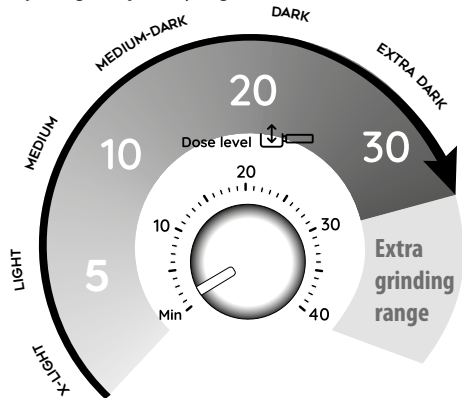

Different varieties of coffee bean give different results when ground: consequently, the initial adjustment of the dosage requires special care.

This illustration shows how to regulate the dosage, based on the roast colour: this should be taken as a general guide, given that in practice, the final adjustment can vary according to the composition of the beans.

1. Set the quantity (to the raised mark inside the coffee filter), starting from the minimum position. The numbers on the dial are a handy reference to note down once the quantity in the filter is ideal. The numbers do not correspond to the coffee grinder settings, measurement units (g/oz) or grinding time.
2. Looking at the roast colour of your particular beans, turn the dial slowly to find the right adjustment.

### 4.2 Step 2 - Tamping

1. After grinding, remove the filter holder (fig. 15).
2. Tap the dosing and tamping guide (C2) to level the ground coffee.
3. (Certain models only): rest the filter holder in the housing on the tamping mat (C12) (fig. 16).
4. Press the coffee using the tamper (C5) (fig. 17).
5. Remove the dosing and tamping guide by turning it anti-clockwise and pulling upwards (fig. 18), and check that the quantity is correct (see “The “perfect dose””).
6. Attach the filter holder to the coffee outlet (A10) (fig. 19).

**Please note:** *Coffee left on the edges of the filter after pressing does not in any way compromise the quality of the brewing and therefore the end result.*

### The “perfect dose”

See next page.

### 4.3 Achieve perfect dose

#### Under dose

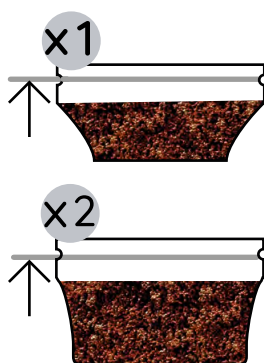

- The coffee ground quantity in the filter is not enough.
- To increase coffee quantity, turn clockwise the coffee dose dial (B4) to increase the number one by one.

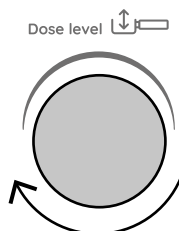

#### ★ PERFECT DOSE

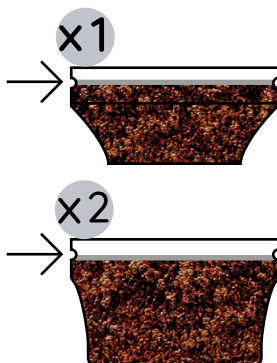

- The filter is filled up to the level of the mark
- The coffee dose dial (B4) is correctly set

#### Over dose

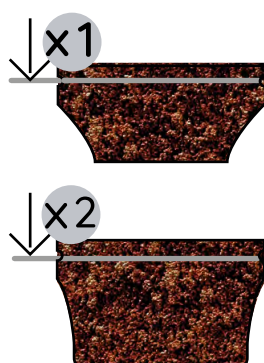

- Too much ground coffee in the filter.
- Next grinding, reduce the coffee quantity by turning anti-clockwise the coffee dose dial (B4) to decrease the number one by one.

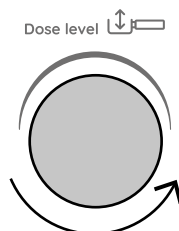

### 4.4 Step 3 - Brewing

1. Select the temperature (fig. 20) (see "Coffee preparation temperature").
2. Select the desired drink (fig. 21). If the drink has been programmed (see section "8. Programming drink quantities"), the drink light blinks briefly.
3. Press OK (B6) to start brewing (fig. 22) (pre-infusion and infusion). Delivery of the coffee will stop automatically.

#### Coffee preparation temperature

The water temperature is controlled during the entire preparation process to ensure its stability during the extraction step. The machine has 3 infusion temperatures\* in a range between 92 and 96 °C.

The temperature effectively utilized will depend typically on the variety of bean and the roast: Robusta beans require a lower temperature, and Arabica beans a higher temperature. The same applies for dark roasted beans or for light roasted beans, respectively.

Temperature level	Corresponding indicator light	Roast colour
<b>MIN</b>		<b>Dark</b>
<b>MED</b>		<b>Medium-dark</b>
<b>MAX</b>		<b>Light - medium</b>

\* This is the temperature of the water in the thermoblock. It is therefore different to the temperature of the drink in the cup or the temperature of the drink at the moment of release from the outlets of the filter holder.

## 5. ACHIEVE ESPRESSO PERFECTION

Extracting the perfect espresso is an art and might take a couple of tries. Be ready to adjust the coarseness of the grind and always make sure to have the tamped ground coffee at the indicator line in the filter (perfect dose) to be able to reach perfect extraction.

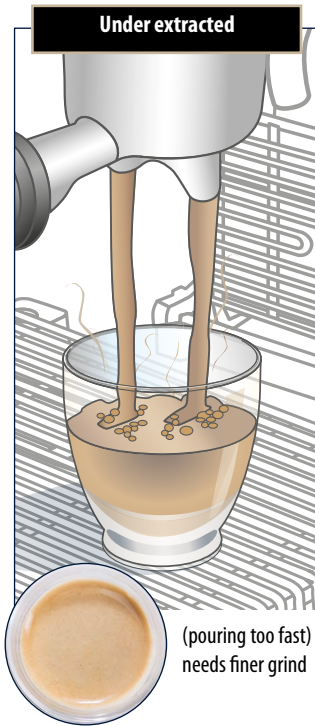

(pouring too fast)  
needs finer grind

- Flowing fast like water
- Light and pale Crema

### To make it perfect:

- Adjust grinding setting to a finer setting 1 step at a time.

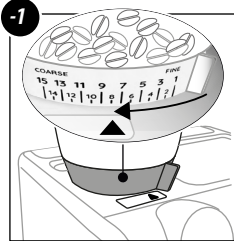

- Make sure ground coffee quantity reaches the “perfect dose”: if not, adjust the coffee dose dial (B4) (see “4.3 Achieve perfect dose”).

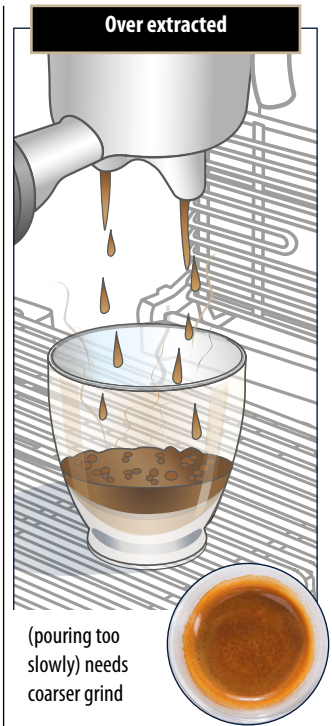
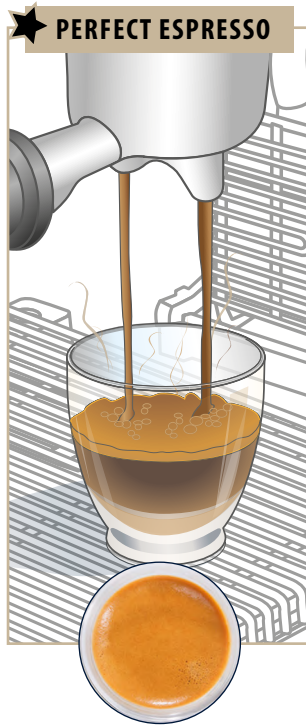

(pouring too slowly)  
needs coarser grind

- Flowing in drips or not at all
- Crema very dark and not uniformed

### To make it perfect:

- Adjust grinding setting to a coarser setting 1 step at a time.

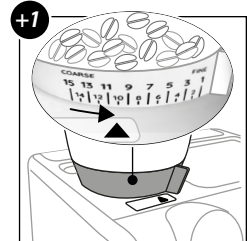

- Make sure ground coffee quantity reaches the “perfect dose”: if not, adjust the coffee dose dial (B4) (see “4.3 Achieve perfect dose”).

## 6. PREPARATION OF COLD BREW BEVERAGES



Cold Extraction Technology provides a method of preparing coffee that uses cold water, or water at room temperature. Instead of heat, a longer period of infusion is used to extract the properties of the coffee beans.

Proceed as follows:

1. Select Cold Brew  (fig. 23). The indicator light of the OK button turns blue.
2. To ensure the coffee circuit is cold, it will be advisable to run a trial delivery first: accordingly, place a container under the coffee spout (A10) and press OK: press OK again after a few seconds to stop the delivery;
3. Remove and empty the container, then attach the filter holder, with the appropriate dose, to the coffee spout;
4. Prepare a glass with 2-3 ice-cubes and position it under the coffee spouts (fig. 24);
5. Press OK (indicator light blue): delivery will begin.
6. Delivery stops automatically.

**Please note:**

- Cold Extraction is a pressureless technology: consequently, the pressure gauge does not move during delivery.
- Make certain that the water in the tank is fresh. If the water is one or two days old, empty the tank and rinse thoroughly. Keep the water tank clean at all times.

## 7. MAKING MILK DRINKS

### 7.1 Frothing the milk

1. Fill the jug (C6) with the amount of milk to be warmed/ frothed, bearing in mind that the volume of the milk will increase 2- or 3-fold (fig. 25). For a denser and more evenly distributed froth, best results will be achieved using whole cow's milk at refrigerator temperature (about 5 °C).

## My Latte Art

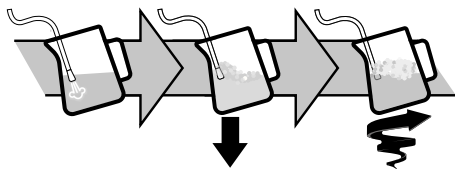

2. Place the jug under the steam wand and press the steam button (B9) (fig. 26).
3. To froth the milk, rest the steam wand (A9) on the surface of the liquid. This mixes air with the milk and steam.

4. Keep the steam wand in contact with the surface, taking care not to let in too much air and create excessively large bubbles.
5. Immerse the steam wand below the surface of the milk, this creates a vortex in the liquid. Once the milk is heated to the desired temperature, press the steam button again and wait for the flow of steam to stop completely before removing the milk carafe from the machine.

**Barista tips:**

- **Fresh milk is best.** Always use fresh milk straight from the fridge.
- For best results, always replace the milk carafe in the fridge when not in use.
- Whole milk ensures optimum results. The appearance and texture of froth depending on the nature of the dairy milk or vegetable drinks utilized.
- After frothing the milk, eliminate unwanted bubbles by swirling the jug gently.

### Cleaning the steam wand







1. Following use, always wipe the steam wand (fig. 27) with a cloth to remove residual deposits of milk. The recommended procedure for in-depth cleaning is to use Eco MultiClean: this product ensures maximum hygiene by removing milk proteins and fats, and can be used for cleaning the entire machine.
2. Release steam for a few seconds to clean the wand (fig. 8).
3. Wait until the steam wand has cooled down. To ensure the wand works efficiently over time, use the special cleaning tool (C10) to free the holes (fig. 28) of any obstruction.

## 8. PROGRAMMING DRINK QUANTITIES



1. Prepare the appliance to deliver 1 or 2 cups of the drink you want to make, as far as attaching the filter holder (C1) complete with the (C3) or (C4) filter and ground coffee.
2. Turn the dial (B8) to select the drink being programmed.
3. Press the OK button (B6) and hold for a least 3 seconds, until the indicator relative to the selected drink starts to blink, indicating that the machine is in programming mode.
4. When the desired quantity has been reached, press the OK button again: the quantity is programmed.







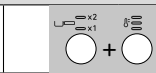
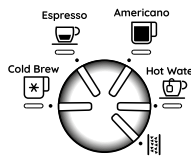







**Please note:**

- You can programme drinks, but not steam delivery.
- Programming changes the quantity of drink delivered, but not the quantity of ground coffee
- When a programmed drink is selected, the corresponding light blinks briefly.
- "2x" drinks can be programmed separately.

Coffee recipe	Default quantity	Programmable quantity
Cold Brew 	≈ 110 ml	≈ 90 to ≈130 ml
Cold Brew  2x	≈ 180 ml	≈ 160 to ≈ 220 ml
Espresso 	≈ 35 ml	≈15 to ≈90 ml
Espresso  2x	≈ 70 ml	≈30 to ≈180 ml
Americano 	≈ 120 ml	<ul style="list-style-type: none"> <li>• espresso: ≈20 to ≈90 ml</li> <li>• water: ≈25 to ≈150 ml</li> </ul>
Americano  2x	≈ 240 ml	<ul style="list-style-type: none"> <li>• espresso: ≈30 to ≈180 ml</li> <li>• water: ≈50 to ≈240 ml</li> </ul>
Hot water 	≈ 250 ml	from ≈65 to ≈300ml

## 9. SETTINGS MENU

1. Access the menu:			
Press together and hold for 3 seconds			
2. Select the setting to be adjusted			
			
Corresponding setting	Turn to	Press	Press again to change the setting
Statistics (info useful for assistance purposes)			See section "16.1 Statistics"
→			

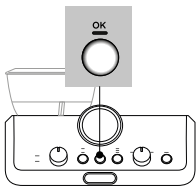
Pre-infusion pause		The indicator light corresponding to the setting currently selected comes on	 → No
			 → 1 sec
			 → 2 sec
Extra grinding adjustment		The indicator light corresponding to the setting currently selected comes on	 → 1 <sup>st</sup> range
			 → 2 <sup>nd</sup> range
Auto-off		The indicator light corresponding to the setting currently selected comes on	 → 9 minutes
			 → 1.5 hours
			 → 3 hours
Water hardness		The indicator light corresponding to the setting currently selected comes on	 → soft
			 → medium
			 → water /very hard
3. Save the new settings by pressing OK (B6)			
			

**Please note:** The appliance exits the settings menu automatically if there is no activity for 30 seconds.

### 9.1 Reset default settings

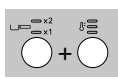
1. Access the menu:	
Press together and hold for 3 seconds	
2. Reset to default values	

Press and hold the steam button (B9) for 3 seconds.



The OK light (B6) blinks briefly to confirm the reset.

**10. CLEANING THE APPLIANCE**

**Important!**

- Do not use solvents, abrasive detergents or alcohol to clean the coffee machine.
- Do not use metal objects to remove encrustations or coffee deposits as they could scratch metal or plastic surfaces.
- Should the machine remain idle for more than a week, it is advisable to carry out a rinse cycle before preparing any drinks.

**Danger!**

- Never immerse the coffee maker in water when cleaning: it is an electrical appliance.
- Before commencing any cleaning operation on the outside of the machine, turn it off, unplug it from the mains socket and wait for it to cool down.

	✗	✓	✓	✗	✗
	✓	✗	✗	✓	✓
	✗	✓	✓	✓	✓
	✗	✗	✗	✓	✓
	✗	✗	✓	✗	✗
	✗	✗	✗	✓	✓

**11. CLEANING THE COFFEE GRINDER**

1. Clean the attachment area with the brush (C11) (fig. 29).
2. Use the brush to clean the coffee guide (fig. 30).

**Efficient grinding**

The burrs are subject to wear over time. As time goes by, to achieve the perfect quantity, you need to turn the dial (B4) towards the highest numbers. When you reach a setting of between 30 and 40, you need to set the extra grinding range (see section "9. Settings menu" - "Extra grinding range").

When the quantity of ground coffee becomes less than expected, contact a service centre to have the burrs replaced. With the new burrs fitted, adjust the coffee grinder by accessing the settings menu and selecting the first range of the "extra grinding adjustment" setting. Next, turn the ground coffee quantity dial (B4) to the Min position and set the quantity as for first-time use (see "The "perfect dose"").

**12. WATER HARDNESS**

The descale indicator (B3) lights up following a predetermined period of operation that depends on the hardness of the water. The machine can also be programmed according to the actual hardness of the local water supply, in which case descaling may be required less frequently (see section "9. Settings menu").

1. Remove the "TOTAL HARDNESS TEST" indicator strip (C7) from its pack.
2. Immerse the strip completely in a glass of water for about one second (fig. 31).
3. Remove the strip from the water and shake lightly (fig. 32).

Water Hardness Test Result	(B7) button	Level
		<b>1</b> soft water
		<b>2</b> medium water
		<b>3</b> hard or very hard water

4. Set the machine accordingly, as indicated in the section "9. Settings menu".

**13. HOW TO USE SOFTBALLS (CERTAIN MODELS ONLY)**

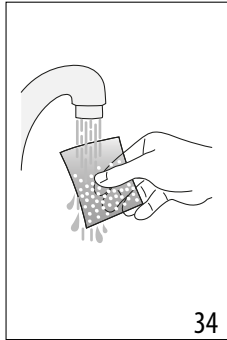
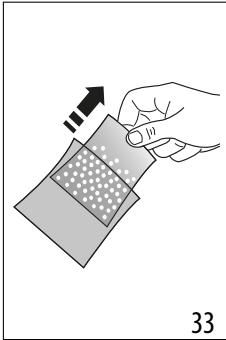

Softballs (C9) are an innovative treatment system able to prolong the life of the machine, without altering the properties of the water, while ensuring consistently creamy and aromatic coffee. To optimize the effectiveness of the treatment, leave Softballs in water overnight before use.

1. Take the sachet of Softballs from the wrapper (fig. 33).



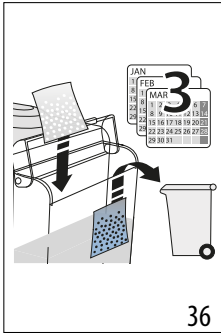
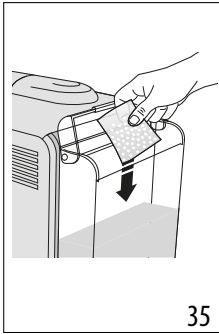

2. Rinse the sachet of Softballs under running water (fig. 34).
3. Immerse the sachet in the water tank (A7) (fig. 35).
4. Change the sachet of Softballs every 3 months (fig. 36).

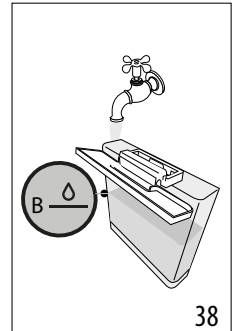
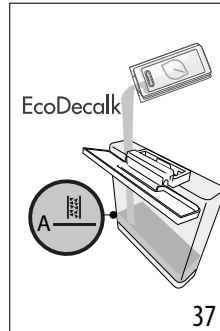

3. Empty the water tank (A7). (If present, remove the softballs and place in a glass of water until they can be re-inserted at the end of the descaling process.)
4. Pour the descaler into the water tank (C8) up to the level A  marked on the inside of the tank (corresponding to the contents of one 100ml pack) (fig. 37).
5. Add water (1 litre) up to level B  (fig. 38). Now reposition the water tank in the machine.



6. Turn the knob (B8) to  (fig. 39): the OK indicator lights up and the  indicator blinks.

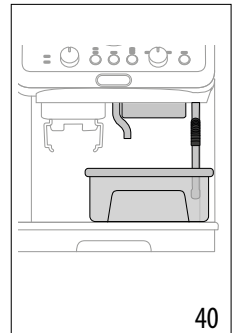
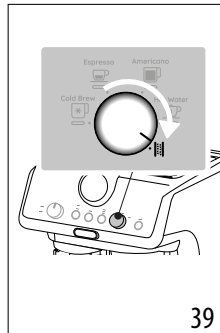

## 14. DESCALING

### Important!

- Before using the descaler, (C8) read the instructions and the labelling on the pack.
- Use De'Longhi descaler only. Using unsuitable descaler and/or performing descaling incorrectly may result in faults not covered by the manufacturer's guarantee.
- Descaler can cause damage to delicate surfaces. If the product is accidentally spilt, dry immediately.

To descale	
Descaler	De'Longhi descaler
Container	Capacity 2 litres
Time	~20min

1. When the indicator light  (B3) comes on, you need to descale the appliance. You can start descaling at any time.
2. Remove and empty the drip tray (A19), then reposition it in the machine.

7. Make sure the filter holder (C1) is not attached. Position a container under the coffee spouts (A10) and hot water spout (A11) and another under the steam wand (A9) (fig. 40).
8. Press the hold the OK button (B6) for at least 3 seconds. The OK light blinks.
9. The descaling programme starts and the descaler liquid comes out of the spouts. The descale programme removes limescale deposits from inside the appliance by automatically performing a series of rinses and pauses until the tank is empty.

Descaling ceases and the OK light turns blue. This means that a rinse cycle must be carried out:



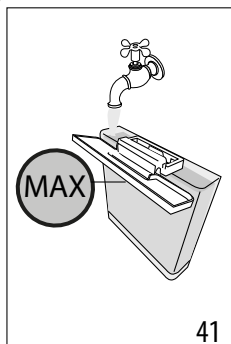







10. Empty the containers used to collect the descaler solution and reposition them under the spouts.
11. Remove the water tank, empty out any residual descaler solution, rinse under running water and fill with fresh water up to the MAX level (fig. 41). Put the tank back in its housing.
12. Press the OK button: the rinse cycle will start.
13. When rinsing is complete, delivery stops: the  indicator blinks and the OK indicator extinguishes.
14. Empty the recipient used to collect the rinse water.
15. Remove and empty the drip tray (A19), then reposition it in the machine.
16. Remove the tank, fill with fresh water and reposition in the machine. (If present, rinse the softballs with running water and put back in the tank).
17. Turn the function selection dial (B8) to one of the drinks. The machine is now ready for use.









**Please note:**

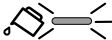

- The descaling cycle can be started up at any time (even if the relative light has not yet come on).
- Should descaling be started up by mistake, it can be stopped by pressing the OK button and holding for 10 seconds; the rinse cycle cannot be stopped.

## 15. EXPLANATION OF INDICATOR LIGHTS

LIGHTS	EXPLANATION OF INDICATOR LIGHTS	OPERATION
All lights blink briefly	Turning the appliance on	Self-diagnosis
 <b>Permanently alight</b>	The machine has been turned on for the first time and the water circuit must be filled	Proceed as indicated in section "3. Setting up the appliance"
 <b>Blinking</b>	The machine is warming up	Wait until the ideal delivery temperature has been reached
 <b>Permanently alight</b>  (The indicators  and  show the respective selections)	The machine is ready for delivery	Set up the machine and proceed with preparation of the drink
 <b>Permanently alight</b>  (The  indicator shows the selection in progress)	The machine is ready for delivery	Set up the machine and proceed with preparation of the drink
 <b>Permanently alight</b>	There is not enough water in the tank (A7) or the tank is not correctly in place	Fill the tank with water, or remove the tank and reposition it correctly

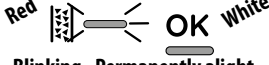
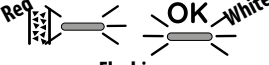

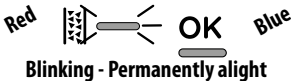
LIGHTS	EXPLANATION OF INDICATOR LIGHTS	OPERATION
 <p><b>Blinking</b></p>	An attempt is being made to deliver a beverage, but with water tank (A7) empty	Fill the tank with water
	Because the beans are too finely ground, the coffee is delivered too slowly or not at all	Remove the filter holder (C1) and repeat the coffee-making steps, bearing in mind the indications given in sections "4.1 Step 1 - Grinding" and "4.2 Step 2 - Tamping"
	The coffee filter (C3) or (C4) is obstructed	Rinse the filters under running water
	The tank (A7) is not properly in place and the relative valves are not open	Press down lightly on the tank to open the valves
	Limescale in the water circuit	Descal as described in section "14. Descaling"
 <p><b>x2</b> <b>x1 Permanently alight</b></p>	1 cup preparation is selected	The entire preparation procedure (from grinding to delivery) is set to make 1 cup
 <p><b>x2 Permanently alight</b> <b>x1</b></p>	2 cup preparation is selected	The entire preparation procedure (from grinding to delivery) is set to make 2 cups
 <p><b>MIN MED MAX</b> <b>Permanently alight</b></p>	Select one of the available temperatures	See "Coffee preparation temperature"
 <p><b>Blinking</b></p>	General alarm	Turn the machine off and wait 10 minutes before turning on again. If the problem continues, contact customer services.
 <p><b>Blinking</b></p>	The steam function is selected and in use	After a few seconds, the machine starts delivering steam
 <p><b>Permanently alight - red</b></p>	Descaling is required	Carry out descaling as described in section "14. Descaling"
 <p><b>Red</b> <b>OK</b> <b>White</b> <b>Blinking - Permanently alight</b></p>	Descaling is selected	Press OK to start descaling or turn the dial to a drink
 <p><b>Red</b> <b>OK</b> <b>White</b> <b>Flashing</b></p>	Descaling proceeds. The machine delivers descaling solution	Proceed by completing the descaling cycle (see "14. Descaling")
→		

LIGHTS	EXPLANATION OF INDICATOR LIGHTS	OPERATION
 <p><b>Blinking - Permanently alight</b></p>	The first step of the descaling cycle is complete: the next step required is a rinse.	Press OK to start rinsing.
 <p><b>Flashing</b></p>	The machine proceeds with the rinse to complete the descaling process	Proceed by completing the descaling cycle (see "14. Descaling")

## 16. TROUBLESHOOTING





PROBLEM	CAUSE	SOLUTION
There is water in the drip tray (A19)	This water comes from the internal circuits of the machine and is a normal consequence of their operation	Empty and clean the drip tray on a regular basis
The machine fails to produce espresso coffee	No water in the tank (A7)	Fill the tank
	The <b>OK</b> indicator (B6) is alight, meaning that the coffee circuit or the steam circuit is empty	Press the button associated with the <b>OK</b> indicator to fill the circuit
	Blockage in the coffee filter (C3) or (C4)	Rinse the filters under running water
	Coffee ground too finely	Adjust the quantity and grinding level
	The tank (A7) is not properly in place and the valves at the bottom are not open	Press down lightly on the tank to open the valves at the bottom
The filter holder (C1) cannot be attached to the appliance	Limescale in the water circuit	Descale as described in section "14. Descaling"
	The ground coffee has not been tamped or the quantity is excessive	Repeat phase 1 (section "4. Making coffee") using less coffee. If you are using the 1 cup filter, make sure the 1X light (B5) is on.
The espresso coffee drips from the edges of the filter holder (C1) instead of from the holes	The filter holder is not correctly in place	Attach the filter holder correctly (fig. 19)
	The coffee spout gasket has lost flexibility or is dirty	Contact a customer services centre to have it replaced
	Blockage in the coffee filter (C3) or (C4)	<ul style="list-style-type: none"> <li>• Rinse the filters under running water</li> <li>• Adjust the grinding settings</li> </ul>
The espresso cream is too light (delivered from the spout too fast)	The machine settings need to be reappraised	See instructions in section "The "perfect dose""
The espresso cream is too dark (delivered from the spout too slowly)	The machine settings need to be reappraised	See instructions in section "The "perfect dose""
The coffee is cold	A Cold Brew drink has been made	When the OK indicator is blue, Cold Brew Technology is selected
→		



<b>PROBLEM</b>	<b>CAUSE</b>	<b>SOLUTION</b>
The Cold Brew drink is warm	A hot drink was delivered shortly before the Cold Brew	Before preparing the beverage, it is advisable to cool the coffee circuit by running a trial Cold Brew delivery for a few seconds
	There water in the tank is not fresh	Empty the water tank, rinse and fill with fresh water
	No ice in the glass	Put 3-4 ice-cubes in the glass as described for the preparation of Cold Brew drinks
On completion of the descale cycle, the machine calls for a further rinse	During the rinse cycle, the water tank (A7) has not been filled to the MAX level	Repeat the rinse cycle (see section "14. Descaling")
The machine does not grind the coffee	Foreign matter has found its way into the coffee grinder	Turn the selector (A2) to 8 and remove all beans with a vacuum cleaner until the beans container (A3) is empty and clean. If the problem continues, contact customer services
Changing to a different type of coffee		<ul style="list-style-type: none"> <li>You are recommended to pour only the amount of beans to be used into the beans container (A3)</li> <li>To empty the container, vacuum out the contents with a vacuum cleaner or grind all the beans in the container until completely empty.</li> <li>Add new type of coffee beans</li> <li>If the amount of ground coffee does not give the perfect dose, proceed to set up the machine as for first-time use</li> </ul>
After grinding, the coffee filter (C3) or (C4) is empty	The funnel of the coffee grinder is clogged	Clean as described in section "11. Cleaning the coffee grinder".
After grinding, the amount of coffee in the filter (C3) or (C4) does not give the "perfect dose"	The quantity of ground coffee needs adjusting	Adjust the quantity with the relative dial (B4), following the indications given in section "The "perfect dose"". If the dial is already in the max. position, proceed as described in section "9. Settings menu" - "Extra grinding adjustment"
	You are using the 2 cup filter (C4)	Make sure the 2X light is on
	Over time the burrs wear down	Contact Customer Services



## 16.1 Statistics

Machine statistics are useful in the event of service being needed. Proceed as follows:

- Access the menu by pressing buttons (B5) and (B7) simultaneously and holding for 3 seconds;
- Turn the dial (B8) to select “Cold Brew”;
- Press the temperature button (B7);
- Once inside the settings menu, bring up the required statistical information by positioning the selector dial as illustrated in the following table:

Positioning of dial	Counter
	Total count of cold drinks
	Total count of hot drinks
	Total count of steam deliveries
	Total count of descale cycles

- The numbers are shown alongside the relative indicators , , :

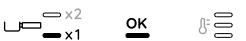
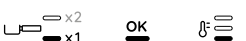
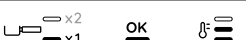
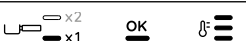
Control panel indicators	Drinks count	Descale count
	up to 100	up to 1
	between 100 and 1000	between 2 and 10
	between 1000 and 3000	between 10 and 30
	between 3000 and 6000	between 30 and 60
	between 6000 and 11000	between 60 and 110
	more than 11000	more than 110

- The machine comes out of the settings menu automatically if 30 seconds elapse without any activity.

**Register Now**   
[www.delonghi.com/register](http://www.delonghi.com/register)

